



Posidyne 1.5 Specifications

Size	Logic	Max Clutch Torque (Lb. In.)			Max. Brake Torque (Lb. In.)					Max. RPM	Max. KE per Engmt. (Ft. Lbs.)	Average Thermal HP		Air Vol. per Engmt. (in ³)	Oil Cap (Qts)		Inertia of Cyclic Parts (Lb.Ft ²)
					Springs Only		With Max. Air Assist					Cooling			Horz.	Vert.	
		Static	Dyn.	Max. Air Press (psi)	Static	Dyn.	Static	Dyn.	Max. Air Press (psi)			Basic	Fan				
1.5	S	427	367	60	32	27	484	416	60	3600	11,230	Horiz.		.50	2.0	2.5	.012
	SA	387	333	70	110	95	492	423	70			.25	.55				
	A	387	333	70	110	95	—	—	—			Vert.					
	B	240	206	70	220	189	—	—	—								
	C	427	367	60	—	—	—	—	—								
	P	464	399	70	—	—	464	399	70								

NOTES:

Thermal Horsepower ratings based on 1800 RPM, 80° F ambient, 220° F max. oil temperature.
 Air pressures are at maximum. Actual operating pressures will typically run much lower. See Pressure VS Static Torque Charts

Posidyne 1.5 Overhung Load Capacity (Lbs. Pull) at midpoint of shaft extension

Size	Input Shaft				Output Shaft							
	300 RPM	1200 RPM	1800 RPM	3600 RPM	900 RPM		1200 RPM		1800 RPM		3600 RPM	
					Without Encoder	With Encoder	Without Encoder	With Encoder	Without Encoder	With Encoder	Without Encoder	With Encoder
1.5	275	175	150	120	360	245	360	245	335	235	265	186

Posidyne 1.5 Dimensions—Input Module

INPUT MODULE #1

7/8" Dia. male extended input shaft and foot mounting

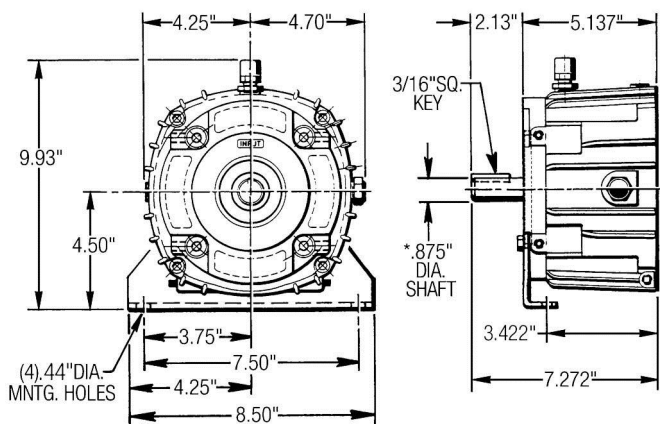

INPUT MODULE #1 with fan cooling

7/8" Dia. male extended input shaft and foot mounting

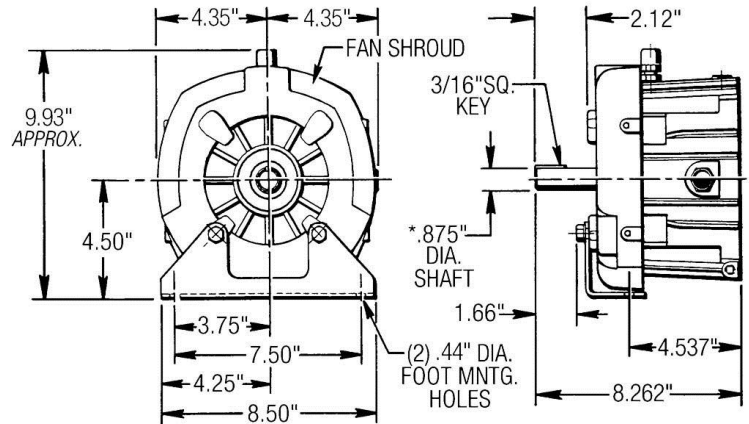



Posidyne 1.5 Dimensions—Input Module

INPUT MODULE #2 & #3 (C Face)
 5/8" or 7/8" Dia. FU, 4.50" AK, Split Clamped Quill
 (56/143TC or 145TC frame)

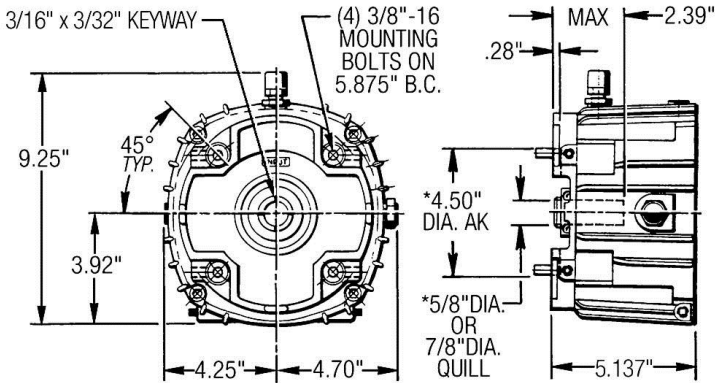

INPUT MODULE #4 (C Face)
 1 1/8" Dia. FU, 8.50" AK, Split Clamped Quill
 (182TC/184TC frame)

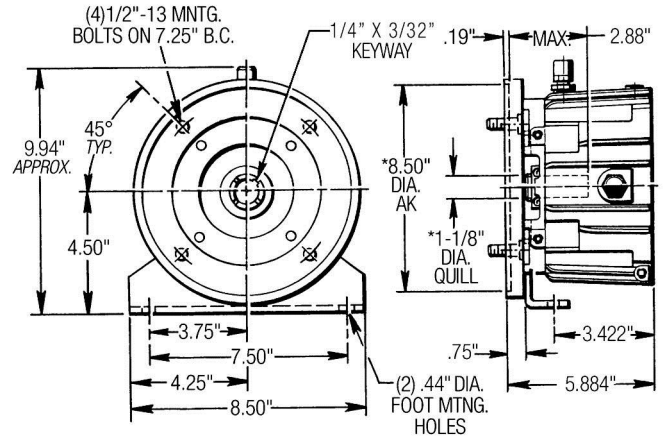

INPUT MODULE "A" & "B" (C Face)
 5/8" or 7/8" Dia. FU, 4.50" AK, Split Clamped Quill & foot mounted
 (56/143TC or 145TC frame)

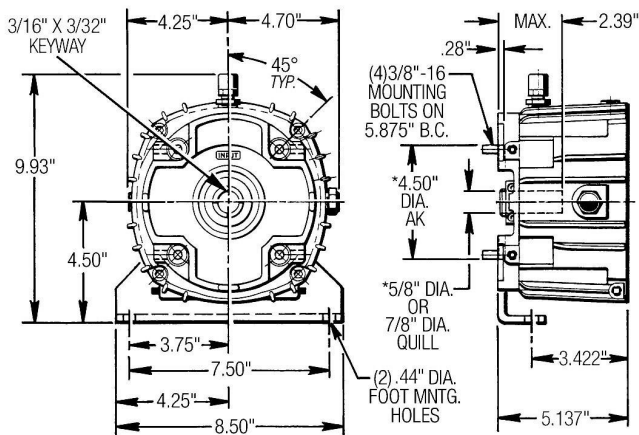

INPUT MODULE "C" (C Face)
 1 1/8" Dia. FU, 8.50" AK, Split Clamped Quill & foot mounted
 (182TC/184TC frame)

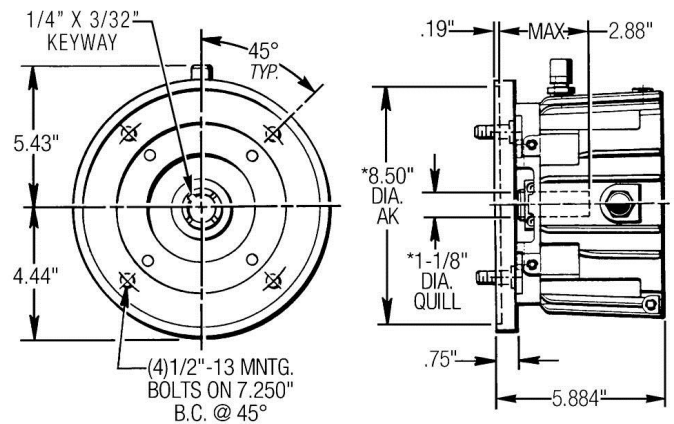



Force Control Industries, Inc.
 3660 Dixie Highway Fairfield, Ohio 45014 USA
 Phone: 513-868-0900 Fax: 513-868-2105

OUTPUT MODULE #1
 7/8" Dia. Output shaft and foot mounting

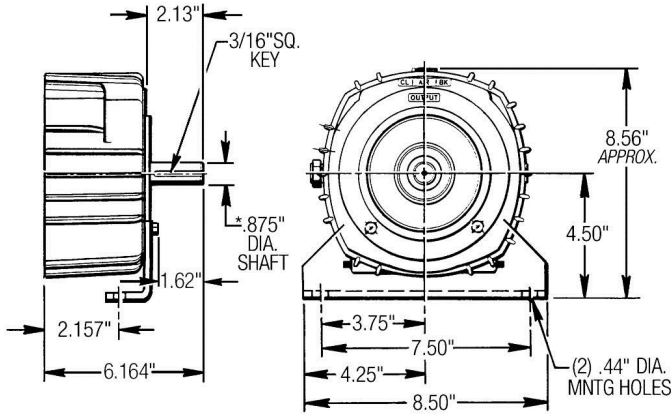

OUTPUT MODULE #2 & #3 (C Face)
 5/8" or 7/8" Dia. FU, 4.50" AK, with Manifold Mounted Valve
 (56/143TC or 145TC frame)

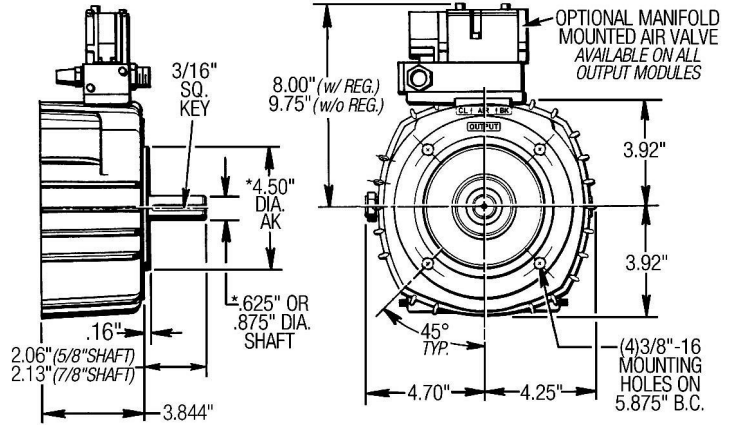

OUTPUT MODULE "4" (C Face)
 1 1/8" Dia. FU, 8.50" AK, (182TC/184TC frame)

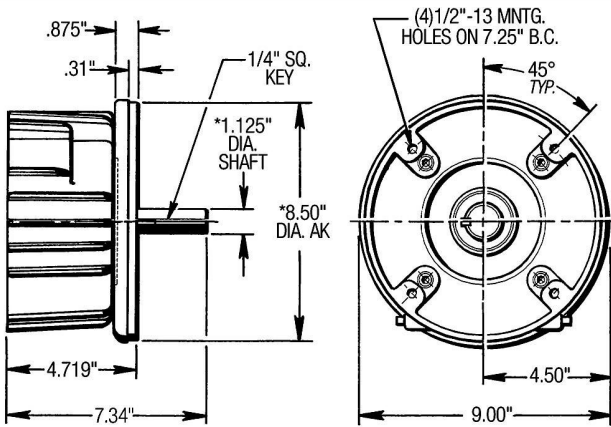

OUTPUT MODULE "D"
 7/8" Dia. Output shaft, foot mtd. & Optical Encoder

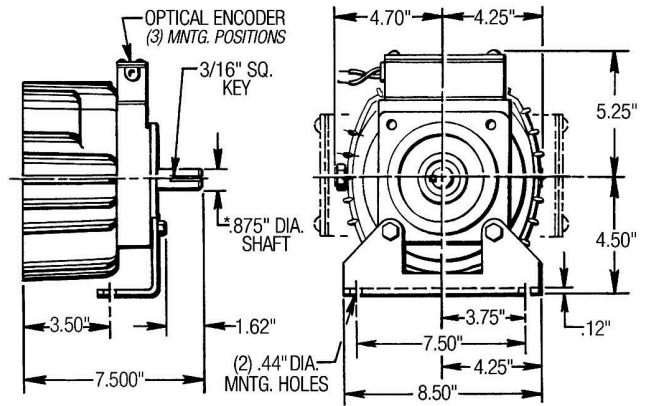

OUTPUT MODULE "A" & "C" (C Face)
 5/8" or 7/8" Dia. FU, 4.50" AK, with Optical Encoder
 (56/143TC or 145TC frame)

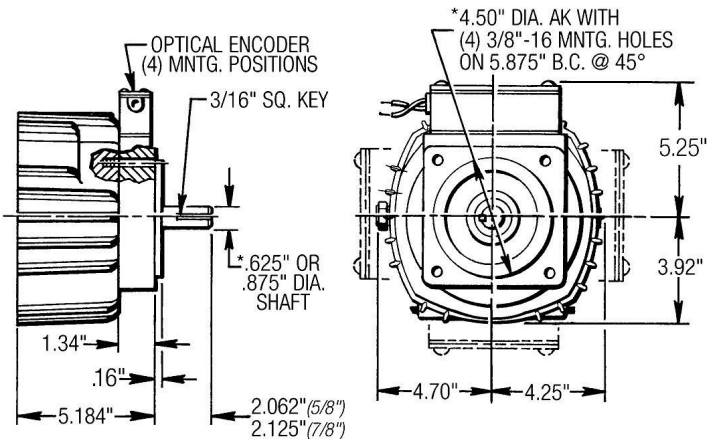

OUTPUT MODULE "E" (C Face)
 1 1/8" Dia. FU, 8.50" AK, & Optical Encoder
 (182TC/184TC frame)

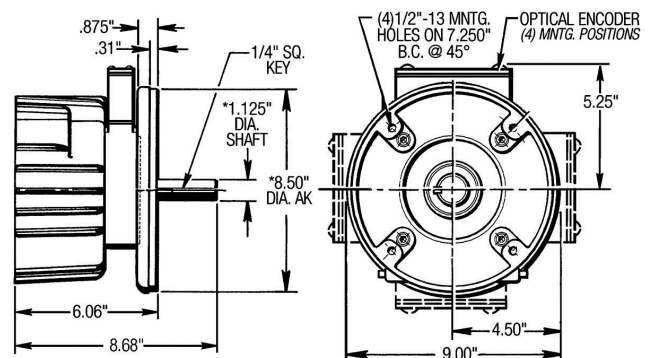



Posidyne 1.5—How To Order

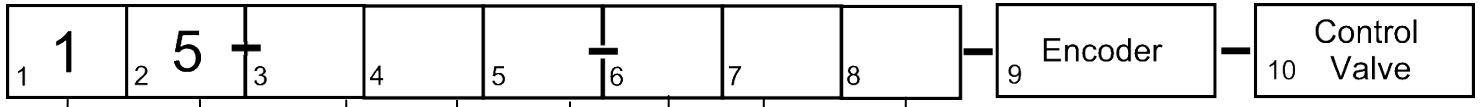

(1, 2) Size

1	5	=02
---	---	-----

(3) Input Module

1	= 7/8" FU extended shaft (with mounting feet)		
2	= 4 1/2 FAK, 5/8" FU	56C	C-Face Quill
3	= 4 1/2 FAK, 7/8" FU	143TC	
		145TC	
4	= 8 1/2 FAK, 1 1/8" FU	182TC	
		184TC	
A	= 4 1/2 FAK, 5/8" FU, with clamped split quill input shaft and Foot Mounting (56C frame)	56C	C-Face Coupled
B	= 4 1/2 FAK, 7/8" FU, with clamped split quill input shaft and Foot Mounting	143TC	
		145TC	
C	= 8 1/2 FAK, 1 1/8" FU, with clamped split quill input shaft and Foot Mounting	182TC	
		184TC	

(4) Control Logic

S	= S - Air set clutch / light spring set brake with Air assist
A	= A - Air set clutch / medium spring set
B	= B - Air set clutch / heavy spring set
C	= C - Air set clutch / no brake
D	= SA - Air set clutch / medium spring
P	= P - Air set clutch / Air set brake (without springs)

(5) Output Module

1	= 7/8" U extended shaft (with mounting feet)		
2	= 4 1/2 FAK, 5/8" FU	56C	C-Face Quill
3	= 4 1/2 FAK, 7/8" FU	143TC	
		145TC	
4	= 8 1/2 FAK, 1 1/8" FU	182TC	
		184TC	
A	= 4 1/2" AK, 5/8" U, with Optical Encoder*	56C	
C	= 4 1/2" AK, 7/8" U, with Optical Encoder *		
D	= Optical Encoder 7/8" U, Foot Mounting*		
E	= Optical Encoder 8 1/2" AK, 1 1/8" U *		

(6) Mounting Position

H	= Horizontal
D	= Vertical, Input Down
U	= Vertical, Input Up
L	= Wall on Left (Viewing Input)
R	= Wall on Right (Viewing Input)
Z	= Horizontal, Marine Duty
W	= Vertical, Input Down, Marine Duty
P	= Vertical, Input Up, Marine Duty

N=No Encoder.
 See How to Order Encoder for Ordering Number.

N=No Valve
 See How to Order Valve for Ordering Number

(8) Valve Porting Location

T	= Top	B	= Bottom
R	= Right	L	= Left

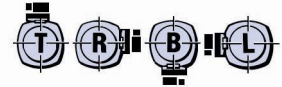

Assembly Options

Location	Std.	C Face	Foot Mtd.
T	X	X	X
R	X	X	X
B	X	X	---
L	X	X	X

Viewing Input Shaft

(7) Cooling

1	= Basic (Radiant)
5	= Fan Cooled***
6	= Basic (Manifold Mtd. Valve)
7	= Fan Cooled (Manifold Mtd. Valve)

NOTES

* The Output Housing is machined to accept an encoder.

Example

To order a size 1.5 Posidyne, C Face input for 184TC frame motor, with "S" Control Logic, output housing to accept encoder, horizontal mounting, basic cooling, with manifold mounted control valve on top.

Ordering Number 15-4SC-H-1-T/___/___