

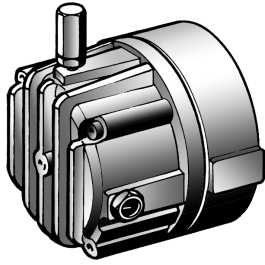

MB-056 Posistop Motor Brake INSTALLATION MANUAL



DESCRIPTION

Posistop Motor Brakes are multiple surface, spring activated, pneumatic release braking devices that effectively dissipate the heat generated from electric motors that require frequent starting and stopping.

FORCE CONTROL provides 8 Models of **Posistop Motor Brakes** to meet your individual requirements for deceleration torque, thermal dissipation and static torque.

This manual covers the smallest size or Model MB-056. For information on other sizes and models not covered in this manual, contact the Force Control factory or your Force Control representative.

OPERATION

The **Posistop Motor Brake** Cross Section shown in *Figure 1* shows the brake in the normally spring loaded braking position.

Compressed air, controlled by external valving, enters the piston chamber and moves the piston to disengage the Multiple

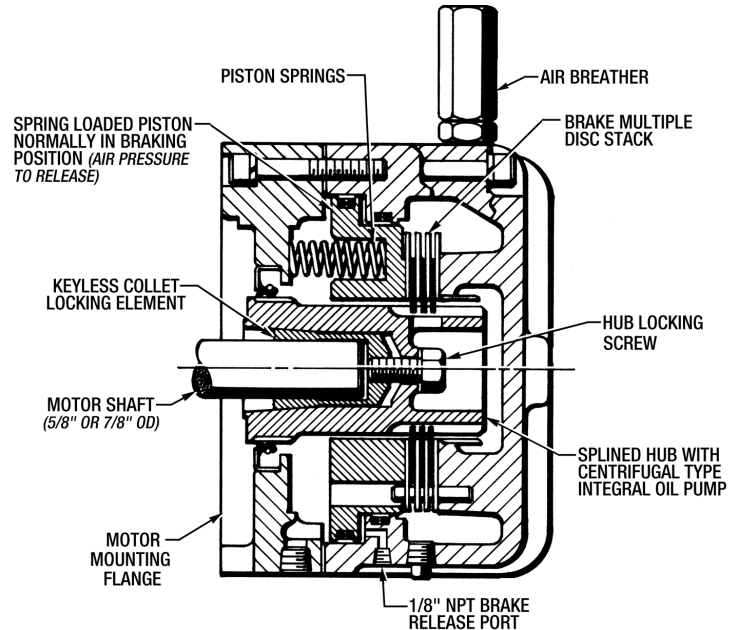

Figure 1 - Unit Description and Operation

Braking Disc Stack, allowing the drive motor to rotate freely. When the air pressure is released the piston, which is spring loaded, returns to the normal braking position.

INSTALLATION

IMPORTANT SAFETY PRECAUTIONS

The Brake Unit described in this manual must not be installed in any manner except as specified and must not be operated at speeds, torque loads or temperatures other than those specified. Failure to limit operation of the brake to the conditions specified could damage the unit and may cause malfunction or damage to interconnecting equipment.

WARNING - The following precautions must be taken if the installation of the Posistop Motor Brake is to be a retrofit for an existing application. Before attempting installation, open the motor disconnect, shut off the control electrical supply and lock them out to avoid any possibility of personal injury. Be sure any mechanisms holding inclined or vertical loads are locked mechanically with cribbing or other means.

A. VERIFYING MOTOR SPECIFICATIONS

The Motor Manufacturer's Specifications must be verified first to ensure the Motor Brake Oil Seal Reliability. The Motor Shaft Runout, Mounting Face Runout and the Motor Shaft to Pilot Diameter Eccentricity need to be checked with a Dial Indicator as shown in *Figure 2*.

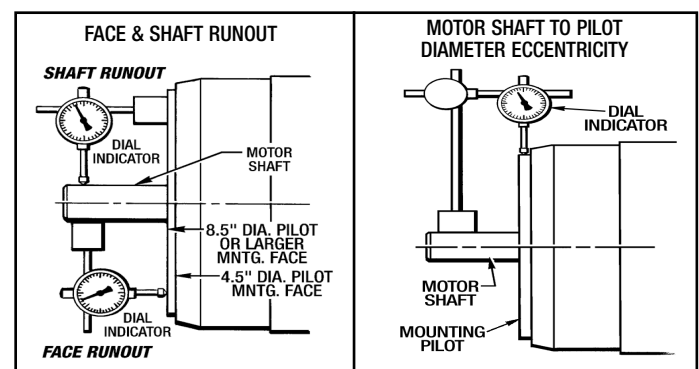

Figure 2 - Verifying Motor Specifications

The **Posistop Motor Brake** has been pre-assembled at the factory for ease of shipment and installation.

Force Control Industries, Inc.

MAXIMUM ALLOWABLE T.I.R. (Inches)

(As Per NEMA MG 1 Standard)

Pilot Dia. Dimension	Tolerance On Pilot Dia.		Maximum Allowable Shaft Runout	Maximum Allowable Face Runout	Maximum Allowable Eccentricity
	Plus	Minus			
Less than 12"	.000"	.003"	.002"	.004"	.004"

CAUTION - T.I.R. in excess of this maximum will result in a potential leak condition.

B. HUB ASSEMBLY TO MOTOR SHAFT

1. First check motor shaft for any nicks or burrs. Clean up and deburr if necessary.
2. Apply a light coating of Vaseline or equivalent to the Wear Sleeve (#86) which is located on the Hub (#2). This will facilitate sliding the Housing (#8) over the Hub (#2) at a later point.

IMPORTANT: Do not lubricate the hub bore or the motor shaft.

3. Insert the Collet (#110) into the Hub (#2) until it is seated. Assemble the Screw (#94) and Copper Gasket (#30) into the Hub and Collet. Do not tighten at this time.
4. Slide the Hub Assembly onto the Motor Shaft.

C. HUB ALIGNMENT

1. Holding a straight edge across the face of the Hub, measure from the straight edge to the motor mounting face. It should measure 5/16" Adjust if necessary. (See Figure 3)

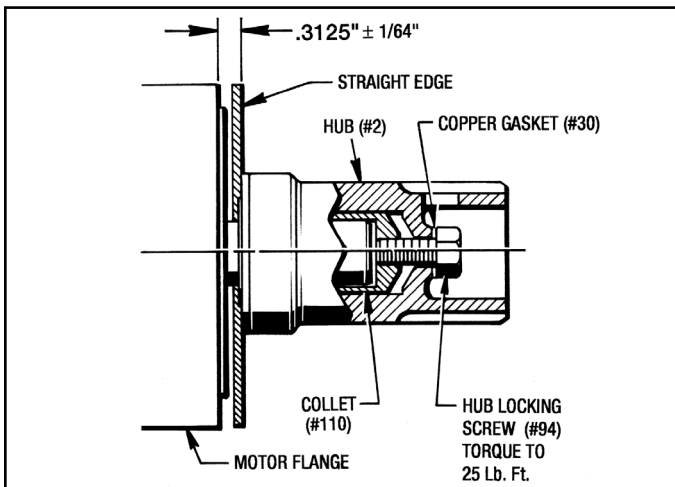

Figure 3 - Hub Alignment

2. Back the Screw (#94) out of the Hub and apply a light coat of Loctite (#RC-242) to the screw threads. Reinstall the screw back into the Hub and Collet. Torque to 25 Lb. Ft. to lock the Hub to the Motor Shaft. **NOTE:** Hub will move further onto motor shaft when screw is torqued.

D. ALIGNING TEETH ON FRICTION DISCS (#13)

Check the teeth on the Friction discs (#13) in the Brake Stack to make sure that they are aligned with each other.

If they are out of alignment use the following procedure to align the teeth with each other:

1. First set the Brake Assembly on a work bench with the Housing (#8) and Oil Seal (#31) facing up
2. Apply shop air (Do not exceed 80 PSI) to the brake port to release the spring pressure on the Brake Stack.
3. Manually adjust the Friction Discs so the teeth become aligned with each other. Be careful when reaching in the brake not to damage the Oil Seal (#31).
4. Disconnect the shop air to the Brake Port.

E. INSTALLING BRAKE HOUSING ASSEMBLY

(See Figure 4)

This procedure is for the Horizontal Mounting only. See Section F for Vertical Mounting.

1. Slide the Brake Housing Assembly carefully over the Hub. (See Figure 4)

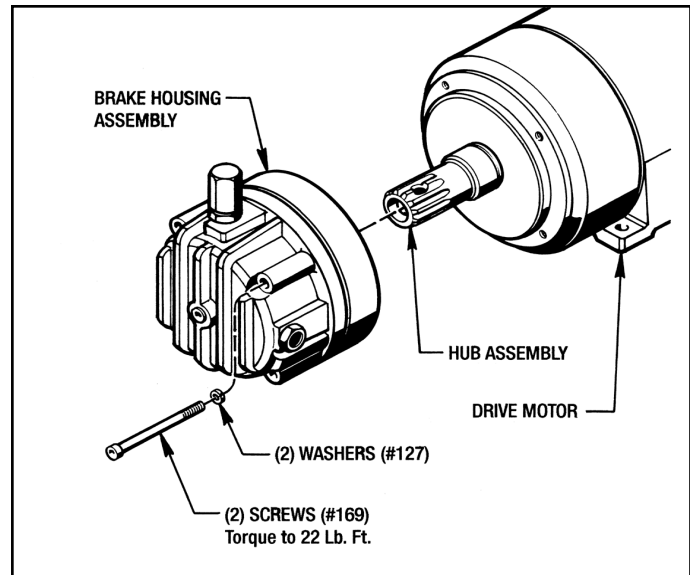

Figure 4 - Installing Brake Housing Assembly

CAUTION

Do not support the weight of the Brake on the lip of the Oil Seal (#31) when sliding the Brake onto the Hub (#2). This could damage the Oil Seal and cause premature failure of the Brake.

Also do not force the Brake Stack onto the hub spline. If any resistance is felt, remove the Brake and realign the teeth again, as described in Section B.

2. Install the (2) Screws (#169) and (2) Washers (#127) and Torque to 22 Lb. Ft.

3. Check to see if the Air Breather (#45), Sight Gauge (#46) and all Pipe Plugs are installed tightly.
4. Add Automatic Transmission Fluid (Mobil ATF 210) until the fluid level is in the center of the Sight Gauge.
5. Install appropriate external pneumatic valving. See *Figure 8* for a typical Pneumatic Schematic.

F. VERTICAL MOUNTING INSTRUCTIONS

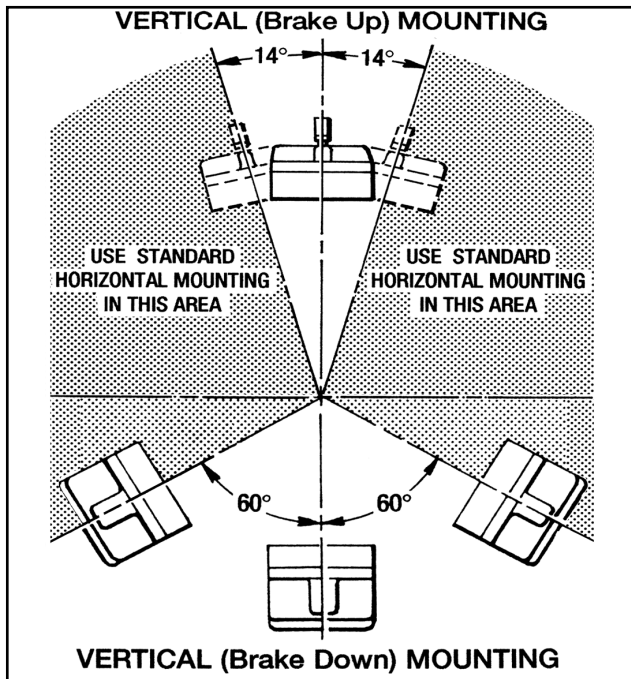

Figure 5 - Vertical Mounting

• VERTICAL MOUNTING (Brake Up)

Converting to a **VERTICAL MOUNTING (Brake Up)** is a simple procedure of just switching the Air Breather and some Pipe Plugs around in the Brake Unit. (See *Figure 6*)

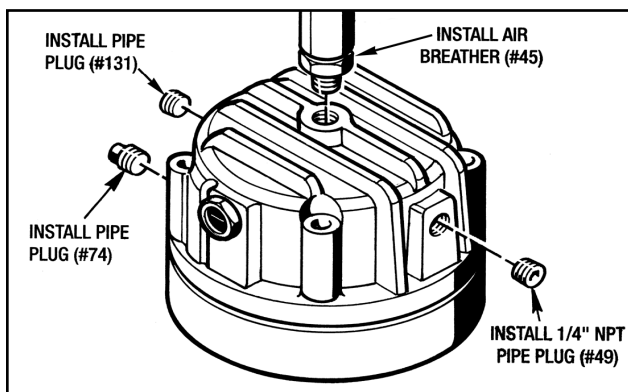

Figure 6 - Converting To Vertical Brake Up

The Procedure for Conversion is as follows:

1. First drain all of the oil out of the brake into a suitable container and save or discard as condition warrants.
2. Switch the Air Breather (#45) and the Pipe Plug (#49) around in the End Housing (#9).

3. Switch the 1/8" NPT Pipe Plugs (#74) and (#131) around.

NOTE: Use pipe sealant with Teflon (59241) on all pipe threads.

4. Refill the Brake Unit with Mobil ATF-210 Automatic Transmission Fluid to the center of the Sight Gauge (#46).

CAUTION: Do not over fill. This could cause the Brake to overheat and fail prematurely

• VERTICAL MOUNTING (Brake Down)

A Conversion Kit is necessary to convert the MB-056 from a Horizontal Mounting to a **VERTICAL MOUNTING (Brake Down)** installation. This Kit is shown in *Figure 7*.

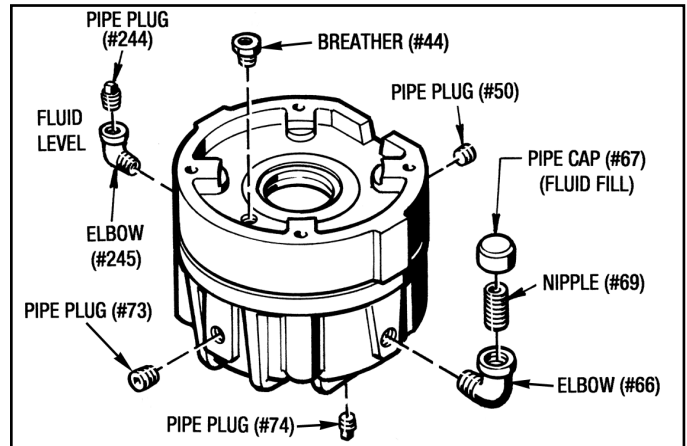

Figure 7- Vertical Mounting Kit (Brake Down)

NOTE: Use pipe sealant with Teflon (59241) on all pipe threads.

The procedure for conversion is as follows:

1. First drain all of the oil out of the brake into a suitable container and save or discard as condition warrants.
2. Remove the Sight Gauge (#46) from the End Housing (#9) and install a 3/8" NPT Street Elbow (#66), 3/8" NPT x 1-1/2" Lg. Pipe Nipple (#69) and a 3/8" NPT Pipe Cap (#67) back into the hole. This will be the Fluid Fill.
3. Remove the Breather (#45) and install a 1/4" NPT Pipe Plug (#73).
4. Remove 1/8" NPT Pipe Plug (#50) from the side of the housing (#9) and install 1/8" Street Elbow (#245) and 1/8" NPT Pipe Plug (#244).
5. Switch 1/8" NPT Pipe Plug (#50) from the end of Housing (#9) with 1/8" NPT Pipe Plug (#74). Then take out the 1/8" NPT Pipe Plug (#75) from the Housing (#8) and replace it with the Breather (#44).
6. Remove the Pipe Plug (#244) and the Pipe Cap (#67) and fill with Mobil ATF-210 Automatic Transmission Fluid until it starts to run out of the Street Elbow (#245). Replace the Pipe Plug (#244) when full.

CAUTION: Do not over fill. This could cause the Brake to overheat and fail prematurely

G. PNEUMATIC INSTALLATION

1. Use direct acting or pilot operated solenoid air valves to give the correct response speed required. Locate the valve as close to the brake as possible.
2. Be sure to use valves of at least .4 Cv.
3. The **minimum** air pressure to release the Posistop brake is 20 psi for 6 lb.ft. brake torque, 30 psi for 9 lb.ft. brake torque, 40 psi for 12 lb.ft. brake torque, and 60 psi for 18 lb.ft. brake torque.
4. Hook-up appropriate electrical service to the Solenoid Control

Valve as per manufacturers specifications.

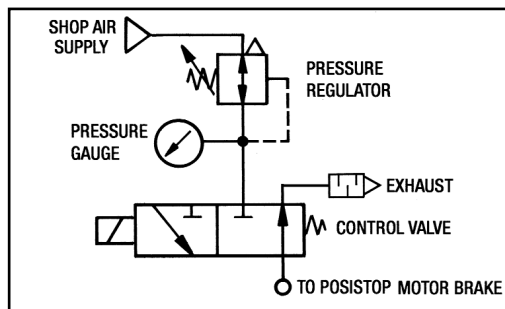

Figure 8 - Pneumatic Diagram

LUBRICATION

A. CHECKING THE OIL LEVEL

Check the oil level when the drive is installed and weekly thereafter (until experience dictates otherwise). Always check the oil level with the unit stationary (not running).

NOTE:

Oil Gauge (#46) and Pipe Plug (#49) may be reversed so that level is visible from other side

B. CHANGING THE OIL

Every twelve (12) months remove Drain Plug (#74) and (#131) at the bottom of the End Housing (#9) and Housing (#8). Drain all oil before refilling. More frequent

oil change may be required on high kinetic energy applications or in extremely dirty environments.

Check the Oil Sight Gauge (#46) for dirt. Remove and clean if necessary. Replace the drain plugs. Refill unit with clean oil up to the center of the sight gauge. The capacity of your MB-056 Motor Brake is 6 ounces of oil.

CAUTION: Do not over fill with oil. Excess oil will cause the unit to overheat

C. TYPE OF OIL

Use Automatic Transmission Fluid, Mobil ATF-210 (type F) or Mobil Multi-Purpose Automatic Transmission Fluid.

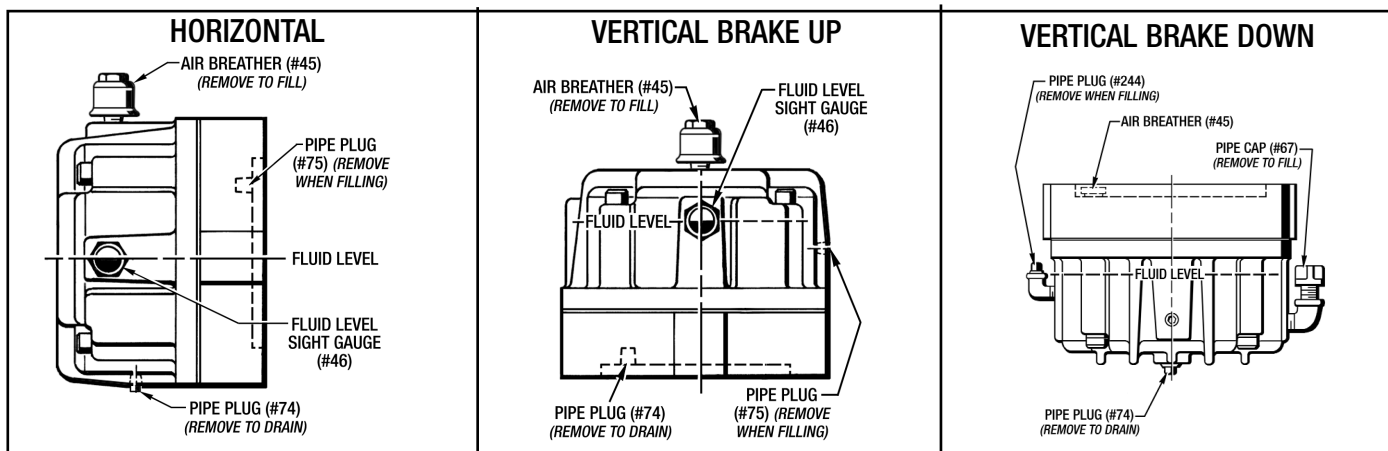

Figure 9 - Lubrication

FACTORY REBUILD SERVICE & COMPLETE SERVICE MANUALS

A. FACTORY REBUILD SERVICE

A Factory Rebuild Service is offered by Force Control Industries, Inc. Contact our service and sales department at Force Control for additional information

B. COMPLETE SERVICE MANUALS

A complete Service Manual can be downloaded and printed off of our web site. Go to: www.forcecontrol.com

All of our Catalogs and Service Manuals on the web site are in PDF format and will require Adobe Acrobat Reader 5.0 or later to open them. This Adobe Acrobat Reader can be downloaded from our web site if you do not have it installed on your computer.



FORCE CONTROL INDUSTRIES, INC.

3660 Dixie Highway
Fairfield, Ohio 45014

Phone: 513-868-0900

Fax: 513-868-2105

E-Mail: info@forcecontrol.com

Web Site: www.forcecontrol.com