

WORLDWIDE LEADER IN OIL SHEAR TECHNOLOGY

MAGNASHEAR™ BRAKE MOTORS

DESIGNED FOR SEVERE DUTY APPLICATIONS

MagnaShear Oil Shear Brake mounted on a HEAVY DUTY Baldor Cast Iron Motor

1 Thru 5 hp in Stock, or available for Quick Delivery

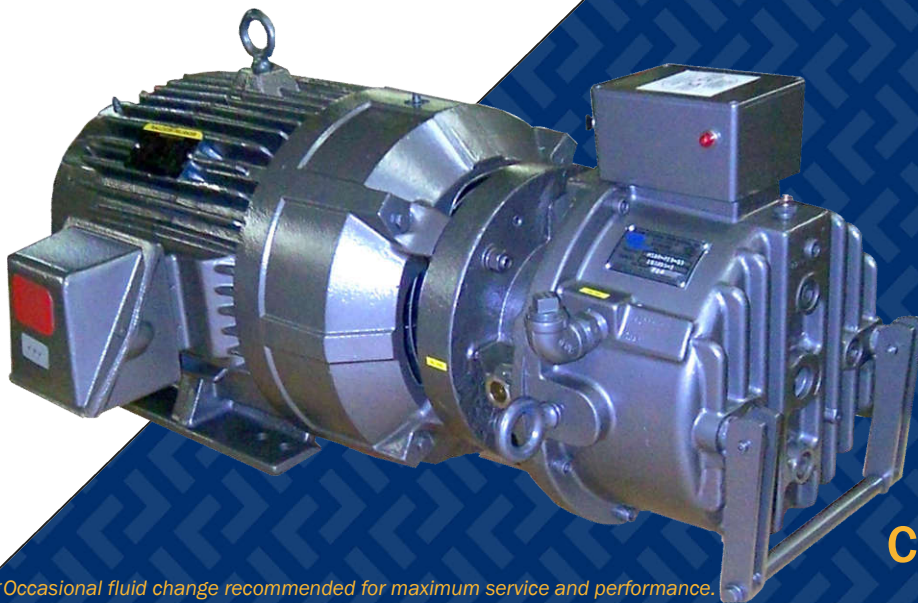

**Occasional fluid change recommended for maximum service and performance.*



BENEFITS:

- 5 to 10 times Longer Life
- No Regular Maintenance*
- No Adjustment—Ever!
- Totally Enclosed Sealed Unit

APPLICATIONS

Concrete Block Plants, Steel Mills, Foundry's, Roofing Plants, Fiberglass Insulation, Tire Plants, Lumber Mills, Overhead Cranes, Plating Lines, Coal and Mineral Processing, Marine Winches & Capstans, Food & Packaging.

CHECK STOCK TODAY

800-829-3244

info@forcecontrol.com

Chat: www.forcecontrol.com



**MADE IN THE USA
USED WORLDWIDE**

www.forcecontrol.com

**HIGH CYCLE—SEVERE DUTY BRAKES
YEARS OF MAINTENANCE FREE SERVICE**

FORCE CONTROL INDUSTRIES, INC.
3660 Dixie Hwy. | Fairfield, OHIO 45014
Phone: 513-868-0900 | 800-829-3244
Email: info@forcecontrol.com

REPLACE THOSE OLD MOTORS AND DRUM STYLE BRAKES!



REPLACE THIS

WITH THIS

Made In America MAGNASHEAR OIL SHEAR BRAKE on a Heavy Duty Cast Iron Motor.

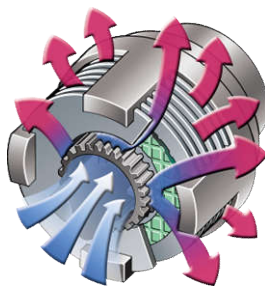
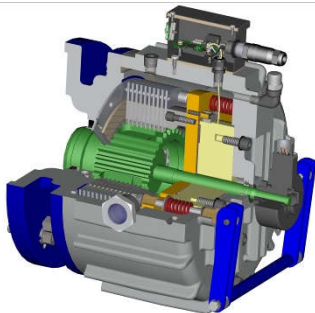

STOCK/QUICK SHIP LIST*

1 H.P./1800 R.P.M. Brake Motor

Baldor Cast Iron, T.E.F.C., C-Face Output Motor With Feet, 143TC Frame, 230/460 Volt, 60 Hertz, 3 Phase, Design B, Class F Insulation, F1 Conduit Location. Available Torque 6, 8, 12, 14, 21, 33 Lb. Ft.

Motor Model **#3-RE3W3C1A2F1** MagnaShear **MSB2** or **MSB4** Brake.

1.5 H.P./1800 R.P.M. Brake Motor

Baldor Cast Iron Motor, T.E.F.C., C-Face Output With Feet, 145TC Frame, 230/460 Volt, 60 Hertz, 3 Phase, Design B, Class F Insulation, F1 Conduit Location. Available Torque 6, 8, 12, 14, 21, 33 Lb. Ft.

Motor Model **#3-RF3X3C1A2F1** MagnaShear **MSB2** or **MSB4** Brake

2 H.P./1800 R.P.M. Brake Motor

Baldor Cast Iron Motor, T.E.F.C., C-Face Output With Feet, 145TC Frame, 230/460 Volt, 60 Hertz, 3 Phase, Design B, Class F Insulation, F1 Conduit Location. Available Torque 6, 8, 12, 14, 21, 33 Lb. Ft.

Motor Model **#3-RG3X3C1A2F1** MagnaShear **MSB2** or **MSB4** Brake

3 H.P./1800 R.P.M. Brake Motor

Baldor Cast Iron Motor, T.E.F.C., C-Face Output With Feet, 182TC Frame, 230/460 Volt, 60 Hertz, 3 Phase, Design B, Class F Insulation, F1 Conduit Location. Available Torque 14, 21, 33 Lb. Ft.

Motor Model **#3-RH3Y3C1A2F1** MagnaShear **MSB4** Brake

5 H.P./1800 R.P.M. Brake Motor

Baldor Cast Iron Motor, T.E.F.C., C-Face Output With Feet, 184TC Frame, 230/460 Volt, 60 Hertz, 3 Phase, Design B, Class F Insulation, F1 Conduit Location. Available Torque 14, 21, 33 Lb. Ft.

Motor Model **#3-RH3Y3C1A2F1** MagnaShear **MSB4** Brake

**Subject to Availability*

OTHER AVAILABLE SIZES#

7.5 H.P./1800 R.P.M. Brake Motor With MSB4 MagnaShear Brake

Baldor Cast Iron Motor With Feet, 213T Frame, 230/460 Volt, 60 Hertz, 3 Phase, Design B, Class F Insulation, F1 Conduit Location. Available Torque 14, 21, 33 Lb. Ft.

10 H.P./1800 R.P.M. Brake Motor With MSB6/MSB7 MagnaShear Brake

Baldor Cast Iron Motor With Feet, 215T Frame, 230/460 Volt, 60 Hertz, 3 Phase, Design B, Class F Insulation, F1 Conduit Location. Available Torque 38,62,86,100,130, 170 Lb. Ft.

15 H.P./1800 R.P.M. Brake Motor With MSB6/MSB7 MagnaShear Brake

Baldor Cast Iron Motor With Feet, 254T Frame, 230/460 Volt, 60 Hertz, 3 Phase, Design B, Class F Insulation, F1 Conduit Location. Available Torque 38,62,86,100,130, 170 Lb. Ft.

20 H.P./1800 R.P.M. Brake Motor With MSB7/MSB8 MagnaShear Brake

Baldor Cast Iron Motor With Feet, 286T Frame, 230/460 Volt, 60 Hertz, 3 Phase, Design B, Class F Insulation, F1 Conduit Location. Available Torque 95, 130, 150, 170, 200, 250 Lb. Ft.

30 H.P./1800 R.P.M. Brake Motor With MSB7/MSB8 MagnaShear Brake

Baldor Cast Iron Motor With Feet, 256T Frame, 230/460 Volt, 60 Hertz, 3 Phase, Design B, Class F Insulation, F1 Conduit Location. Available Torque 95, 130, 150, 170, 200, 250 Lb. Ft.

50 H.P./1800 R.P.M. Brake Motor With MSB9 MagnaShear Brake

Baldor Cast Iron Motor With Feet, 326T Frame, 230/460 Volt, 60 Hertz, 3 Phase, Design B, Class F Insulation, F1 Conduit Location. Available Torque 250, 300, 350, 450, 500 Lb. Ft.

**Delivery subject to motor availability*

MADE IN AMERICA—SHIPPED WORLDWIDE

Force Control Industries, Inc. Fairfield, OHIO USA

Phone: 513-868-0900 | 800-829-3244

Email: info@forcecontrol.com

