



Built to Last

# MagnaShear Coupler Brake

The MagnaShear™ Oil Shear Spring Set Coupler brake is designed to eliminate the need to purchase a special brake motor and use a standard off the shelf C-face motor. With the MagnaShear brake's extremely long service life and "no adjustment needed – ever!" performance, the brake requires no more maintenance than the motor.



## MagnaShear™ Electrically Actuated Oil Shear Coupler Brakes for Severe Duty Applications

- Never Needs Adjustment – Ever!
- Lasts 5 to 10 Times Longer Than The Competition
- Quick Mount Installation - Slide it On, Tighten the Bolts, That's it
- 2 sizes to fit motor frames 56 to 145T
- Torque Range - 6 Lb. Ft. to 33 Lb. Ft.
- Totally Enclosed - Water and Dust Tight
- Clamped-Split-Quill Shaft Connection - Eliminates Keyway - Excellent for Reversing Applications.

The MagnaShear™ Oil Shear Coupler brake is designed for those difficult stopping and holding applications. Multiple disc oil shear technology delivers superior dynamic braking, high thermal capability, and 5-10 times longer life with "no adjustment – ever!".

The MagnaShear™ Oil Shear Coupler Brake is also excellent for positioning accuracy and repeatability.

Using 115 VAC to release the spring set brake eliminates the need for compressed air. Use the optional step down transformer to wire to motor leads or special voltages.

The new quick mounting and the split clamped quill offer superior shaft connection and ease of installation.

Washdown Duty units are available for use in food processing, Marine Duty for ports, cranes and marine winches.

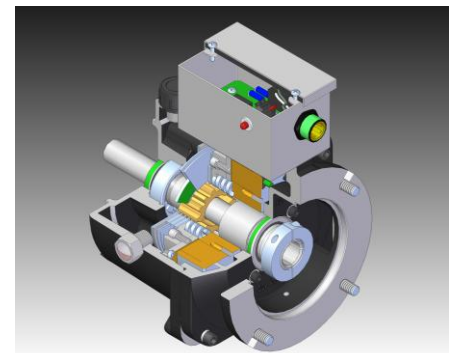

***Built in the USA – Sold Worldwide***

***Since 1969***

**Force Control Industries, Inc**

Phone: (513) 868-0900 Fax: (513) 868-2105

[www.forcecontrol.com](http://www.forcecontrol.com) [info@forcecontrol.com](mailto:info@forcecontrol.com)



# MagnaShear Coupler Brake

## SELECTION

MOTOR FRAME	56	143	145	182	184
MSB2	X	X	X	--	--
MSB4	--	--	--	X	X

## Specifications

BRAKE SIZE	MNTG. B.C.	BORE	QTY. SPRINGS	STATIC TORQUE	DYNAMIC TORQUE	MAX KE PER ENGMT. FT.LB.	INERTIA LB.FT. <sup>2</sup>	INPUT VOLTAGE
MSB2	5.875	.875	3	6	5	7,975	0.011	115 VAC OR 230 VAC
			4	8	7			
			6	12	10			
MSB4	7.250	1.125	3	14	12	22,000	0.024	115 VAC OR 230 VAC
			4	21	18			
			6	33	28			

## Dimensions

SIZE	U/FU	AK/FAK	AG	AA	AB	F	G
MSB2	.875	4.5	7.00	3.44	4.04	3.44	6.78
MSB4	1.125	8.5	8.67	4.40	5.00	4.40	6.92

