

WORLDWIDE LEADER IN OIL SHEAR TECHNOLOGY

MAGNASHEAR™

**SPRING SET—ELECTRIC RELEASE
MOTOR BRAKES FEATURING OIL
SHEAR TECHNOLOGY**

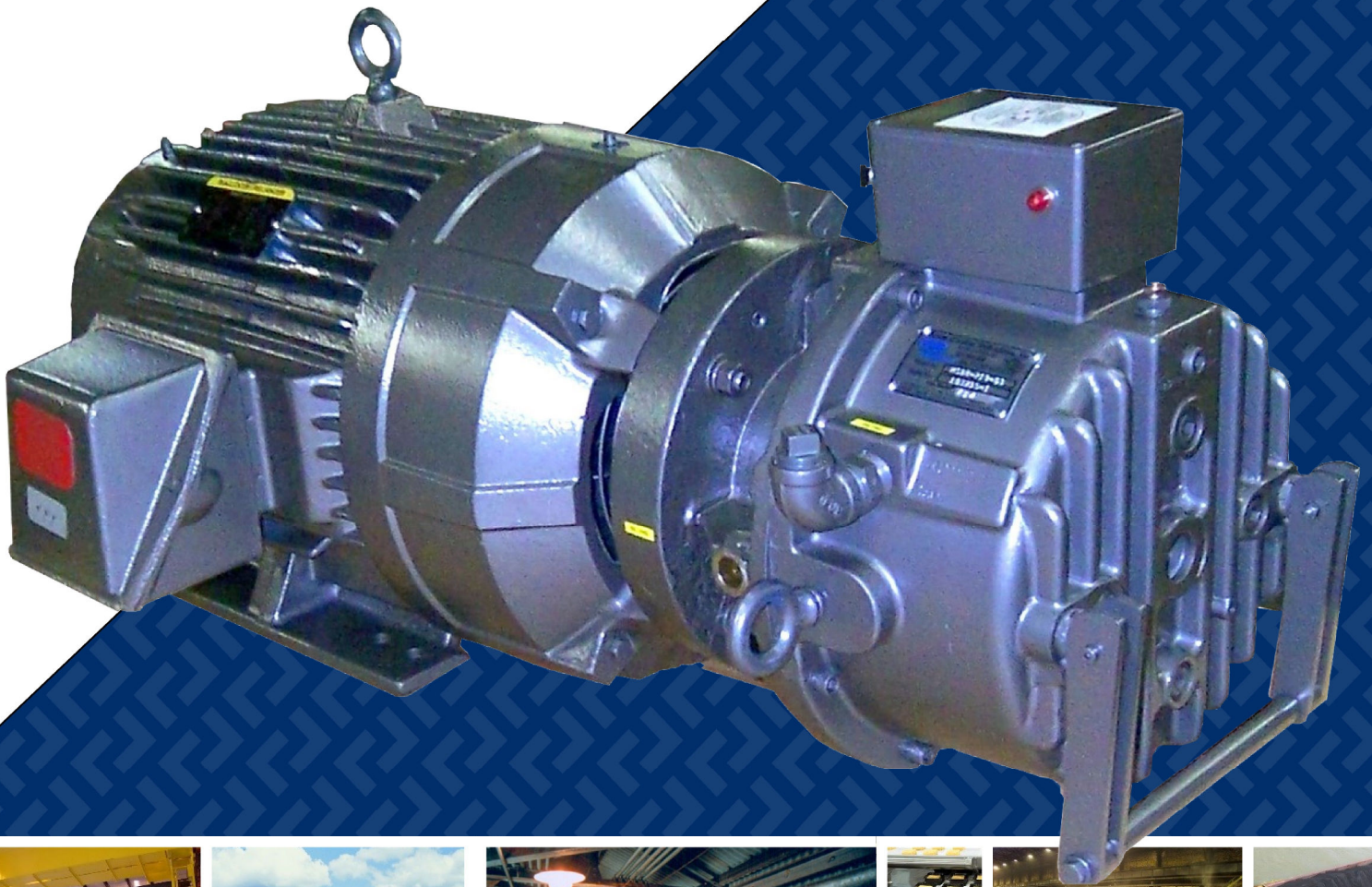

**NO ADJUSTMENT—EVER!
YEARS OF MAINTENANCE FREE SERVICE**

ISO 9001 CERTIFIED

> FORCECONTROL.COM

OIL SHEAR TECHNOLOGY

Oil Shear Technology Provides Force Control Clutches and Brakes With Increased Cycle Life, Higher Cycle Rates, and Lower Cost per Cycle.

The MagnaShear motor brakes with Oil Shear Technology are of the wet or hydroviscous type which transmit torque between the drive plates and friction surfaces. Specially formulated transmission fluid is used for cooling and provides a hydroviscous fluid film between the friction disc and the drive plate during the dynamic phase of engagement.

The transmission fluid in shear transmits torque between the two components increasing as the clamping pressure increases until mechanical lock up occurs. By cooling the friction surfaces and reducing the mechanical wear, a significant increase of thermal capacity and total cycle life is possible.

Many competitive clutches and brakes depend on friction between dry surfaces surrounded by air to transmit torque. During engagement of dry surfaces, high heat caused by slipping is difficult to dissipate quickly causing wear, glazing, and friction material degradation. This in turn causes

positioning inaccuracy, limited service life, and possible safety issues.

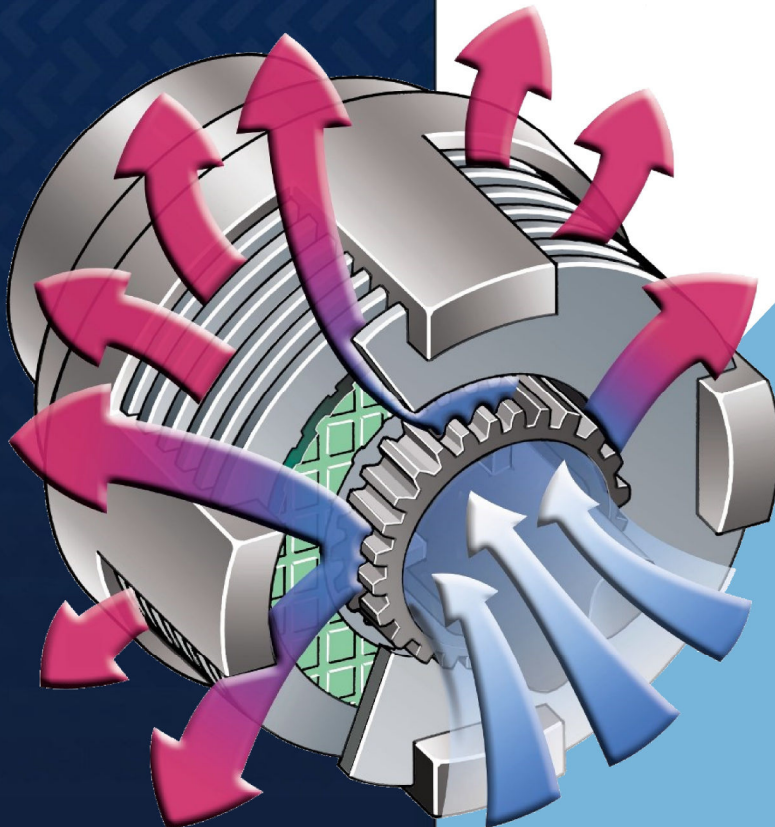

THE ADVANTAGES OF MAGNASHEAR BRAKES WITH OIL SHEAR TECHNOLOGY

- **LONGER LIFE** - in typical applications it is not unusual to see 5 to 10 times the service life of most competitive products.
- **NO REGULAR MAINTENANCE*** - There is no regular maintenance replacing friction discs, pads, or shoes, bearings, O-rings, or coils.
- **NO ADJUSTMENT - EVER!** - The unique design and Oil Shear Technology eliminate the need for regular adjustment.
- **LOWER COST PER INDEX** - Reduced maintenance, no adjustment and Longer life = lower cost per index.
- **LESS DOWN TIME** - The unique design, high quality components and Oil Shear Technology mean less chance of failure causing unexpected downtime.
- **HIGHER CYCLE RATES** - Oil Shear Technology enables higher cycles rates by continuously removing heat in the friction stack.
- **QUIETER OPERATION** - the combination of Oil Shear Technology and the heavy duty sealed housings eliminate the sharp noise of engagement and eliminate any squeal of acceleration or deceleration.
- **IMPROVED EFFICIENCY** - Low rotating inertia and reduced power consumption with the PWM board improves efficiency.
- **IMPROVED SAFETY** - No need for adjustment, and the reliable long term service life, nearly eliminates the need to work on the brake. This not only improves the safety record of the maintenance worker, but reduces the chance of injury due to unexpected brake failure.

**Annual fluid change recommended for maximum performance and life.*

OIL SHEAR TECHNOLOGY

Specially formulated transmission fluid is used for cooling and provides a hydroviscous fluid film between the friction discs and drive plates during the dynamic phase of engagement.

MAGNASHEAR BRAKE APPLICATIONS, INDUSTRIES & SPECIFICATIONS

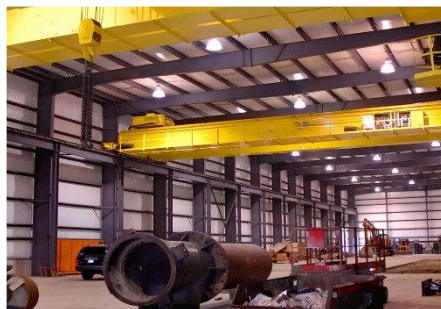

SUCCESSFUL APPLICATIONS

- Cranes/Winches/Hoists
- Palletizing
- Conveying
- Indexing
- Turn Overs/Dumpers
- Coal Sampling
- Production Machines
- Automotive Production
- Marine Winches/Hoists

TYPICAL INDUSTRIES

- Lumber
- Mining
- Packaging
- Steel
- Fabrication
- Pipe Mills
- Food Processing
- Meat Packing
- Breweries
- Bottling Plants
- Military
- Concrete Blocks
- Ice Cream
- Bakeries
- Candy
- Rail Loading/Unloading

SPECIFICATIONS

- Spring Set Electric Release
- Torque 6 Lb. Ft. to 1250 Lb. Ft.
- Fits NEMA Frame 56 to 440 motor frames.
- IEC and Custom frame available
- Wash Down, Marine Duty, Hazardous Duty, Crane Duty
- Manual Release, lock out, and released indicator available
- Can also be furnished as an assembled brake motor.

OPTIONS & ACCESSORIES

CRANE DUTY BRAKES

The MagnaShear crane duty brakes are designed for the high cycle, jogging operation experienced by many overhead crane applications. The heavy duty cast housings, multiple disc, direct acting magnet, and split clamped or splined quill all

make the MagnaShear brakes reliable and safe.

Oil Shear Technology adds smooth engagement, high heat absorption, quiet operation, and 5 to 10 times longer life with no regular maintenance and no adjustment – ever!

Many crane brakes are custom designed by the crane manufacturer to fit special motors or gearboxes. Force Control can modify the MagnaShear brakes to fit many of these custom applications.



WASHDOWN/MARINE DUTY

The purpose of the washdown option is to prevent corrosion and liquid ingress from exposure to rain, water, salt water spray, or high pressure wash down.

The MagnaShear motor brakes are by design totally enclosed in heavy duty cast iron or cast aluminum housings. Corrosion is controlled using nickel plated shafts, stainless or non-ferrous bolts, sight gauges, breathers, clamp collars, and a corrosion resistant epoxy coating, typically Steel It. Preventing the ingress of water or other fluids is sealed breathers, shaft seals, and housing/conduit box seals.

Food grade fluid is used for food processing applications and bio-degradable fluid is used for marine duty units.



HAZARDOUS DUTY Hazardous Duty brakes are required where there is a potential of fire or explosion due to flammable materials. The size MSB2 through MSB10 is available in a hazardous duty design certified to meet UL Class I and II Division 2, Groups a, b, c, d, e, f & g specifications.

LOW TEMPERATURE The MagnaShear brakes can be modified for low temperature operation to -40 degrees. A special synthetic fluid is used and internal heaters keep the fluid warm.

ASSEMBLED BRAKE MOTOR For a complete replacement, or new application Assembled Brake Motors are available. The assembled brake motor consists of a MagnaShear brake, professionally mounted on a motor, and fully tested. The entire assembly can be standard, hazardous duty, marine duty, washdown duty, and even extreme low temperature.

Various motor brands are available depending on the manufacturers availability.

MANUAL RELEASE Designed to allow manual release of the brake when power is off. This allows movement of the machine for maintenance purposes while the power is locked out.

RELEASE INDICATOR SWITCH A mechanical switch that indicates the brake is released. This can be used to disable starting the motor if the switch indicates the brake is not released.

SPLINE QUILL Especially when doing a retrofit on a crane, a splined shaft is often found. This requires a splined quill. Force Control Industries can make splined quills with a drawing or by making a mold of the existing spline.

STUB SHAFT There are times when an encoder is required, especially with VFD drives. The optional shaft extension out the back of the brake is ideal for mounting an encoder.

STEEL-IT EPOXY COATING SYSTEM A Steel-It epoxy coating protects the housing from most common moisture or chemical agents. The STEEL-IT Epoxy Coating System utilizes a unique stainless steel leafing pigment. This catalyzed system creates a hard, non-toxic, metallic finish that safeguards a wide variety of materials from the effects of ultraviolet rays, chemicals, oils, alkalis, food acids, water immersion, abrasion, and high pressure wash downs.

STEP DOWN TRANSFORMER The MagnaShear brakes are designed to operate on 115 or 230 Volt AC input power. For best performance this should come from the main motor switch panel auxiliary contactor. A 230 VAC brake can be wired directly to the motor leads on a dual voltage 230/460 VAC motor.

For other voltages a step down transformer is required. This makes a single brake available for many voltages such as 460 VAC, 575 VAC, 360VAC as well as 50 or 60 Hz.

Wiring any brake directly into the motor leads can cause problems such as premature coil failure and sluggish response due to back emf. However it is often done for convenience.

SIZING A MAGNASHEAR BRAKE Sizing a MagnaShear brake is determined by the frame size of the motor, and the dynamic torque required to stop the load within the required time.

The brake model is determined by the frame size of the brake end of the motor.

Dynamic brake torque is determined using the following formula.

$$T = \frac{WK^2 (Inertia) \times RPM \times 2}{308 \times Time (to stop)}$$

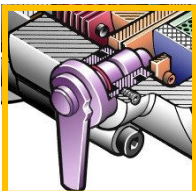

Manual Release

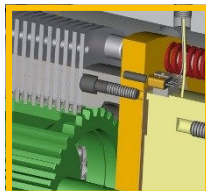

Manual Release Indicator Switch



Washdown/ Marine Duty



Stub Shaft w/ Encoder



Hazardous Duty



Crane Duty



Step Down Transformer



CONTACT FORCE CONTROL

Force Control Industries, Inc.
P: 513/868/0900 f: 513/868/2105
info@forcecontrol.com
ForceControl.com



MagnaShear Specifications and Dimensions—Standard, Hazardous Duty, Crane Duty

Brake Size	Torque (Lb. Ft.)		Motor Frame	Pilot Dia. FAK (in.)	Bolt Circle FAJ (ins.)	Hub Bore Dia. FU (In.)	Hub Depth Min/Max (In.)	L Overall Length (In.)	L2 Max Length (In.)	H Height (In.)	W Width (In.)	Oil Capacity (Fl. Oz)	Weight (Lb.)	
	Static	Dynamic												
MSB2	6	5	56	N/A	5.876	.625-.875	1.00-2.19	7.96	10.02	10.26	9.84	28	21	
MHD2	8	7	143											
MCB2	12	10	145											
MSB4	14	12	182	N/A	5.875 7.250	.875-1.125	1.37-2.89	9.74	10.10	10.25	10.75	40	50	
MHD4	21	18	184											
MCB4	33	28	213 215											
MSB6	38	32	213	N/A	7.25	.875-1.625	2.00—3.75	10.55	12.70	12.60	11.82	80	65	
MHD6	62	53	215											
MCB6	86	73	254											
	100	85	256											
MSB7	95	83	254	8.50 10.50	7.25 9.00	1.375-1.875	3.00-4.38	12.40	19.30	15.46	19.10	50	70	
MHD7	135	115	256											
MCB7	170	148	284 286											
MSB8	100	86	254	8.50 10.50 12.50	7.25 9.00 11.00	1.375-1.875	3.00-4.38	14.82	19.30	15.21	19.10	180	170	
MHD8	150	129	256											
	200	172	284											
MCB8	250	215	286											
MSB9	250	215	284	10.50 12.50	9.00 11.00	1.625-2.375	2.75-4.62	15.51	19.48	17.77	16.84	192	270	
	300	258	286											
	MHD9	350	301											324
		450	387											326
	MCB9	500	430											364 365 404 405
MSB10	600	516	284	10.50 12.50	9.00 11.00	1.875-2.375	2.75-4.62	15.40	19.75	17.44	18.39	192	270	
	650	559	286											
	750	645	324											
	900	774	326											
MSB12	625	538	444	16.00	14.00	1.875-3.625	3.00-5.12	23.35	30.54	23.4	20.10	384	600	
	950	817	445											
	1250	1075	447 449											

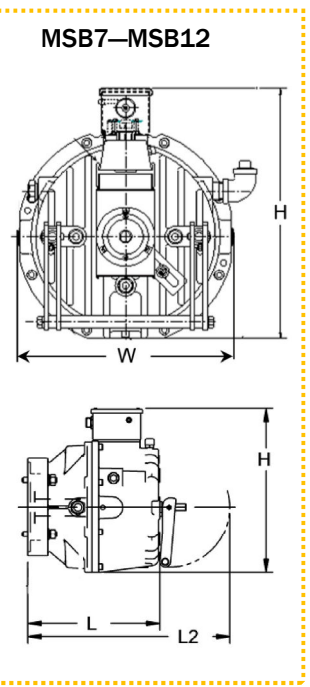
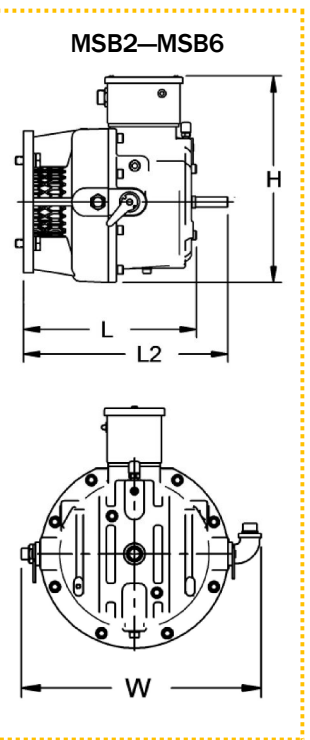

Note: All dimensions are approximate and may vary with model or options. Request certified drawings. See website www.forcecontrol.com for additional information.

HOW TO ORDER A MAGNASHEAR MOTOR BRAKE

MSB—Standard Motor Brake MCB—Crane Duty Brake MHD—Hazardous Duty

MSB MCB MHD	1	2	3	4	5	6	7	8	9
(1) Brake Size	2 =MSB2, MCB2, MHD2 4 =MSB4, MCB4, MHD4 6 =MSB6, MCB6, MHD6 7 =MSB7, MCB7, MHD7 8 =MSB8, MCB8, MHD8 9 =MSB9, MCB9, MHD9 A =MSB10, MCB10, MHD10 C =MSB12, MCB12	(2) Pilot Dia. (FAK) 4 =MSB2 (5.875 Dia.) 5 =MSB4 (5.875 Dia. & 7.250 Dia.) Q =MSB6, MSB7, MSB8 (8.50" Dia.) R =MSB7, MSB8, MSB9, MSB10 (10.50" Dia.) S =MSB9, MSB10 (12.50" Dia.) T =MSB12 (16.00" Dia.)	(3) Mounting Position H =Horizontal Standard (All Sizes) J =Horizontal high oil level (Except MSB2, 4 & 6) Z =Horizontal Marine Duty (Except MSB2, 4 & 6) F =Horizontal Washdown Duty U =Vertical Brake Up (Except MSB12) D =Vertical Brake Down (Except MSB12) P =Vertical Brake Up Marine Duty W =Vertical Brake Down Marine Duty G =Vertical, Brake Up Washdown Duty K =Vertical Brake Down Washdown Duty	(4,5,6) Torque Size MSB2 006 =6 Lb. Ft. 008 =8 Lb. Ft. 012 =12 Lb. Ft. Size MSB4 014 =14 Lb. Ft. 021 =21 Lb. Ft. 033 =33 Lb. Ft. Size MSB6 038 =38 Lb. Ft. 062 =62 Lb. Ft. 086 =86 Lb. Ft. 100 =100 Lb. Ft. Size MSB7 95 =95 Lb. Ft. 135 =135 Lb. Ft. 170 =170 Lb. Ft. Size MSB8 100 =100 Lb. Ft. 150 =150 Lb. Ft. 200 =200 Lb. Ft. 250 =250 Lb. Ft.	(7) Manual Release R =Manual Release (not available on MSB2) B =Manual Release with Encoder Stub Shaft (not available on MSB2) A =Encoder Stub Shaft (no release) (not available on MSB2) S =None (Std. on MSB2 & 4)	(8) Bore Dia. A =.625" 0 =.875" 1 =1.125" 2 =1.250" 3 =1.375" 4 =1.500" 5 =1.625" 7 =1.875" B =2.000" C =2.125" D =2.250" E =2.375" G =2.625" J =2.875" K =3.000" N =3.125" P =3.375" Q =3.500" R =3.625"	(9) Voltage 1 =115 VAC Release indicator switch included 2 =230VAC Release indicator switch included = 115 VAC B Block Plant Only (Besser 3 pin)		

MAGNASHEAR™

SPRING SET ELECTRIC RELEASE OIL SHEAR MOTOR BRAKES

WHAT IS A MAGNASHEAR SPRING SET ELECTRIC RELEASE OIL SHEAR MOTOR BRAKE?

MagnaShear Spring Set Electric Release Motor Brakes are designed to mount to the fan end of a NEMA electric Motor. Mounting to the motor provides a clean package, simple to mount, no alignment issues, no couplings required or special foot mounting bases.

They are used for applications where the motor stops and starts or reverses each index, and needs a brake to stop and hold between cycles.

The MagnaShear brakes are dynamic stopping brakes meaning they can stop a moving load, without damage or wear.

The spring set brake requires no power when holding. Therefore when the power is off, the brake is set and holding. If there is a power failure the brake would come on safely, stopping the machine.

Oil Shear Technology supplies a film of transmission fluid through the friction stack separating the friction discs and drive plates, while dynamically stopping the load. This system removes the heat from the engagement area and nearly eliminates wear. This means no adjustment is ever needed over the life of the brake.

FEATURES OF A MAGNASHEAR BRAKE

- Spring set electrically released - 115 VAC and 230 VAC. Pulse width modulation is used for reduced heat and energy cost. Simple transformers are used for alternate voltages. Some DC actuation is available.
- Direct acting coil eliminates small linkage parts that may corrode, hang up, or fail.
- Multiple disc design for high thermal capacity and low rotating inertia
- Oil Shear Technology for smooth cushioned stops, minimal wear, no adjustment required, superior heat dissipation and consistent, accurate stopping
- Heavy duty totally enclosed sealed housing for protection in severe dusty, dirty, or wet applications.
- Optional wash-down and marine duty designs
- Custom flange designs for IEC, reducer mounting, or old crane retrofits.
- Manual release, release indicator switch (except size 2 and 4), heater, and encoder shaft.
- Quick mount design installs in one piece. No assembling parts on the motor, small parts to drop, covers to remove for adjustment.
- Wash Down, Marine Duty, Hazardous Duty, Crane Duty

