

Force Control Industries Knows Concrete Block Plants

Originator of Oil Shear brakes and clutches

Serving the Concrete Industry Over 40 years

Your one stop shop for repair and replacement of;

- Posidyne Clutch Brakes
- Posistop Brakes
- MagnaShear Brakes
- Warner, Stearns, Dings
- *Bescodyne
- *BescoStop
- *BescoShear
- *Smart Pac Shafts

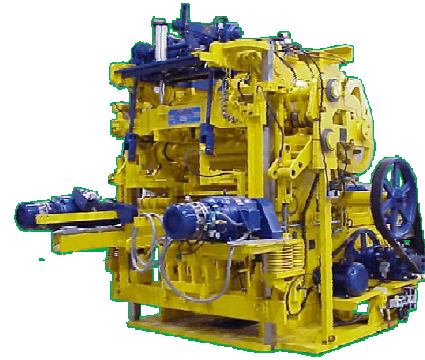

Force Control Industries, Inc.

3660 Dixie Highway Fairfield, Ohio 45014 USA

Phone: 513-868-0900 Fax: 513-868-2105

Web: www.forcecontrol.com Email: info@forcecontrol.com



Force Control Industries, Inc.

3660 Dixie Highway
Fairfield, OH 45014



Force Control Industries Knows Concrete Block Plants

Originator of Oil Shear Brakes and Clutches

Your one stop shop for repair and replacement of Posidyne Clutch Brakes, Posistop Brakes, MagnaShear Brakes *Bescodyne, *BescoStop, *BescoShear, and *Smart Pac Shafts.

Upgrade your Warner, Stearns, Dings and Cisco units to Force Control—reduce maintenance, parts inventory, and overall cost.

*The trademarks Bescodyne®, BescoStop®, BescoShear®, and SmartPac® are the exclusive marks of The Besser Company Alpena, Michigan.

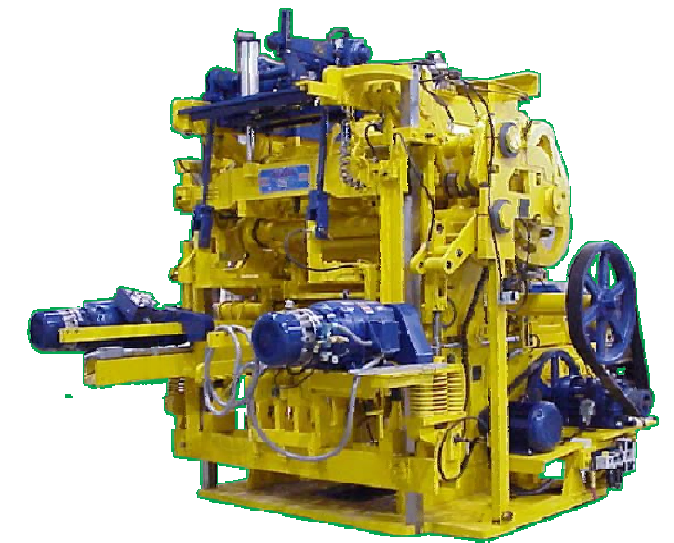

Force Control Industries—Serving the Concrete Industry Over 40 years

- *Design, Manufacture, and Repair oil shear products for the concrete industry*
- *Developing new products such as the MagnaShear electric brake and MagnaShear coupler brake for many of the curing, drying, and storage applications.*
- *Always looking for new products to manufacture. Send us your problem applications.*

For Parts & Service call 800-829-3244

Force Control Industries, Inc.

3660 Dixie Highway Fairfield, Ohio 45014 USA

Phone: 513-868-0900 Fax: 513-868-2105

Email: info@forcecontrol.com

Website: www.forcecontrol.com

MagnaShear Motor Brake

Upgrade to MagnaShear Electric Motor Brakes

- No Adjustment Needed—Ever!
- Consistent Positive Stopping and Positioning
- Totally Sealed—Impervious to Dust and Dirt
- Reduce or eliminate spare parts
- Oil Shear Technology—Lasts 5 to 10 times longer without major maintenance
- Complete assembled brake motors in stock

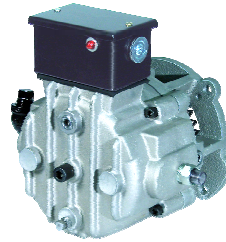

Replace Warner, Nexen, Stearns, Dings, or other dry friction brakes on;

- Conveyors
- Elevators
- Loaders
- Skip Hoists
- Stackers
- Unloaders
- Drying Racks
- Finger Cars
- Spade Drive

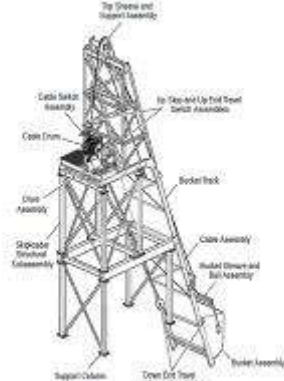
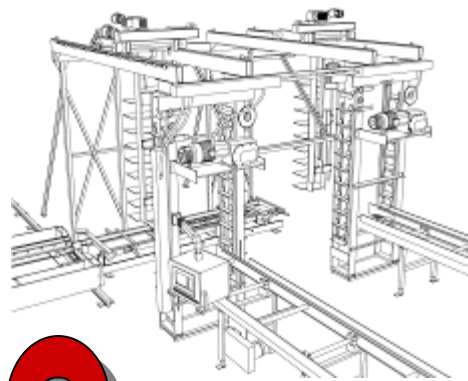

New MagnaShear Coupler Brake

Upgrade to a MagnaShear Coupler brake

For a better deal replace your existing brake motors with a standard C-Face motor and a MagnaShear Coupler Brake

- Inventory one standard motor for braking applications and standard applications.
- Get 5 to 10 times the life of ordinary dry friction brakes.
- Smooth consistent stops in position.



Innovation That Never Runs Dry!

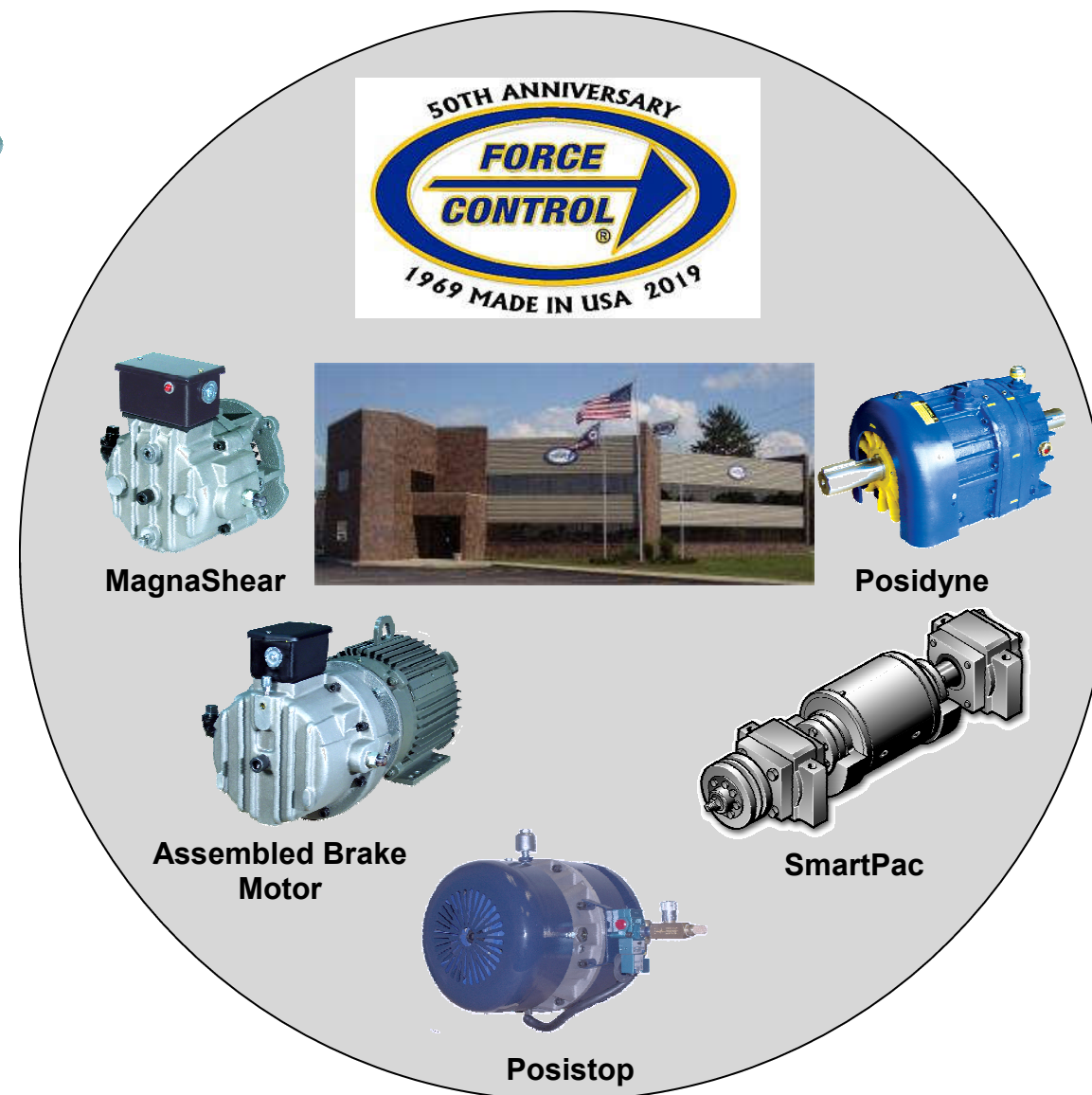

SmartPac

When it's time to repair your SmartPac Vibrator Shaft... have it re-manufactured by factory technicians in a dedicated SmartPac re-manufacturing cell...

Force Control can rebuild your PV2 SmartPac to factory specifications. We are the only facility that has a **dynamic test stand** to fully test every SmartPac before it goes out.

- Longer life, better blocks, less scrap.
- PV1 replacement with an upgraded PV2
- Repair parts available

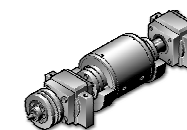

Posistop Motor Brakes

The Oil Shear Posistop brake offers many performance improvements over the Warner brakes on the vibrator drives of some concrete block machines.

- Totally enclosed design
- Incorporates Oil Shear Technology for 5 to 10 times service life
- No adjustment required
- Improved counterweight dropping
- Improved phase control
- Reduced cycle time
- Reduced motor starting torque
- Improved block quality

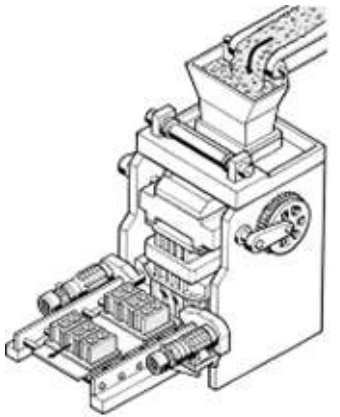

Posidyne Clutch Brakes

The Posidyne Clutch Brakes have been used since the early 70's as a main drive and vibrator drive on some of the major concrete block making machines. Why?

- Extremely long life
- Minimal maintenance—no adjustment, simple fluid check
- Consistent acceleration
- Quick response



Repair / Rebuild

When it comes to repairs come to the original. Replacing a few parts usually means reduced life, and the additional cost to do it again. Get it rebuilt properly;

- New factory warranty from the original manufacturer
- Original OEM parts
- Expedited repair and delivery service
- OEM Rebuild kits available
- Expedited Service – Next Day – Same Day

ERS Emergency Response Service

Force Control stocks complete rebuilt Posidyne clutch brakes at several locations around the country ready for immediate shipment.

- Receive the new Clutch Brake
- Remove old and install new unit
- Return old unit in reusable crate
- You have a full factory warranty



*The trademarks Bescodyne®, BescoStop®, BescoShear®, and SmartPac® are the exclusive marks of The Besser Company Alpena, Michigan.

For Parts & Service call 800-829-3244
Email info@forcecontrol.com