



## NEW PRODUCTS

### Anodizer Eliminates Crane Downtime with Oil Shear Brake Technology

Reprinted From:  
PRODUCTS FINISHING  
Magazine

Operating 24 hours a day, 5 to 6 days a week, there is no convenient downtime for Linetec. The Wausau, Wis., anodizing plant uses a computer-controlled hoist system to guide parts through the anodize process, eliminating any chance of variation in pre-cleaning, etching, anodizing, coloring or sealing.

But any system is only as strong as its weakest link, which in this case were the dry brakes used to stop and position the hoists. They required weekly maintenance and quarterly overhauls, and still experienced periodic failures that brought operations to a standstill. But oil shear brake technology from Force Control Industries slashed downtime and eliminated failures—resulting in unprecedented productivity for Linetec.

There are eight cranes in the Linetec plant—each with a 3-hp trolley motor and a 15-hp hoist motor, each performing roughly 2,000 moves per shift. Previously, dry brakes were mounted on each motor for stopping and positioning. Since these brakes have a sacrificial wear surface (the disc), each one had to be checked weekly and rebuilt on a quarterly basis, a process requiring disassembly, replacement of the disc and solenoid, gap checks, reassembly and restart—all from scissor lifts hoisted nearly 30 feet in the air. Altogether, Linetec was spending 124 hours a year and \$8,000 in parts on preventive maintenance, numbers that don't factor in breakdown and repair.

"If the brakes failed when the line was running, we'd have to shut down production, then go get a scissor lift and the necessary tools and materials," says Linetec Maintenance Supervisor Jon Brubacher. "It was quite time-consuming, and the line is down throughout the entire process." With downtime calculated at \$1,500 per hour, these costs escalated to uncomfortable levels very quickly.

The Linetec team put a single MagnaShear MSB6 motor brake with oil shear technology into service as a trial. After six months with virtually no maintenance and no failures, they were convinced of the viability of the oil shear design, and began formulating a plan for a capital expenditure to replace all of their dry brakes.

Dry clutch brakes employ a sacrificial brake disc or pad to engage the load and absorb heat—heat that will eventually degrade the friction material. As the friction surface wears away and begins to glaze, the spring force is also reduced, causing torque fade and positioning errors that require adjustment or replacement of the friction surface.

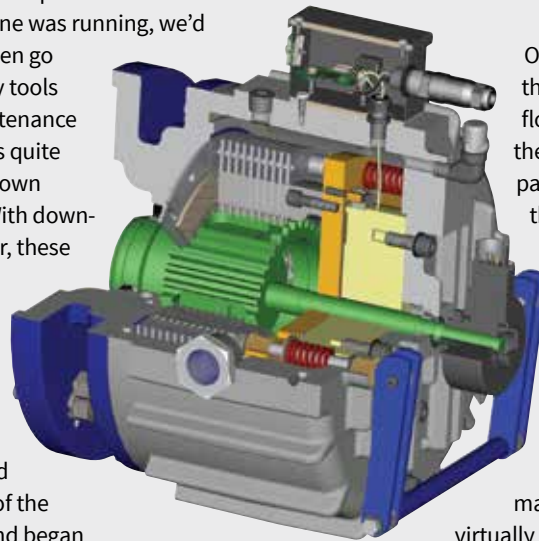

Cutaway of a MagnaShear MSB6 motor brake with oil shear technology.



Before employing oil-shear technology, Linetec's service team constantly had to repair the company's anodizing system's brakes from scissor-lifts hoisted 30 feet in the air. The new system has dramatically reduced brake maintenance.

Oil-shear technology now plays a major role in ensuring that the cranes at Linetec operate continuously. Since a fluid film flows between the friction surfaces, as the brake is engaged, the fluid is compressed. The automatic transmission fluid particles in shear transmit torque to the other side, causing the stationary surface to turn and bringing it up to the same relative speed as the moving surface. By the time the surfaces actually meet, wear is virtually eliminated.

In addition to transmitting torque, a fluid recirculation system helps dissipate heat, while the fluid also continually lubricates the components, thus extending their service life.

Oil shear technology has helped Linetec eliminate brake failures as well as dramatically reduce crane brake maintenance. And that allows the anodizing plant to run with virtually no crane downtime. In addition to increased production, the plant has shaved nearly two hours per week plus another eight hours per quarter from maintenance, cut \$8,000 in annual parts expenditures and put an end to \$1,500 per hour downtime.

"We're very pleased with the performance of the Force Control brakes," says Brubacher. "We have not had a single issue with them since they were installed."

For information on Force Control, please visit their website at [Force-control.com](http://Force-control.com)

FORCE CONTROL INDUSTRIES, INC.

3660 Dixie Hwy • Fairfield, Ohio 45014 USA • 513-868-0900 800-829-3244 • Email: [info@forcecontrol.com](mailto:info@forcecontrol.com) • Web: [www.forcecontrol.com](http://www.forcecontrol.com)