

Posistop[®] X CLASS[™]

OIL SHEAR BRAKES

VALUE ENGINEERED FOR HIGHEST PERFORMANCE AT LOWEST COST PER CYCLE



WHERE INNOVATION NEVER RUNS DRY[™]



UNBEATABLE SAVINGS

ON WEAR AND CARE



Posistop® X Class brakes feature multi-disc brake stack with friction surfaces consisting of alternating steel plates and advanced friction material on steel discs.

- Packaged, fully assembled/tested.
- Simplified double C-face or brake motor mounting.
- Horizontal or vertical mounting.
- Spring set, air release.
- Multiple friction discs cooled in recirculating transmission fluid.
- Low maintenance: annual oil change.
- Hard-coat epoxy finish highly resistant to rust and chipping.

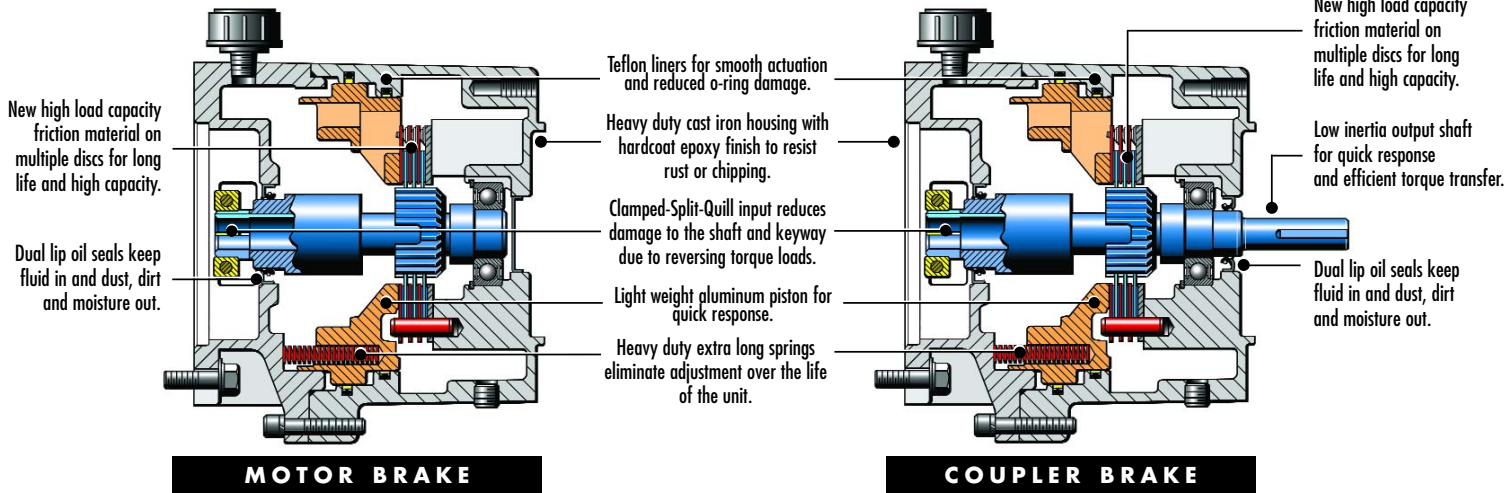

ACCESSORIES AND KITS

To make the X Class brakes adaptable to many applications, several accessories are available.

Foot Mounting Kit

For the Coupler brake a foot mounting kit is available that will bolt onto the brake for those applications where the brake may not be mounted on a C-Face motor or reducer. They are made from heavy gauge steel (XB1 & XB2), or cast iron (XB3 & XB4), and hard coat epoxy coated.

Male Input Shaft Assembly

For applications where a belt drive may be required on the input, a male input shaft assembly is available to convert the quill input to an extended shaft. It consists of a mounting plate with a bearing and stainless steel shaft that bolts to the C-Face mounting flange. The shaft is then locked into the Split Clamped Quill.

Wash Down

For wash down applications in food processing facilities, the optional wash down modification is available for both the Coupler Brake and the Motor Brake. This modification consists of nickel-plated or stainless steel shafts, stainless steel locking collar on the Clamped Split Quill, Steel It epoxy coating, stainless steel fasteners, synthetic fluid (USDA H-2) and non-corrosive breather and sight gauge.



Foot Mounting Kit

X1 & X2 Foot Kit (Pair of feet)	02-X1-FT-KIT
X1 & X2 Foot Kit Washdown (Steel It Epoxy)	02-X1-FT-KITW
X3 & X4 Foot Kit (Pair of feet)	02-X4-FT-KIT
X3 & X4 Foot Kit Washdown (Steel It Epoxy)	02-X4-FT-KITW

Extended Input Shaft Assembly

Input Shaft Ass'y. X1 5/8" shaft	02-X1-IA-KIT
Input Shaft Ass'y. X1 5/8" shaft, Washdown	02-X1-IA-KITW
Input Shaft Ass'y. X2 7/8" shaft	02-X2-IA-KIT
Input Shaft Ass'y. X2 7/8" shaft, Washdown	02-X2-IA-KITW
Input Shaft Ass'y. X3 1-1/8" shaft	02-X3-IA-KIT
Input Shaft Ass'y. X3 1-1/8" shaft, Washdown	02-X3-IA-KITW
Input Shaft Ass'y. X4 1-3/8" shaft	02-X4-IA-KIT
Input Shaft Ass'y. X4 1-3/8" shaft, Washdown	02-X4-IA-KITW

Pneumatic Control Valves* (Requires kit below)

Control Valve, 434A Series	
Manifold Mounted , 120 VAC/60Hz, 1.0 Cv	09-56-A3NN-00
Control Valve, 434A Series	
Manifold Mounted , 24 VDC, 1.0 Cv	09-56-A3NN-00
Control Valve, 35A Series, 120 VAC/60Hz, .25 Cv, ship loose	01-56-147-08
Control Valve, 35A Series, 7.3 watt 24 VDC, .21 Cv, ship loose	01-56-148-08

*Note: All valves are washdown duty, Explosion Proof available.

SIMPLIFIED C-FACE

MOUNTING SYSTEM

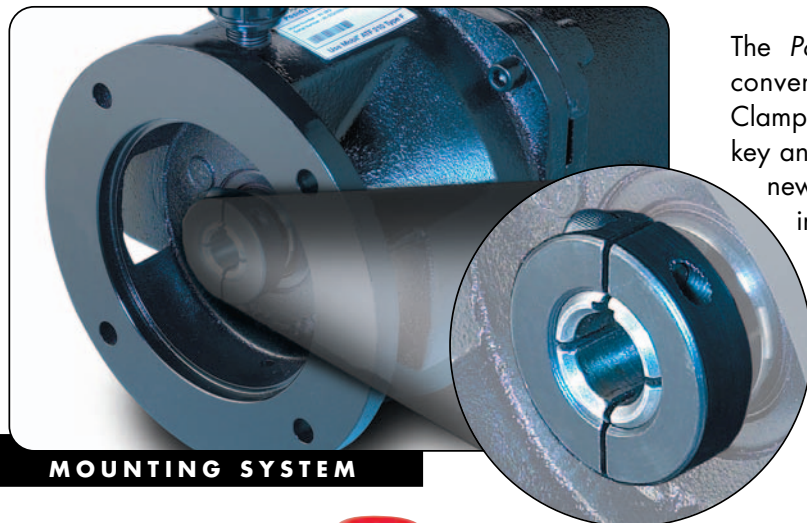

The Posistop® X Class C-face mount adds a new level of convenience to this classic configuration. An innovative Clamped-Split-Quill absolutely stops play that could deform the key and keyway in high-torque, rapid cycling applications. The new clamp design splits the input quill four ways at 90° intervals. A clamp collar fits over the quill to give 360° clamping effect when tightened down. The keyway is centered in one of the splits in the quill to securely lock the key on both sides.

MOUNTING SYSTEM

MOUNTING CONFIGURATIONS

The Posistop® X Class brakes may be mounted in three configurations (horizontal, vertical input up and vertical input down) to allow the most flexibility in machine design.

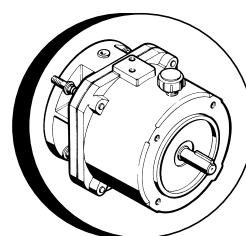

HORIZONTAL

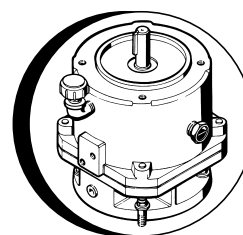

VERTICAL
INPUT-DOWN

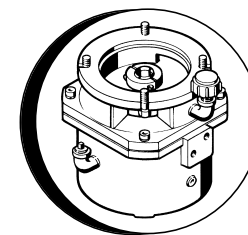

VERTICAL
INPUT-UP

SELECTION

Frame Size	56C	143TC	145TC	182TC	184TC	213TC	215TC	254TC	256TC	284TC	286TC
XB1	XB1										
XB2		XB2									
XB3				XB3							
XB4						XB4					
XB5								XB5			
XB6										XB6	

The correct size X Class brakes can be selected using motor frame size and required brake torque. The following tables indicate the proper size X Class brake based on various motor frame sizes.

Torque can be determined for moderate inertial loads using the formula
$$\text{TORQUE ft./lbs.} = \frac{\text{motor Hp} \times 5250 \times 1.5}{\text{RPM at Brake}}$$

Select a brake with a rating equal to or greater than the torque calculated.

Several torque ratings are available in each brake size. Use the following tables to select the appropriate torque.

Please contact your local distributor, rep or the factory for application assistance.

OPERATING SPECIFICATIONS

STATIC TORQUE (Lb. Ft.)

XB1	4	8	12
XB2	6	12	18

XB1 & XB2 TECHNICAL SPECIFICATIONS

	Thermal Rating (HP Sec/Min)	Max. KE per Engagement (Ft. Lbs.)	Piston Volume (Cu. In.)	Inertia WK ² (Lb. Ft. ²)	Max. Speed (RPM)	Weight (Lbs.)	Oil Capacity (Ounces)
XB1	21	578	.9	0.0130	1800	31	28
XB2	39	1075					

XB3 STATIC TORQUE (Lb. Ft.)

7	10	12
15	20	23
25	30	38

XB3 TECHNICAL SPECIFICATIONS

	Thermal Rating (HP Sec/Min)	Max. KE per Engagement (Ft. Lbs.)	Piston Volume (Cu. In.)	Inertia WK ² (Lb. Ft. ²)	Max. Speed (RPM)	Weight (Lbs.)	Oil Capacity (Ounces)
42		1712	.9	.0174	1800	45	30
				.0181			
				.0189			

XB4 STATIC TORQUE (Lb. Ft.)

12	17	24
25	36	37
50	54	75

XB4 TECHNICAL SPECIFICATIONS

	Thermal Rating (HP Sec/Min)	Max. KE per Engagement (Ft. Lbs.)	Piston Volume (Cu. In.)	Inertia WK ² (Lb. Ft. ²)	Max. Speed (RPM)	Weight (Lbs.)	Oil Capacity (Ounces)
CF	CF	CF	2.66	.0473	1800	75	60
				.0499			
				.0526			

CF= Consult Factory

XB5,6 STATIC TORQUE (Lb. Ft.)

50	65	80
100	130	150
160	185	200
240*	300**	

XB5,6 TECHNICAL SPECIFICATIONS

	Thermal Rating (HP Sec/Min)	Max. KE per Engagement (Ft. Lbs.)	Piston Volume (Cu. In.)	Inertia WK ² (Lb. Ft. ²)	Max. Speed (RPM)	Weight (Lbs.)	Oil Capacity (Ounces)
CF	CF	CF	19.5	.2011	1800	141	42
				.2215			

CF= Consult Factory

* = 1-3/8" Minimum Shaft

** = 1-5/8" Minimum Shaft

Contact Force Control for any missing specifications that were not available at printing time.

HOW TO ORDER

X	B	S	H																																																
X CLASS BRAKE	Unit SIZE (1)	SPRING SET (3)	OPTIONS (9)																																																
	<table border="0"> <tr><td>1</td><td>= SIZE 1</td></tr> <tr><td>2</td><td>= SIZE 2</td></tr> <tr><td>3</td><td>= SIZE 3</td></tr> <tr><td>4</td><td>= SIZE 4</td></tr> <tr><td>5</td><td>= SIZE 5</td></tr> <tr><td>6</td><td>= SIZE 6</td></tr> </table>	1	= SIZE 1	2	= SIZE 2	3	= SIZE 3	4	= SIZE 4	5	= SIZE 5	6	= SIZE 6	TORQUE (5,6,7) Lb. Ft. example: 6 Lb. - Ft. = 006 12 Lb. - Ft. = 012	<table border="0"> <tr><td>H</td><td>= Horizontal</td></tr> <tr><td>V</td><td>= Vertical Up, Brake above motor</td></tr> <tr><td>D</td><td>= Vertical Down, Brake below motor</td></tr> </table>	H	= Horizontal	V	= Vertical Up, Brake above motor	D	= Vertical Down, Brake below motor																														
1	= SIZE 1																																																		
2	= SIZE 2																																																		
3	= SIZE 3																																																		
4	= SIZE 4																																																		
5	= SIZE 5																																																		
6	= SIZE 6																																																		
H	= Horizontal																																																		
V	= Vertical Up, Brake above motor																																																		
D	= Vertical Down, Brake below motor																																																		
INPUT MODULE (2) Frame Size		OUTPUT MODULE (4)	PACKAGE TYPE (8)																																																
<table border="0"> <tr><td>2</td><td>= 5/8"U 4-1/2"AK</td><td>56</td></tr> <tr><td>3</td><td>= 7/8"U 4-1/2"AK</td><td>143/145</td></tr> <tr><td>4</td><td>= 1-1/8"U 8-1/2"AK</td><td>182/184</td></tr> <tr><td>5</td><td>= 1-3/8"U 8-1/2"AK</td><td>213/215</td></tr> <tr><td>6</td><td>= 1-5/8"U 8-1/2"AK</td><td>254/256</td></tr> <tr><td>7</td><td>= 1-5/8"U 10-1/2"AK</td><td>284/286</td></tr> <tr><td>8</td><td>= 1-7/8"U 10-1/2"AK</td><td></td></tr> </table>	2	= 5/8"U 4-1/2"AK	56	3	= 7/8"U 4-1/2"AK	143/145	4	= 1-1/8"U 8-1/2"AK	182/184	5	= 1-3/8"U 8-1/2"AK	213/215	6	= 1-5/8"U 8-1/2"AK	254/256	7	= 1-5/8"U 10-1/2"AK	284/286	8	= 1-7/8"U 10-1/2"AK			<table border="0"> <tr><td>0</td><td>= MOTOR BRAKE</td></tr> <tr><td>2</td><td>= 5/8"U, 4-1/2"AK</td><td>56</td></tr> <tr><td>3</td><td>= 7/8"U, 4-1/2"AK</td><td>143/145</td></tr> <tr><td>4</td><td>= 1-1/8"U, 8-1/2"AK</td><td>182/184</td></tr> <tr><td>5</td><td>= 1-3/8"U, 8-1/2"AK</td><td>213/215</td></tr> <tr><td>6</td><td>= 1-5/8"U, 8-1/2"AK</td><td>254/256</td></tr> <tr><td>7</td><td>= 1-5/8"U, 10-1/2"AK</td><td>284/286</td></tr> <tr><td>8</td><td>= 1-7/8"U, 10-1/2"</td><td></td></tr> </table>	0	= MOTOR BRAKE	2	= 5/8"U, 4-1/2"AK	56	3	= 7/8"U, 4-1/2"AK	143/145	4	= 1-1/8"U, 8-1/2"AK	182/184	5	= 1-3/8"U, 8-1/2"AK	213/215	6	= 1-5/8"U, 8-1/2"AK	254/256	7	= 1-5/8"U, 10-1/2"AK	284/286	8	= 1-7/8"U, 10-1/2"		<table border="0"> <tr><td>S</td><td>= Standard</td></tr> <tr><td>W</td><td>= Washdown</td></tr> </table> <p>Washdown includes Steelit epoxy coating, SS Fasteners, nickel plated shafts.</p>	S	= Standard	W	= Washdown
2	= 5/8"U 4-1/2"AK	56																																																	
3	= 7/8"U 4-1/2"AK	143/145																																																	
4	= 1-1/8"U 8-1/2"AK	182/184																																																	
5	= 1-3/8"U 8-1/2"AK	213/215																																																	
6	= 1-5/8"U 8-1/2"AK	254/256																																																	
7	= 1-5/8"U 10-1/2"AK	284/286																																																	
8	= 1-7/8"U 10-1/2"AK																																																		
0	= MOTOR BRAKE																																																		
2	= 5/8"U, 4-1/2"AK	56																																																	
3	= 7/8"U, 4-1/2"AK	143/145																																																	
4	= 1-1/8"U, 8-1/2"AK	182/184																																																	
5	= 1-3/8"U, 8-1/2"AK	213/215																																																	
6	= 1-5/8"U, 8-1/2"AK	254/256																																																	
7	= 1-5/8"U, 10-1/2"AK	284/286																																																	
8	= 1-7/8"U, 10-1/2"																																																		
S	= Standard																																																		
W	= Washdown																																																		
		Frame Size	COUPLER BRAKE																																																
			Contact Force Control for Technical Specifications not given.																																																

Posistop® X CLASS



BRAKES

X-TREME PERFORMANCE – NOW VALUE-ENGINEERED FOR 1/2 TO 10 HP DRIVES



MOTOR BRAKE

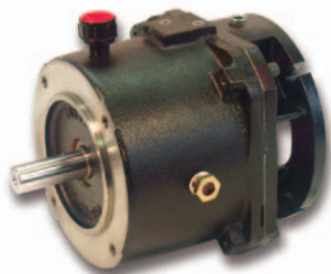

COUPLER BRAKE

New Posistop® X Class brakes let you eliminate the typical line stops, the frequent brake repairs and replacements. Here's the reliability you need for today's 24/7 manufacturing demands. Here's speed and precision that can let you run at higher cycle rates and quality levels, or design new machines for higher performance.

Value engineering gives you X times the performance possible from conventional dry brakes:

- 10X longer design life – designed for over 6 million cycles.
- Clamped-Split-Quill reduces keyway problems in aggressive applications.

MORE NUMBERS YOU'LL LIKE:

- Up to 50% lower cost per index than disposable dry brakes.
- Up to 88% lower internal inertia delivers ultra-quick acceleration and reduced power consumption.

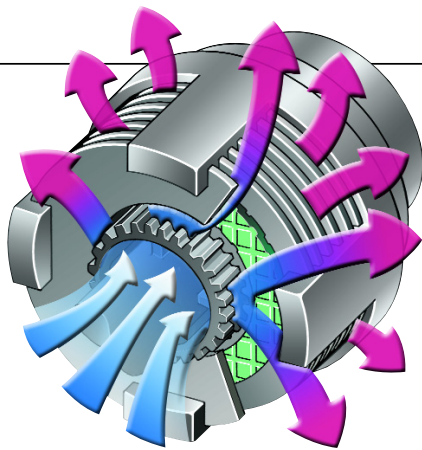

FLUID FLOW

Posistop® X Class brakes transmit torque by shearing automatic transmission fluid between multiple friction discs.

The fluid absorbs the heat of engagement and dissipates it through the housing. The recirculating fluid minimizes wear,

resulting in exceptional service life, up to

10 times longer than conventional dry brakes.

THE OIL-SHEAR

DIFFERENCE

No ordinary brakes, Posistop® X Class units use proprietary oil-shear technology perfected over more than 30 years by Force Control Industries. Posistop® X Class brake units have proven themselves in the toughest production environments, including automotive, lumber, building materials, packaging, warehousing, and food processing – where there is absolutely no time for downtime.

With the X Class, Force Control transforms oil-shear technology into affordable, off-the-shelf designs. Six standard models – XB1, XB2, XB3, XB4, XB5 and XB6, mostly stocked, cover the most popular size ranges for brakes. Convenient double C-face or motor brake mounting and handy Clamped-Split-Quill allow drop-in, bolt-up installation.

DIMENSIONS

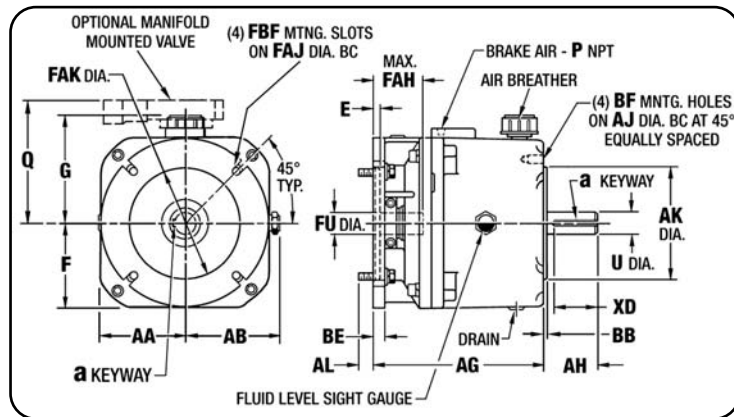

COUPLER BRAKE DIMENSIONS

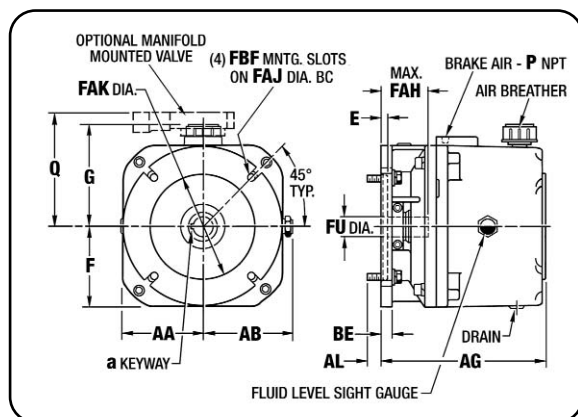

MOTOR BRAKE DIMENSIONS

Dimensions are subject to change without notice.
Certified Installation Drawings are available upon request.

BRAKE SIZE	OVERALL DIMENSIONS (Inches)						
	AA	AB	AG	F	G	P	Q
XB1	3.51	3.77	7.00	3.44	4.50	1/8 NPT	4.94
XB2	4.44	4.44	8.46	4.44	5.08		
XB4	4.50	5.00	CF	4.50	5.67	1/4 NPT	6.00
XB5/6	5.50	5.50	11.45	5.50	6.64	1/4 NPT	CF

BRAKE SIZE	INPUT DIMENSIONS (Inches)							
	AL	BE	E	FAH	FAJ	FAK	FU	FBF
XB1	.63	.50	.28	2.38	5.88	4.502	5/8	7/16 SLOT
XB2						4.500	7/8	
XB3	.57	.73	.19	2.94	7.25	8.502	7/8	9/16 SLOT
XB4	.75	.83		3.13		8.500	1-1/8	
XB5	.71	.69	N/A	2.88	7.25	N/A	1-1/8	17/32 SLOT
XB6				4.88			1-3/8	
				4.72	9.00		1-5/8	
							1-7/8	

BRAKE SIZE	OUTPUT DIMENSIONS (Inches)							
	a	AH	AJ	AK	BB	BF	U	XD
XB1	3/16	2.06	5.875	4.500	.16	3/8-16	5/8	1.50
XB2	x 3/32	2.12		4.498				
XB3	1/4	2.63	7.250	8.500	.25	1/2-13	1-1/8	2.00
XB4	x 1/8	3.13					8.498	1-3/8
XB5	5/16	2.75	7.25	8.500	.25	1/2-13	1-1/8	2.65
	x 5/32	3.37					8.498	1-3/8
		4.00					1-5/8	3.63
XB6	3/8	4.63	9.00	10.500			1-5/8	3.69
	1/2	4.38		10.498			1-7/8	3.62

CF = CONSULT FACTORY

DIMENSIONS (COUPLER BRAKE WITH MOUNTING FEET AND MALE INPUT SHAFT)

XB1 & XB2 Posistop X Class Brakes

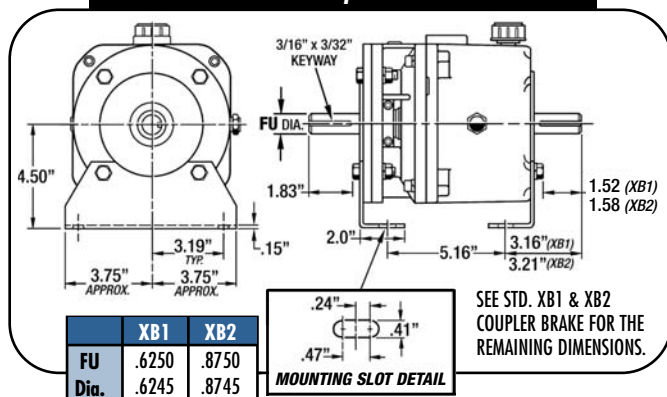

SEE STD. XB1 & XB2 COUPLER BRAKE FOR THE REMAINING DIMENSIONS.

XB3 & XB4 Posistop X Class Brakes

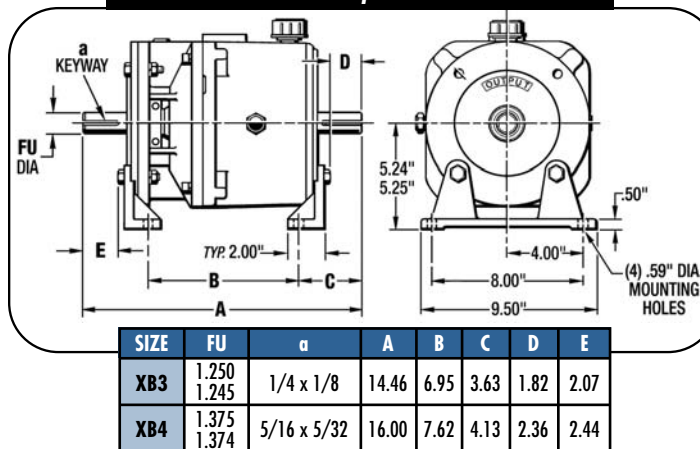

SEE STD. XB3 & XB4 COUPLER BRAKE FOR THE REMAINING DIMENSIONS.

Force Control Industries, Inc.
Headquarters & Plant
3660 Dixie Highway
Fairfield, Ohio 45014
Phone: 513-868-0900
Fax: 513-868-2105

email: xclass@forcecontrol.com
www.forcecontrol.com



WHERE INNOVATION NEVER RUNS DRY™



Made in USA

© 2003 Force Control Industries, Inc.
Printed in the U.S.A.
catalog xclass-09-03-AP25m