



Posistop Motor Brake Specifications

The Posistop Motor Brakes (MB Series) with multiple springs and multiple discs are very flexible brakes. They may be assembled to obtain a broad range of torque ratings. The spring set torque of the brake is determined by the number of springs and number of discs assembled. The following charts show all of the options however the ones in bold type are considered standard. Typically selecting the maximum number of discs and fewer springs to achieve the desired torque is ideal.

MB-056 Specifications

Discs	No. Springs			
	2	3	4	6
	Torque Static (Dynamic)			
1	2	3	4	6
2	2	6	8	12
3	6	9	12	18
	Pressure to Release (PSI)			
	20	30	40	60

Thermal Rating (Hp Sec/Min)	Max. KE per Engage ment (Ft. Lbs)	Piston Volume (Cu In)	Inertia WK2 (Lb. Ft. ^2)	Max. Speed (RPM)	Weight (Lbs.)	Oil Capacity (Ounces)
30	4650	0.5	0.009	1800		

MB-180, MB-210, MB-210L Specifications

Discs	No. Springs			
	2	3	4	6
	Torque Static (Dynamic)			
1	10	15	20	30
2	20	30	40	60
3	30	45	*60	*90
	Pressure to Release (PSI)			
	20	28	35	51

Thermal Rating (Hp Sec/Min)	Max. KE per Engage ment (Ft. Lbs)	Piston Volume (Cu In)	Inertia WK2 (Lb. Ft. ^2)	Max. Speed (RPM)	Weight (Lbs.)	Oil Capacity (Ounces)
25	6425	3	0.034	3600		

* Torque not available with 7/8" dia. collet

MB-250 and MB-280 Specifications

Discs	No. Springs			
	2	4	6	8
	Torque Static (Dynamic)			
1	15	30	45	60
2	30	60	90	120
3	45	90	135	180
4	60	120	180	*240
5	75	150	225	*300
	Pressure to Release (PSI)			
	20	28	35	51

Thermal Rating (Hp Sec/Min)	Max. KE per Engage ment (Ft. Lbs)	Piston Volume (Cu In)	Inertia WK2 (Lb. Ft. ^2)	Max. Speed (RPM)	Weight (Lbs.)	Oil Capacity (Ounces)
50	18500	5	0.215	1800		

* Torque not available with 1 1/8" or 1 3/8" dia. collet



Posistop Motor Brake Specifications (Cont.)

MB-320 Specifications

Discs	No. Springs			
	3	4	6	9
	Torque Static (Dynamic)			
1	30	40	60	90
2	60	80	120	180
3	90	120	180	270
4	120	160	*240	*360
5	150	200	*300	[△] 450
	Pressure to Release (PSI)			
	20	28	35	51

Thermal Rating (Hp Sec/Min)	Max. KE per Engage ment (Ft. Lbs)	Piston Volume (Cu In)	Inertia WK2 (Lb. Ft.^2)	Max. Speed (RPM)	Weight (Lbs.)	Oil Capacity (Ounces)
70	18500	6	0.215	1800		

* Minimum shaft diameter 1 5/8"

△ Minimum shaft diameter 1 7/8"

MB-440 Specifications

Discs	No. Springs			
	6	8	10	12
	Torque Static (Dynamic)			
4	440	590	750	900
9	990	1340	1690	2030
	Pressure to Release (PSI)			
	20	30	40	60

Thermal Rating (Hp Sec/Min)	Max. KE per Engage ment (Ft. Lbs)	Piston Volume (Cu In)	Inertia WK2 (Lb. Ft.^2)	Max. Speed (RPM)	Weight (Lbs.)	Oil Capacity (Ounces)
C/F	C/F	47.4	2.1	1800		

NOTE: Maximum speed—1800 RPM except sizes MB-180 and MB210 which is 3600 RPM in horizontal and vertical down position.

CF—Consult factory



Posistop Motor Brake Dimensions (Inches)

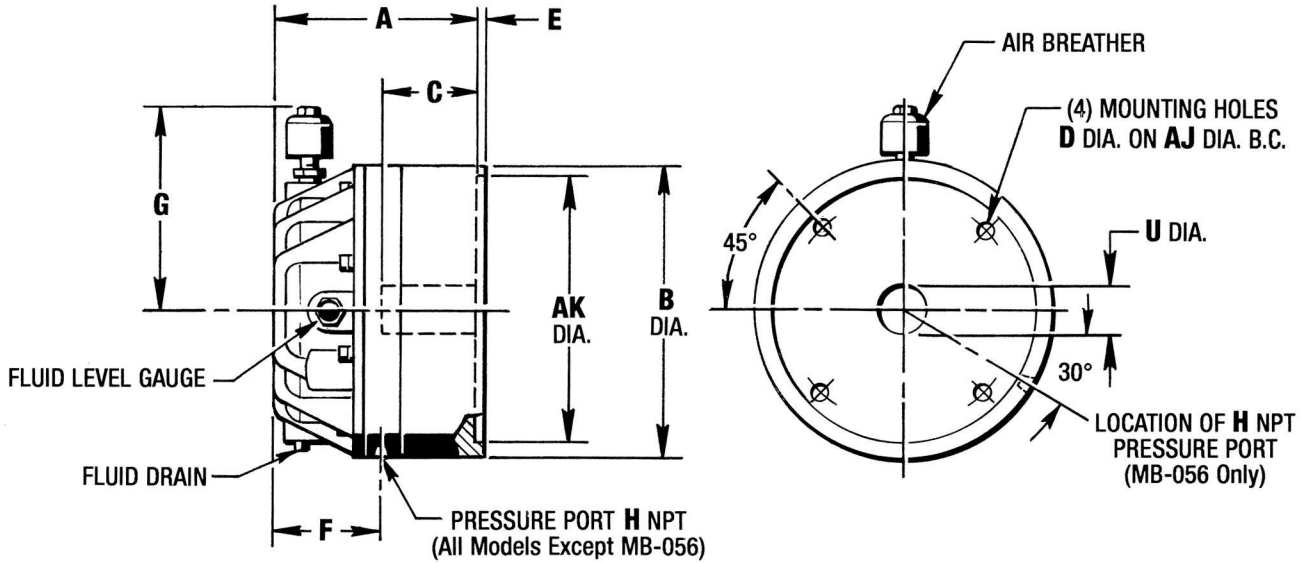

Brake Size	Dimensions (Inches)											Fluid Capacity	Weight Lbs.	
	A	B	C		D Dia.	E	F	G	H NPT	U* Dia.	AJ Dia.			AK Dia.
			Min.	Max.										
MB-056	4.81	6.63	1.38	2.13	0.41	0.25	1.88	4.63	1/8"	0.625	5.88	4.50	6 oz.	15
MB-180	6.13	8.81	1.75	2.75			3.38	5.75		0.875				
MB-210	6.13	8.81	1.75	2.62	0.53	0.19	3.38	5.75	1/8"	0.875	7.25	8.50	1 Qt.	45
MB-210L	6.88		2.50	3.50						1.125				
MB-250	10	10.88	2.00	4.13	0.53	0.19	5.38	6.25	1/4"	1.125	7.25	8.50	2 QT.	100
MB-280							5.44			1.375				
MB-320	10.63	12.88	2.50	4.63	0.66	0.19	6.06	7.25	1/4"	1.375	11.00	12.50	5 Qt.	160
MB-440	17.61	16.75	4.00	5.00	0.66	0.22	4.54	9.76	3/4"	2.125	14.00	16.00	5.5 Qt.	370
										2.375				
										2.875				
										3.375				

Consult Factory for non-standard bore sizes and thru-shaft configurations.



How To Order Posistop Motor Brake

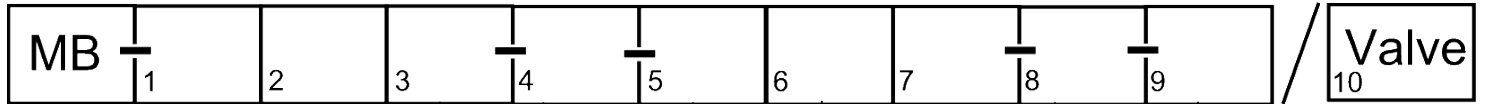

(1, 2 & 3) Model

056	= 56
180	= 180
210	= 210
21L	= 210L
250	= 250
280	= 280
320	= 320
440	= 440

(5, 6 & 7) Static Torque (Lb. Ft.)

002	= 2	135	= 135
003	= 3	150	= 150
004	= 4	160	= 160
006	= 6	180	= 180
008	= 8	200	= 200
009	= 9	225	= 225
010	= 10	240	= 240
012	= 12	270	= 270
015	= 15	300	= 300
018	= 18	360	= 360
020	= 20	440	= 440
030	= 30	450	= 450
040	= 40	590	= 590
045	= 45	750	= 750
060	= 60	900	= 900
075	= 75	990	= 990
080	= 80	D40	= 1340
090	= 90	G90	= 1690
120	= 120	L30	= 2030

(8) Shaft Diameter

A	= 5/8"
0	= 7/8"
1	= 1 1/8"
2	= 1 1/4"
3	= 1 3/8"
5	= 1 5/8"
7	= 1 7/8"
C	= 2 1/8"
D	= 2 1/4"
E	= 2 3/8"
J	= 71/80*
K	= 90/100*
L	= 112/132s*
M	= 132M/160M*
N	= 160L/225*

* SEW Eurodrive metric frame motors.

See Valves for valve specifications and ordering number. If no valve is needed use "N".

(4) Mounting

Horizontal	
S	= Std.
T	= Thru Shaft
Vertical	
1	= Std. Brake Up
2	= Std. Brake Down
3	= Thru Shaft Brake Up
4	= Thru Shaft Brake Down

(9) Encoder/Tachometer

E	= Encoder
T	= Tachometer
N	= None

Posistop Mounting Options

	056	180	210	210L	250	280	320	440
S	X	X	X	X	X	X	X	X
T		X	X	X	X	X	X	X
1	X	X	X	X	X	X	X	X
2	X	X	X	X	X	X	X	X
3		X	X	X	X	X	X	X
4		X	X	X	X	X	X	X

Posistop Shaft Diameter Options

FU	056	180	210	210L	250	280	320	440
5/8"	X ¹							
7/8"	X ¹	X ³	X ³	X ³				
1 1/8"		X	X	X	X	X		
1 3/8"		X ²	X ²	X ²	X	X	X	
1 5/8"					X ²	X ²	X	
1 7/8"					X ²	X ²	X	
2 1/8"								X ²
2 3/8"								X ²

- NOTES
1. Not available with thru-shaft configuration
 2. Consult factory for thru-shaft configuration
 3. Must be 45 Lb. Ft. or less

Horizontal/Vertical Mounting

The illustrations below indicate when it is necessary to select vertical mounting based on the angle of installation.

