

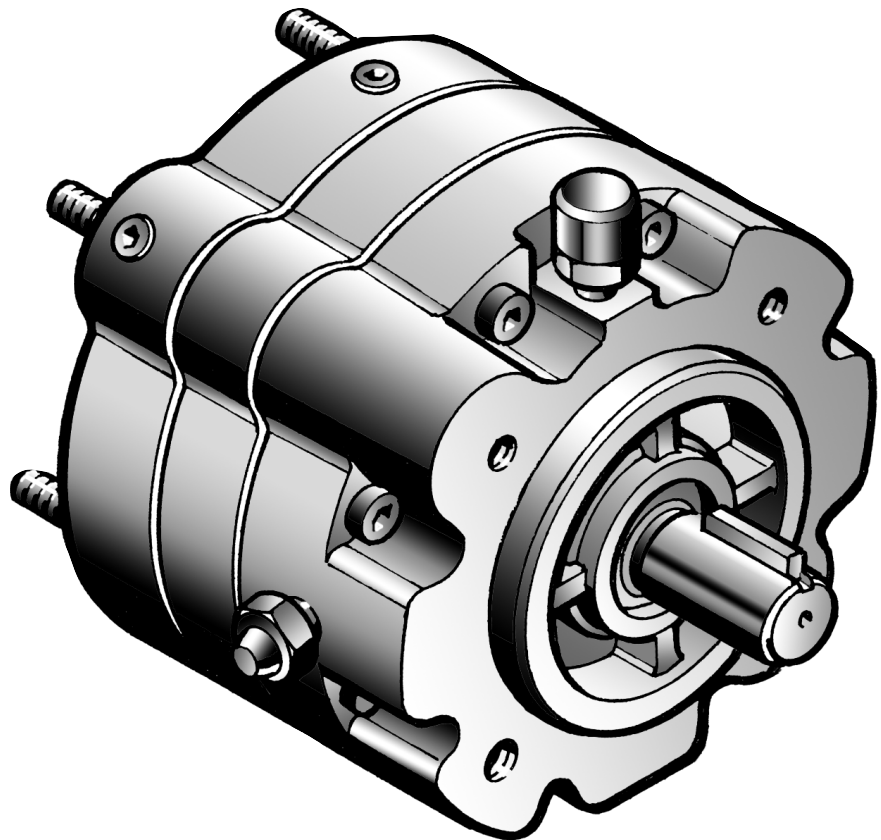

502-CB-056-02

SERVICE MANUAL AND REPAIR PARTS FOR *Posistop*[®] MB-056 COUPLER BRAKE



WARNING - Read this manual before any installation, maintenance or operation.



FORCE CONTROL INDUSTRIES, INC.

**MANUFACTURERS OF MECHANICAL AND
ELECTRICAL POWER TRANSMISSION EQUIPMENT**

Limited Warranty

Force Control Industries, Inc. ("Force Control") warrants its products to be free from defects in material and workmanship under normal and proper use for a period of one year from the date of shipment. Any products purchased from Force Control that upon inspection at Force Control's factory prove to be defective as a result of normal use during the one year period will be repaired or replaced (at Force Controls' option) without any charge for parts or labor. This limited warranty shall be void in regard to (1) any product or part thereof which has been altered or repaired by a buyer without Force Control's previous written consent or (2) any product or part thereof that has been subjected to unusual electrical, physical or mechanical stress, or upon which the original identification marks have been removed or altered. Transportation charges for shipping any product or part thereof that the buyer claims is covered by this limited warranty shall be paid by the buyer. If Force Control determines that any product or part thereof should be repaired or replaced under the terms of this limited warranty it will pay for shipping the repaired or replaced product or part thereof back to the buyer. EXCEPT FOR THE EXPRESS WARRANTY SET OUT ABOVE, FORCE CONTROL DOES NOT GRANT ANY WARRANTIES EITHER EXPRESSED OR IMPLIED, INCLUDING IMPLIED WARRANTIES OF MERCHANTABILITY OR FITNESS FOR USE. The warranty obligation set forth above is in lieu of all obligations or liabilities of Force Control for any damages. Force Control specifically shall not be liable for any costs incurred by the buyer in disconnecting or re-installing any product or part thereof repaired or replace under the limited warranty set out above. FORCE CONTROL EXPRESSLY EXCLUDES ALL LIABILITY FOR ANY INDIRECT OR CONSEQUENTIAL DAMAGES THE BUYER MAY SUSTAIN IN CONNECTION WITH THE DELIVERY, USE, OR PERFORMANCE OF FORCE CONTROL PRODUCTS. Under no circumstances shall any liability for which Force Control is held responsible exceed the selling price to the buyer of the Force Control products that are proven to be defective. This limited warranty may be modified only in writing signed by a duly authorized officer of the company. This limited warranty applies exclusively to Force Control products; warranties for motors and gear reducers and other component parts may be provided by their respective manufactures. Any legal action for breach of any Force Control warranty must be commenced within one year of the date on which the breach is or should have been discovered.

A Return Goods Authorization (RGA) number must be obtained from the factory and clearly marked on the outside of the package before any equipment will be accepted for warranty work. Force Control will pay the shipping costs of returning the owner parts that are covered by warranty.

Force Control believes that the information in this document is accurate. The document has been carefully reviewed for technical accuracy. In the event that technical or typographical errors exist, Force Control reserves the right to make changes to subsequent editions of this document without prior notice to holders of this edition. The reader should consult Force Control if errors are suspected. In no event shall Force Control be liable for any damages arising out of or related to this document or the information contained in it.



Table of Contents

Posistop MB-056 Coupler Brake

Section 1 - DESCRIPTION AND OPERATION

1-1 The Oil Shear Principle	1
1-2 Typical Applications	1
1-3 Description	1
1-4 Features and Benefits	2
1-5 Coupler Brake Operation	2

Section 2 - SPECIFICATIONS

2-1 Dimensional Specifications	3
2-2 Operating Specifications	3
2-3 Stack Configurations	4

Section 3 - INSTALLATION

3-1 Receiving the Brake Unit	4
3-2 Verifying Motor Specifications	4
3-3 Mounting the Brake	5
3-4 Mounting Motor and Brake to Gear Reducer .	6
3-5 Pneumatic Control Valve Hook-Up	6
3-6 Vertical Vs. Horizontal Installation	6

Section 4 - LUBRICATION

4-1 Checking the Oil Level	7
4-2 Changing the Oil	
A. Horizontal Brake	7
B. Vertical Up Brake	7
C. Vertical Down Brake	7
4-3 Type of Oil	8

Section 5 - OPERATIONAL CHECKS

5-1 Operational Checks	8
------------------------------	---

Section 6 - TROUBLESHOOTING

6-1 Troubleshooting Chart	9
6-2 Measuring Brake Stack Height	10

Section 7 - DISASSEMBLY

7-1 Removing Coupler Brake and Drive Motor from Gear Reducer	10
7-2 Removing End Housing (#9) For Access to the Brake Stack	11
7-3 Removing Hub (#2)	11

7-4 Hub (#2) Disassembly	
A. Removing Wear Sleeve (#32)	12
B. Removing Bearing (#20)	12
7-5 Removing Plston Housing (#10) and Piston (#3) to Replace Piston Seals	12
7-5 Removing Oil Seals	
A. Oil Seal (#31)	13
B. Oil Seal (#35)	13

Section 8 - CLEANING AND INSPECTION

8-1 Cleaning and Inspection	13
8-2 Repair and Replacement	13

Section 9 - REASSEMBLY

9-1 General Reassembly Instructions	14
9-2 Installing Oil Seals	14
9-3 Installing Housing (#8) to Drive Motor	14
9-4 Piston (#3) and Piston Housing (#10) Reassembly	15
9-5 Hub (#2) Reassembly	
A. Installing Wear Sleeve (#32)	15
B. Installing Bearing (#20)	15
9-6 Installing Hub (#2) into Brake	16
9-7 Replacing the Brake Stack	
A. Full Brake Stack	16
B. Short Brake Stack	17
9-8 Installing End Housing (#9)	17
9-9 Final Reassembly	17

Section 10 - ORDERING REPLACEMENT PARTS

10-1 General Information	18
10-2 Factory Rebuild Service	18
10-3 Ordering Replacement Parts	18
10-4 Name Plate Information	18
Model Number Information	19
Figure 10.1 - Short Brake Stack	20
Figure 10.2 - <i>Posistop</i> MB-056 Coupler Brake ...	21
Figure 10.3 - Vertical Installation	23
Figure 10.3 - Pneumatic Control Valve Mounting Kit	23

Section 1

DESCRIPTION AND OPERATION

1-1 THE OIL SHEAR PRINCIPLE

Conventional clutches and brakes depend on the friction between solid surfaces operating in air to transmit torque. Friction does the job, but produces a great amount of Heat and Wear, causing an increase in replacement parts, breakdown and maintenance time.

OIL SHEAR TECHNOLOGY was pioneered by **Force Control Industries, Inc.** in 1959 and resulted in one of the most energy efficient Clutch/Brake or Variable Drive Systems available today.

In 1970 **Force Control** introduced an **integral oil pump**, which requires no additional parts. This oil pump forces a positive oil feed from the center of the brake disc stack to “**Float**” the friction surfaces in a continuously circulating bath of oil.

The oil molecules tend to cling to each other and also to the friction surfaces. As moving and stationary parts are brought together, a thin but positive film of oil is maintained between them and is controlled by the clamping pressure and grooves machined into the braking surfaces.

Torque is transmitted from one surface to the other through the viscous shear of the oil film. The braking surfaces are protected by this oil film, which reduces wear and effectively transmits heat away from the braking surfaces.

...thus brake wear is greatly reduced along with all routine maintenance common to conventional dry friction motor brakes.

AN OIL CHANGE EVERY 6 MONTHS IS ALL THAT IS REQUIRED FOR NORMAL MAINTENANCE.

1-2 TYPICAL APPLICATIONS

(See Figure 1.1)

The **Posistop MB-056 Coupler Brake** can be applied where cycle rates are too low to justify a Clutch/Brake (roughly less than 10 CPM), or in applications where the motor must reverse. Common applications include Palletizers (apron or slip plate, flight or push bar, roller bed conveyor), Indexing Conveyors,

Shrink Wrappers, Package Handling Equipment, General Material Handling Equipment and Tire Manufacturing Equipment.

Typical Drive Assembly is shown in Figure 1.1.

1-3 DESCRIPTION

(See Figure 1.2 on next page.)

The **Posistop MB-056 Coupler Brake** is a compact motor brake that transmits torque by shearing fluid between multiple friction surfaces. The fluid cools and constantly lubricates the friction surfaces for improved performance and longer service life. It also reduces engagement shock that results when dry friction brakes are used.

This brake is designed for indexing applications utilizing a standard NEMA C-Face register on both ends which allows the brake to be mounted between a C-Face Drive Motor and a C-Face Speed Reducer.

A complete package can be furnished including the Drive Motor, Coupler Brake and Speed Reducer. Contact Force Control for selecting the proper size components for long life cycling applications.

The multiple brake disc stack delivers high torque in a low inertia package. The **MB-056 Coupler Brake** is rated at a maximum of 18 Ft. Lbs. of torque.

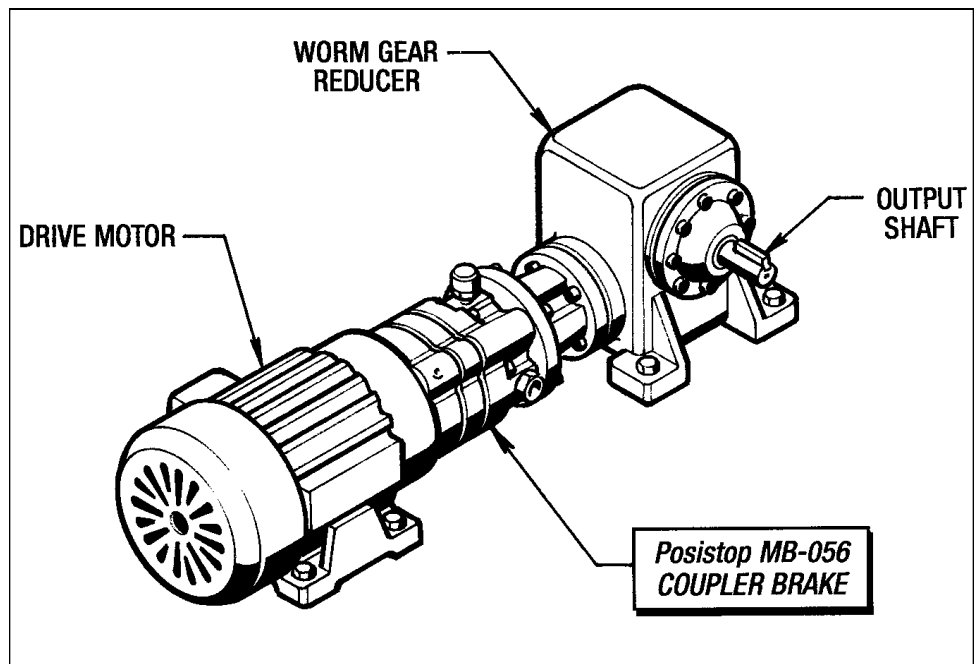

Figure 1.1 - Typical Drive Assembly

1-4 FEATURES AND BENEFITS

The most important Feature and Benefit is the fact that it will reduce maintenance time and provide a very long service life.

- Low inertia, multiple disc oil shear brake for long life, high cycle rates and high thermal loads
- Keyless Collet is a positive self-locking element with high torque transmitting capabilities. Standard size is 7/8" Diameter.
- Totally enclosed design prevents contamination and corrosion.
- Spring set brake with air release. (Automatic braking if electrical or pneumatic power is interrupted.)
- The complete brake only weighs 19 pounds.
- Standard NEMA C-Face mounting. AC or DC motor connections for 56C, 143TC, 145TC, 182C and 184C frame motors.
- Multiple surface brake stack distributes the braking torque along the whole hub rather than on a single braking surface, reducing the heat and wear on each braking surface.

- Internal integral oil pump maintains the *Oil Shear Principle* without external pumping devices.
- 4.5 Ft. Lbs. to 18 Ft. Lbs. braking torque. (Contact Force Control for other torque requirements.)
- Vertical up, vertical down and horizontal mounting.
- Standard output shaft is 7/8" diameter.
- Applications for customer's output shaft include coupled or quill connections.

1-5 COUPLER BRAKE OPERATION

The Cross Section in Figure 1.3 shows the brake in the normally spring-set braked position.

To run - The Control Valve Solenoid is energized which directs compressed air into the piston chamber which moves the piston to disengage the brake stack, allowing the drive motor to rotate freely.

To Stop - The Control Valve Solenoid is de-energized which exhausts the air from the piston chamber. The Piston, which is spring loaded, returns to the braking position and stops the drive motor.

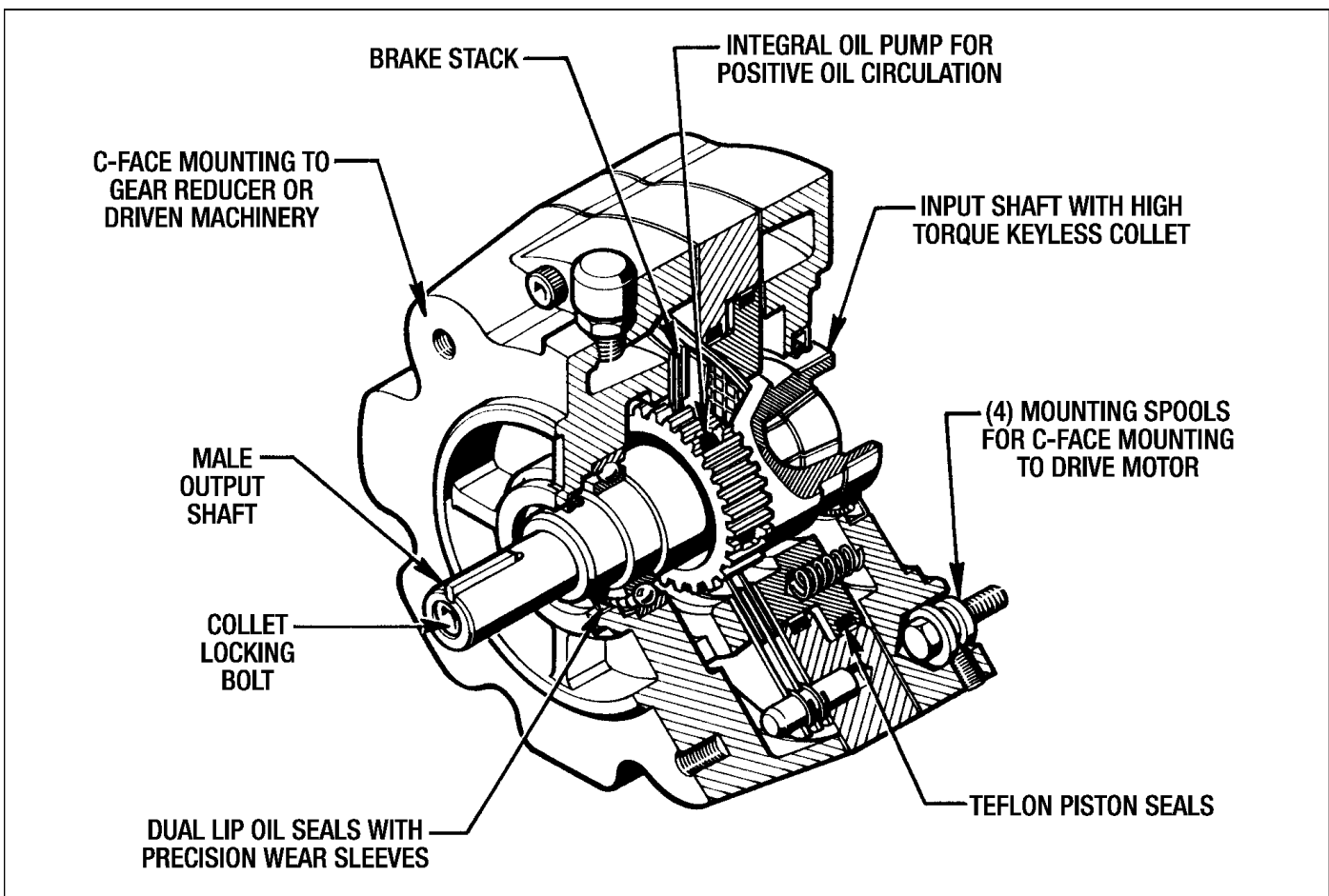

Figure 1.2 - Posistop MB-056 Coupler Brake Description and Features

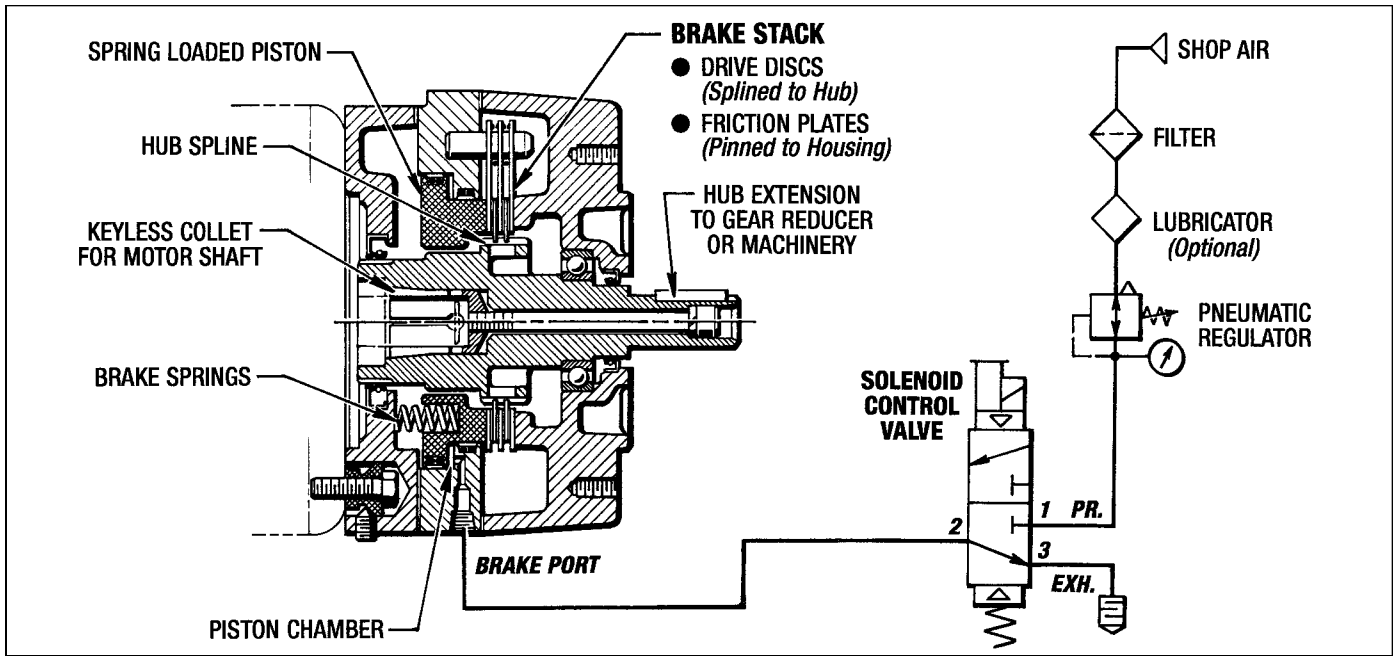
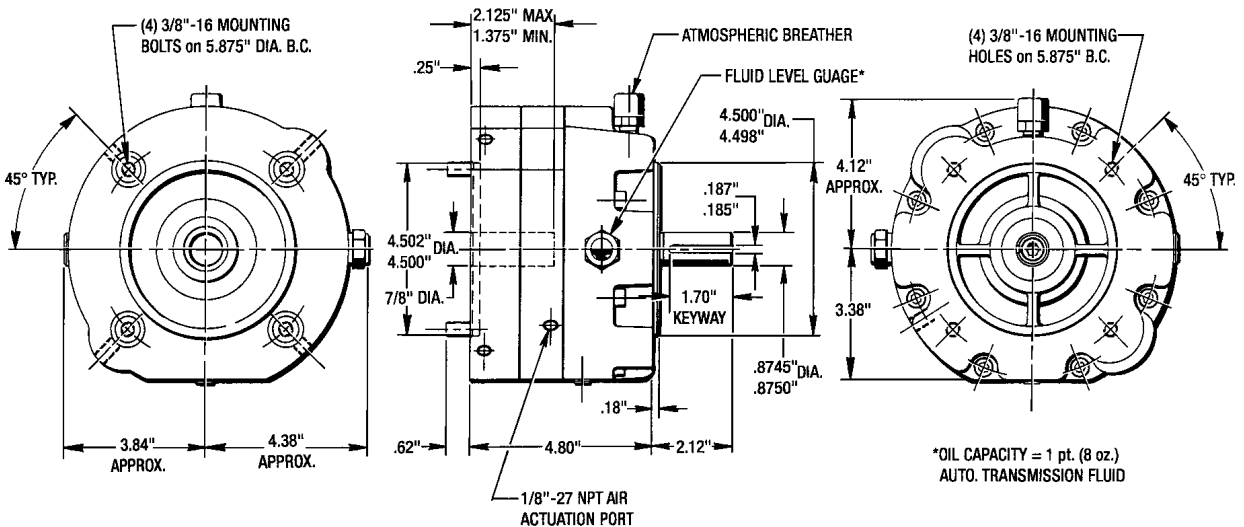

Figure 1.3 - MB-056 Coupler Brake Operation

Section 2 SPECIFICATIONS

2-1 DIMENSIONAL SPECIFICATIONS



2-2 OPERATING SPECIFICATIONS

Static Torque (Lb. Ft.)	Dynamic Torque (Lb. Ft.)	Thermal Rating <i>HP Sec. Minute</i>	Max. KE per Engmt. w / Full Stack (Lb. Ft.)	Inertia WK^2 (Lb. Ft. ²)	Piston Volume (Cu. In.)	Fluid Capacity (Pints)	Weight (Lbs.)
4.5	3.9	30	4650	.009	1	1	19
6	5.2						
9	7.7						
12	10.3						
18	15.5						

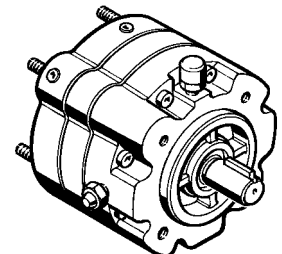

2-3 STACK CONFIGURATIONS

Short Stack

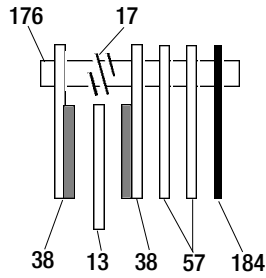

Torque (Ft. Lbs.)	Spring (#36) Qty.	PSI to Release	
		Min.	Max.
4.5	3	15	30
6	4	20	40
9	6	30	60

Full Stack

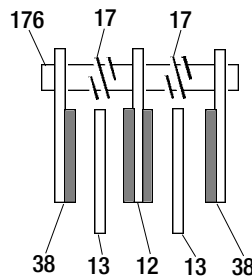

Torque (Ft. Lbs.)	Spring (#36) Qty.	PSI to Release	
		Min.	Max.
9	3	15	30
12	4	20	40
18	6	30	60

Brake Stack Parts Description:

- #12 - Double Sided Friction Plate. (Pinned to Housing.)
- #13 - Drive Disc. (Splined to Hub.)
- #17 - Separator Springs.
- #38 - Single Sided Friction Plate. (Pinned to Housing.)
- #57 - Filler Plate (Pinned to Housing.)
- #176 - Dowel Pins.
- #184 - Shim. (Pinned to Housing.)

Section 3 INSTALLATION

IMPORTANT SAFETY PRECAUTIONS

The brake units described in this manual must not be installed in any manner except as specified herein and must not be operated at speeds, torque loads or temperatures other than what is specified in this manual. Failure to limit the operation of the brakes to the conditions specified could damage the brake units and may cause mal-function or damage to inter-connecting equipment

WARNING

The following precautions must be taken if the installation is to be a retrofit for an existing application. Before attempting installation, open the motor disconnects, shut off the control electrical supply and shut off the air supply. Lock them out to avoid the possibility of any personal injury.

3-1 RECEIVING THE BRAKE UNIT

Check the Brake for shortages and damages immediately after arrival. Prompt reporting to the Carrier's Agent, with notations made on the Freight Bill, will expedite any adjustment made by the carrier.

The *Posistop MB-056 Coupler Brake* is shipped pre-assembled except for the (4) Mounting Spools (#109) and the (4) Hex Hd. Mounting Screws (#150). The Key (#180) is also shipped loose.

The brake is also shipped with a *Shipping Sleeve* in the Collet (#110). This *Shipping Sleeve* is just a piece of PVC tubing or conduit cut to length and inserted into the Collet (#110) so the Hub (#2) will not drop and damage

the Oil Seals (#31) and (#35) in shipping. **Remove this Shipping Sleeve before Installation.**

The Brake is also shipped dry so the fluid will have to be added after it is installed as per instructions given in **Section 4 - Lubrication.**

If the Brake is not to be installed or operated soon after arrival, then store it in a clean dry place that has a slow and moderate change in ambient temperature.

3-2 VERIFYING MOTOR SPECIFICATIONS

The Motor Manufacturers Specifications must be verified first to ensure the **Coupler Brake Oil Seal Reliability.** The **Motor Shaft Runout, Mounting Face Runout and Motor Shaft to Pilot Diameter Eccentricity** need to be verified with a Dial Indicator as shown in *Figure 3.1.*

MAXIMUM ALLOWABLE T.I.R. (Inches) (As Per NEMA MG 1 Standard)

Pilot Dia. Dimension	Tolerance on Pilot Dim.		Maximum Allowable Shaft Runout	Maximum Allowable Face Runout	Maximum Allowable Eccentricity
	Plus	Minus			
Less than 12"	.000	.003	.002	.004	.004
12"& Larger	.000	.005	.003	.007	.007

CAUTION - T.I.R. in excess of this maximum will result in potential leak condition.

FORCE CONTROL INDUSTRIES, INC.

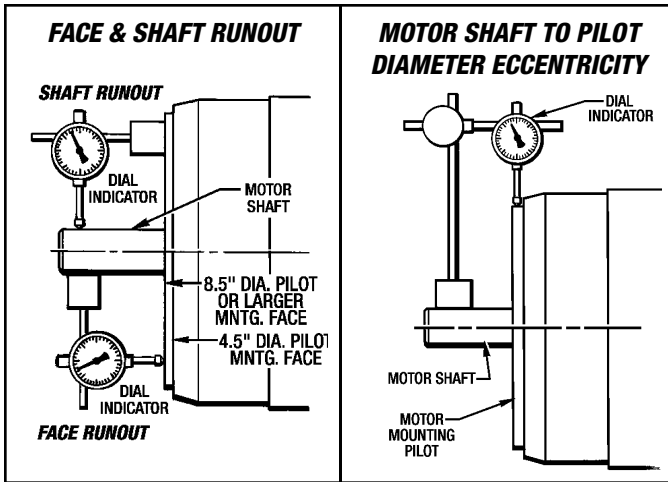

Figure 3.1 - Verifying Motor Specifications

3-3 MOUNTING THE BRAKE

(See Figure 10.2)

1. Make sure the motor shaft, pilot diameter and mating surface of the C-Face flange is clean and free of any nicks, burrs or anything that would not allow the brake to seat properly. Clean-Up and De-Burr as necessary.

IMPORTANT - Do not use any molybdenum disulfide "Molykote" or any other similar lubricant on the motor shaft. The Collet (#110) is keyless and depends on friction to transmit torque from the brake to the drive motor .

2. Install the (4) Mounting Spools (#109) and the (4) Screws (#150) to the motor face as shown in Figure 3.2. Use **Blue Loctite #271** on these screws. Only moderately tighten them up at this time. **Do not torque these (4) Screws (#150) at this time.**

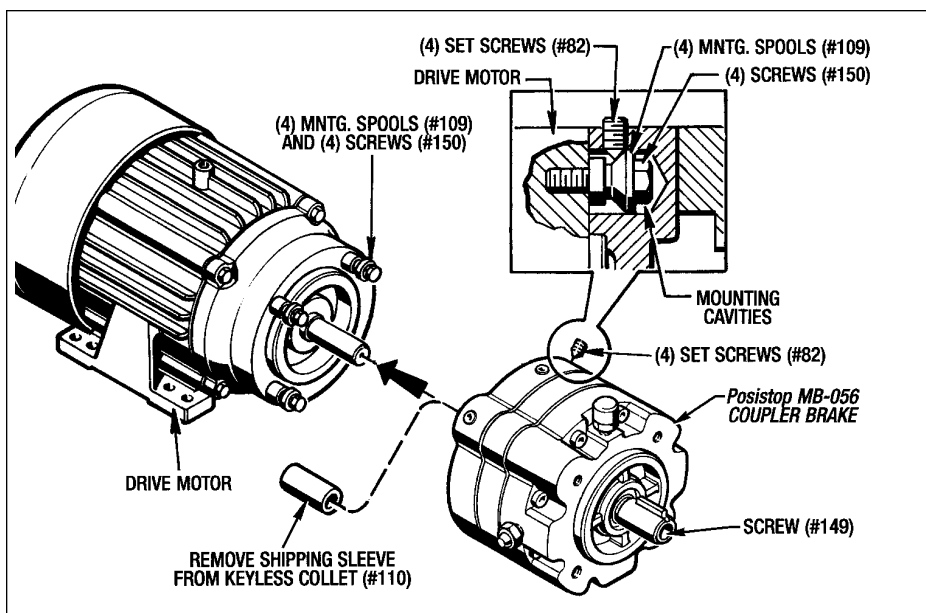

Figure 3.2- Mounting the MB-056 Coupler Brake

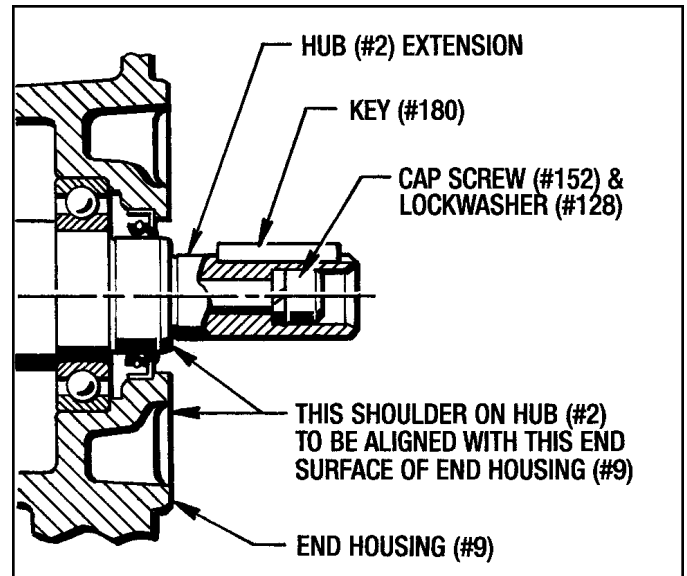

Figure 3.3 - Hub Alignment

3. Loosen the (4) Set Screws (#82) and slide the Brake on to the (4) Mounting Spools (#109). Tighten these (4) Set Screws down to correctly align the Mounting Spools.
4. Loosen the (4) Set Screws (#82) and **carefully remove** the Brake without disturbing the (4) Mounting Spools (#109).
5. Torque the (4) Mounting Screws (#150) to 25 Ft. Lbs.
6. Remove the (4) Set Screws (#82) from the Brake and apply Blue Loctite #271 to them. Re-install them back into the Brake.
7. Re-install the Brake back onto the Motor Face. **Torque the (4) Set Screws (#82) to 25 Ft. Lbs.**

8. To lock the brake to the motor shaft, tighten the Hub Locking Screw (#152). **Torque to 25 Ft. Lbs.**

NOTE - The Hub (#2) will be pulled in as the Screw (#152) is tightened. Re-align the Hub (#2) by pulling it outward while tightening the Screw (#152). The shoulder on the Hub (#2) should be in approximate alignment with the End Housing (#9) as shown in Figure 3.3.

9. Install the Key (#180) into the Hub (#2) keyway.

10. Fill with oil as specified in Section 4 - Lubrication.

3-4 MOUNTING MOTOR & BRAKE TO GEAR REDUCER

(See Figure 3.4)

It is recommended that you use a Coupling, rather than a hollow shaft to connect the Hub (#2) to the Gear Reducer.

1. Attach the Drive Motor and Brake Assembly to the Gear Box or Driven Machinery with the (4) 3/8"-16 Mounting Bolts (Customer Furnished). **Torque to 25 Ft. Lbs.** Connect the coupling as per manufacturer's specifications.
2. If the Drive Motor is to be bolted down to the base, use motor shims under the feet to properly align the drive motor with the gear reducer as shown in Figure 3.3. **This is very important so the Coupler Brake will not be pulled down or pushed up.**

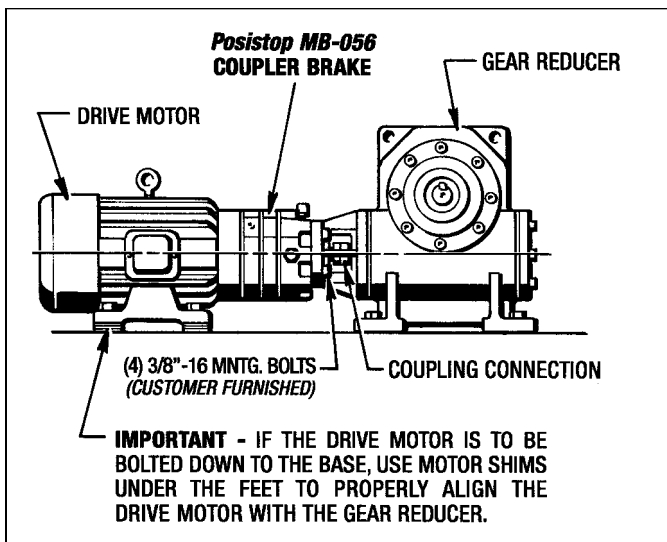

Figure 3.4 - Motor and Gear Reducer Alignment

3-5 PNEUMATIC CONTROL VALVE HOOK-UP

Figure 3.5 illustrates a typical pneumatic system for your Posistop MB-056 Coupler Brake.

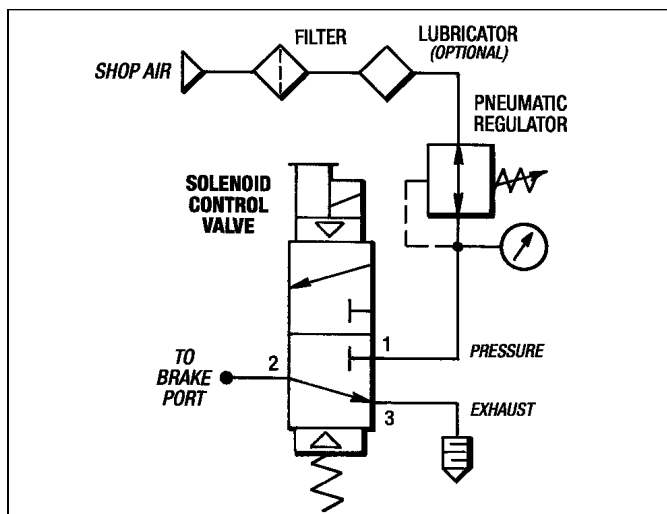

Figure 3.5 - Typical Pneumatic System

A pre-plumbed and mounted **Pneumatic Control Valve Mounting Kit** is available from **Force Control**. (See Figure 10.3.)

Note the following when planning and installing the Pneumatic System.

1. Use direct acting or pilot operated solenoid air valves to give the correct response speed required. Locate the valve as close to the brake as possible.
2. Be sure to use valves of at least .4 Cv.
3. The air pressure regulator should be sized and set to provide the required torque. (See **Section 2 - Specifications** for the required **Brake Release Pressure**.)

NOTE - The Brake Torque is directly proportional to the air pressure. Do not exceed the **Max. PSI to Release** air pressure. This will give additional life to the brake unit.

4. Hook-up appropriate electrical service to the Solenoid Control Valve as per manufacturers specifications.

3-6 VERTICAL Vs. HORIZONTAL INSTALLATION

The Installation for a Vertical Mounted Brake is the same as a Horizontal Brake described in the previous sections

The following Figure 3.6 shows the Mounting Angles that determines a Vertical Up, Horizontal or Vertical Down Installation.

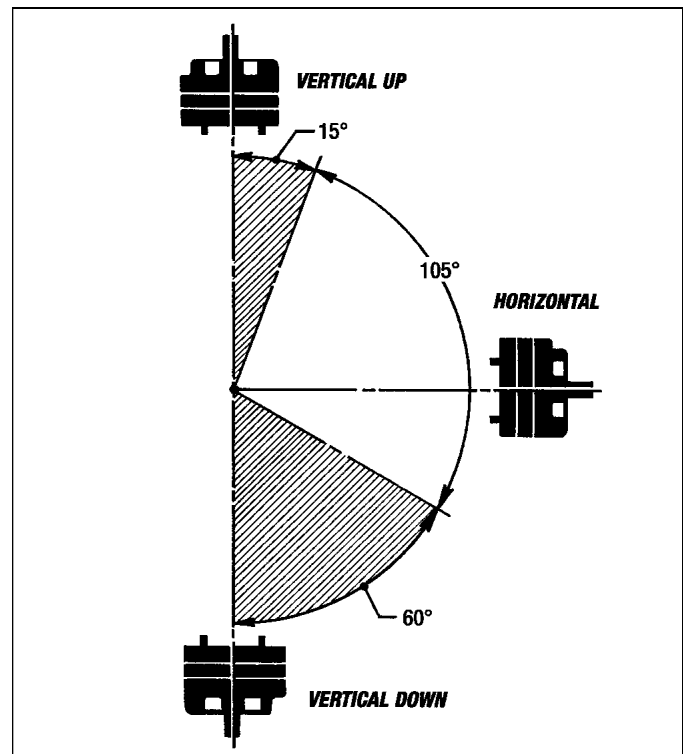

Figure 3.6 - Vertical Vs. Horizontal Installation

Section 4 LUBRICATION

4-1 CHECKING THE OIL LEVEL

Check the oil level when the brake is initially installed and weekly thereafter or until experience dictates otherwise. Always check the oil with the brake stationary. (Not Running). The oil level is as shown in the following Figures:

1. Horizontal Brake *Figure 4.1*
2. Vertical Up Brake *Figure 4.2*
3. Vertical Down Brake *Figure 4.3*

4-2 CHANGING THE OIL

IMPORTANT - Always open the disconnects to the drive motor and lock them out before changing the oil.

Change the oil in your brake every 6 months or when the color of the oil starts to darken.

CAUTION - Do not overfill the brake. Excess oil will cause the brake to overheat.

NOTE: The oil should be changed more frequently when used in harsh environments or high cyclic applications.

A. Horizontal Brake

(See Figure 4.1)

1. Remove the (2) Sq. Hd. Pipe Plugs (#50) and drain all the oil from the brake. Save or discard as condition warrants. Replace the drain plugs.
2. Remove the Air Breather (#44) from the top of the End Housing (#9) and fill the brake with fresh oil to the center of the Sight Gauge (#46) as shown in Figure 4.1. **Fluid capacity is approx. 1 Pint.**

NOTE - The Sight Gauge (#46) and Air Breather (#44) should always be removed and cleaned when the oil is changed.

B. Vertical Up Brake

(See Figure 4.2)

1. Remove the Sq. Hd. Pipe Plug (#50) from the Housing (#8) to drain the oil. Save or discard as condition warrants. Replace the drain plug.
2. Remove the Air Breather (#44) from the Elbow (#61) and fill the brake with fresh oil. Fill until the oil is at the center of the Sight Gauge (#46) as shown in Figure 4.2. **Oil capacity is approx. 1 Pint.** Replace the cleaned Air Breather (#44) after filling.

NOTE - The Air Breather (#44) and Sight Gauge (#46) should also be removed and cleaned when the oil is changed.

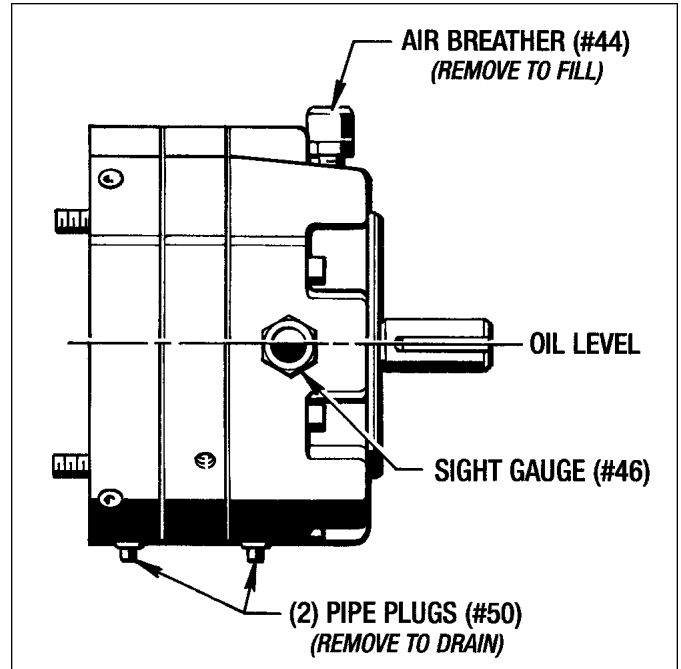

Figure 4.1 - Horizontal Brake Lubrication

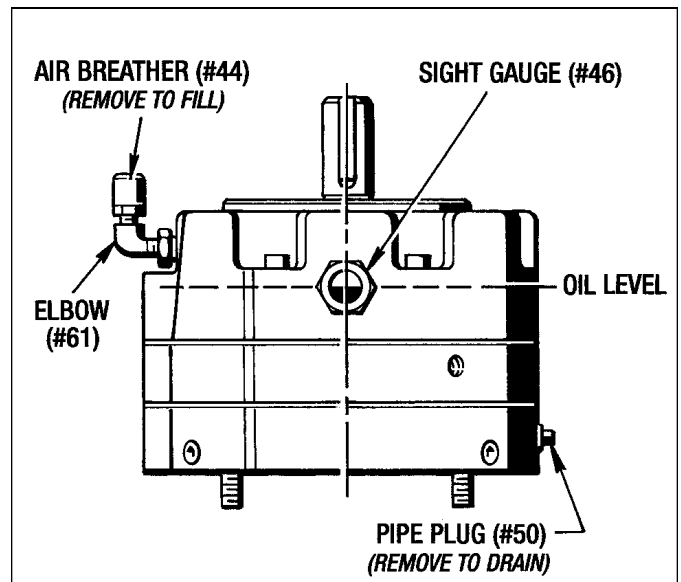

Figure 4.2 - Vertical Up Brake Lubrication

C. Vertical Down Brake

(See Figure 4.3 on next page.)

1. Remove the Sq. Hd. Pipe Plug (#50) from the End Housing (#9) to drain the oil. Save or discard as condition warrants. Replace the plug after draining the oil.
2. Remove the Sq. Hd. Pipe Plug (#74) from the Elbow (#66) to fill the brake with fresh oil to the top of the Elbow (#66) as shown in Figure 4.3. **Oil capacity is approx. 1 Pint.** Replace the Plug (#74).

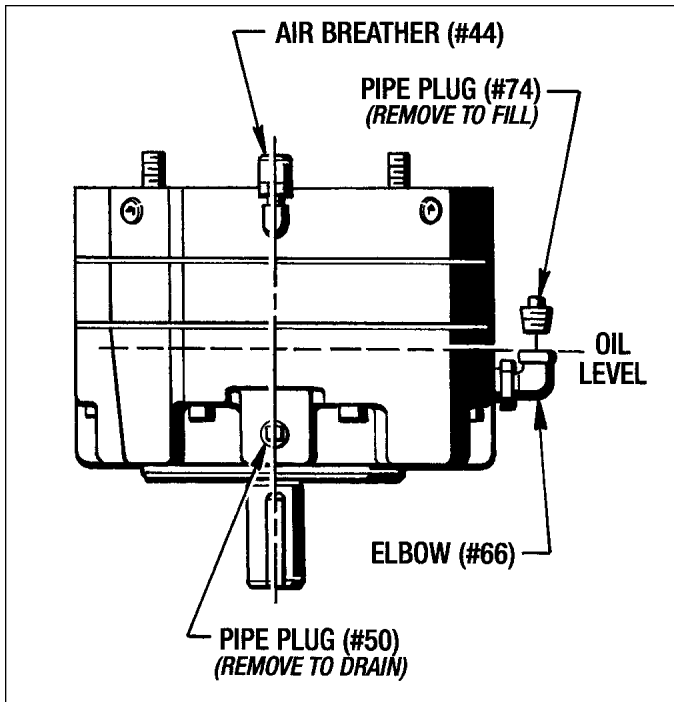

Figure 4.3 - Vertical Down Brake Lubrication

4-3 TYPE OF OIL

Use only Mobil Automatic Transmission Fluid ATF-210 Type "F" or Mobil Multi-purpose Automatic Transmission Fluid.

Other fluids may be used for special applications.

Always use the type of fluid specified on the name plate. If the name plate is missing or if there is any doubt about the correct fluid to use contact Force Control Industries, Inc.

Section 5 OPERATIONAL CHECKS

WARNING

Make these Operational Checks only when the brake unit is not in operation. Open the motor disconnect and lock it out to avoid any personal injury.

5-1 OPERATIONAL CHECKS

Provisions for manual operation is to be made if the brake has been removed for service and repair. Set up a temporary manually controlled air supply with a quick acting shut-off valve and a pressure gauge. (See Figure 5.1)

1. Apply air pressure to the brake and quickly shut the air off. Observe the pressure gauge to see if there is a significant pressure drop.

If there is a pressure drop of 5 PSI or more within 30 seconds, then the brake is not operating properly.

This would indicate that the piston seals or gaskets are worn or damaged and would need replaced.

2. Exhaust the air pressure and attempt to manually turn the Hub (#2) extension. The hub should be locked in position. If the hub can be turned then the piston did not return to the normal braked position.

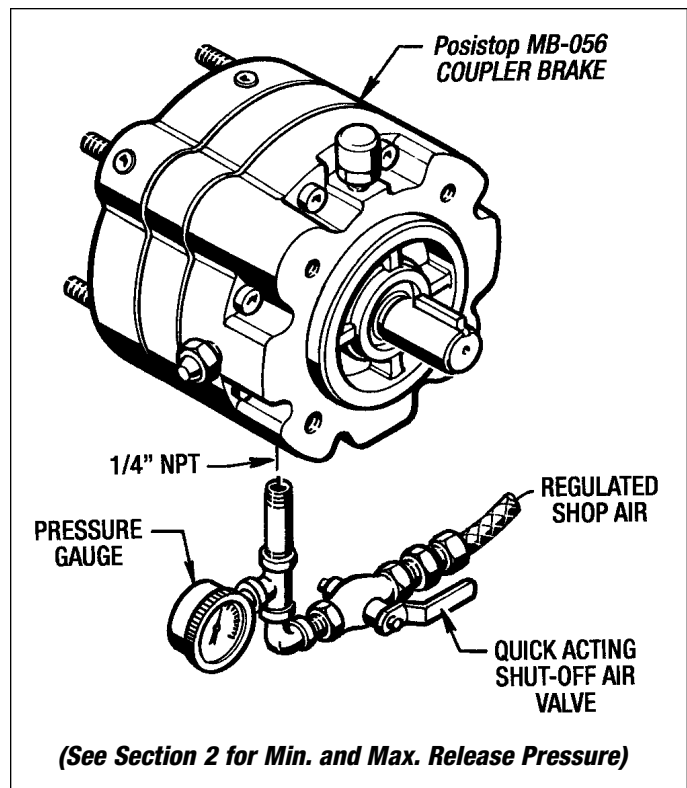

Figure 5.1 - Set-Up for Operational Checks

Section 6 TROUBLESHOOTING

6-1 TROUBLESHOOTING CHART

TROUBLE	POSSIBLE CAUSE	REMEDY
A. Brake fails to engage properly.	Pistons sticking or binding. Worn Friction Discs. Weak or broken springs. Air pressure not exhausting or slow in exhausting.	Disassemble to the extent necessary and inspect for damaged parts. Replace brake stack. Replace as needed. Check control valve or muffler and clean or replace as necessary.
B. Brake engages too quickly.	Low oil level.	Check oil level and correct.
C. Noise and vibration.	Improper or loose mounting on motor and/or gear reducer.	Check mounting bolts and alignment. If partial disassembly is required refer to Section 3 - Installation.
D. Brake fails to disengage properly.	Low air pressure. Piston sticking or binding Control valve not functioning properly.	Increase air pressure. (See Section 2) Disassemble to the extent necessary and inspect for damaged parts. Check valve operation and replace if necessary.
E. Brake overheats (Over 225° F.)	Brake not engaging or disengaging properly causing excessive slippage. Improper oil level.	Refer to troubles A and D. Check oil level and correct.
F. Oil leakage.	Oil seal lip or wear sleeve damaged. Bad alignment. External bolts not tight. Gaskets damaged.	Check for oil leaking around shaft. Replace if necessary. Check and correct alignment. Tighten all external bolts. Check and replace if necessary.
G. Oil leakage at breather.	Oil level too high.	Drain excess oil.
H. Brake does not repeat.	Air pressure changed. *Oil temperature changed. Inconsistent stopping signal.	Check and adjust air pressure. Check temperature. Check control circuit.

* - **NOTE:** For installations requiring precise starting and stopping, operating temperatures are very important. Operating temperatures between 116° F. and 165° F. are recommended.

6-2 MEASURING BRAKE STACK HEIGHT

To determine whether or not the Brake Stack is worn enough to replace, the Stack has to be measured as shown in *Figure 6.1*.

Clamp the Brake Stack in an arbor press and measure the height.

NOTE - Do not include the Separator Springs (#17) when measuring the **Stack Height**.

The Minimum Stack Height is as follows:

Short Brake Stack(.382")

Full Brake Stack(.384")

If the **Brake Stack Height** measures the **Minimum Brake Stack Height** or under, replace the Brake Stack.

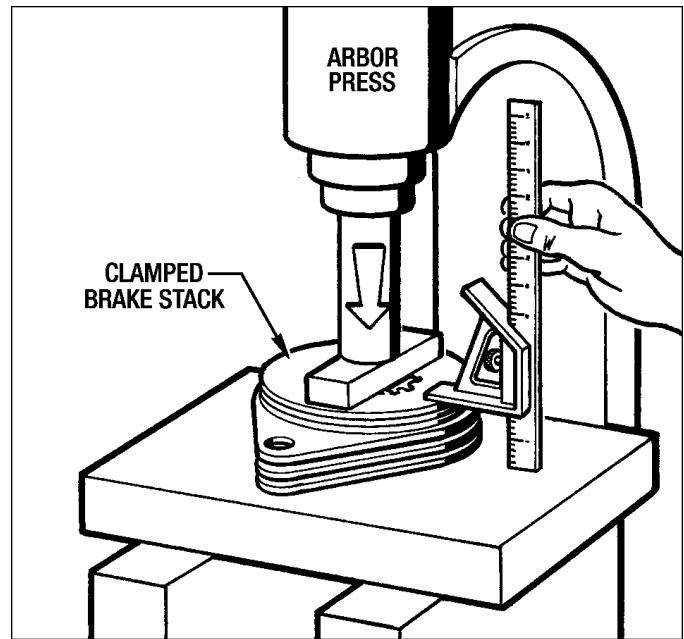

Figure 6.1 - Measuring Brake Stack Height

Section 7 DISASSEMBLY

WARNING

Before attempting to disassemble or remove the *Posistop MB-056 Coupler Brake*, open the motor disconnect, shut-off the control electrical supply and the air supply. Lock them all out to avoid any personal injury.

Support and block all loads on vertical units before removing or disassembly of the brake.

Unless the Brake is to be completely overhauled, it should only be disassembled to the extent necessary to gain access to the worn or damaged parts.

See the following Figures in **Section 10** for a visual reference to all parts.

Figure 10.1 - Short Brake Stack.

Figure 10.2 - Main Assembly - Posistop MB-056 Coupler Brake.

Figure 10.3 - Vertical Installation.

Figure 10.3 - Pneumatic Control Valve Mounting Kit.

It is recommended that all disassembly and repairs be done on a work bench. Also remove the Drive Motor and Coupler Brake together as an assembly from the Gear Reducer.

7-1 REMOVING COUPLER BRAKE AND DRIVE MOTOR FROM GEAR REDUCER

(See *Figure 7.1*)

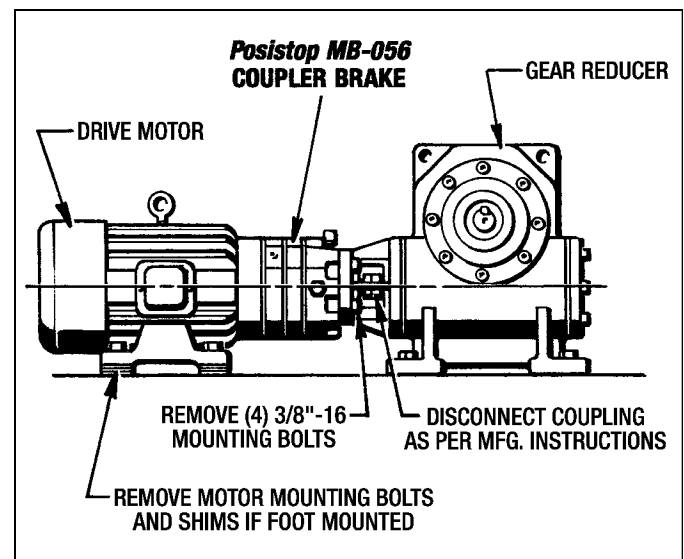

Figure 7.1 - Removing Brake and Motor From Gear Reducer

1. Disconnect any pneumatic lines and electrical connections from the Pneumatic Control Valve.
2. Loosen Coupling Connection as per Manufacturer's Specifications.
3. Remove the (4) 3/8"-16 mounting bolts from the Gear Reducer C-Face Flange.

4. If the Drive Motor is foot mounted, then remove the (4) motor mounting bolts, lockwashers and any shims that might be under the motor feet.
5. With an appropriate sling and overhead hoist pull the Drive Motor and Coupler Brake away from the gear reducer and take it to a work bench for further disassembly.
6. Take the Key (#180) out of the Hub (#2) keyway.
7. Drain all the oil out of the brake as described in **Section 4 - Lubrication**.

7-2 REMOVING END HOUSING (#9) FOR ACCESS TO THE BRAKE STACK

If replacement of the Brake Stack is the only repair to be made, the End Housing (#9) just has to be removed to gain access to the Brake Stack. The remaining brake assembly does not have to be taken off the drive motor.

1. Remove the (4) Screws (#72), (4) Screws (#149) and (8) Lockwashers (#127) from the End Housing (#9).

NOTE - If you have a brake mounted control valve, there will also be (2) Screws (#273) and (2) Lockwashers (#275). Remove them and disconnect the air hose under the brake. Take the Control Valve (#270) and Mounting Bracket (#271) off the End Housing (#9). (See Figure 10.3)

2. Pry the End Housing (#9) loose and pull it straight back off the remaining brake assembly. **Be very careful not to damage the lip of Oil Seal (#35) located in the End Housing (#9).**
3. Remove and discard the Gasket (#122).
4. Remove the **Brake Stack** from the Hub (#2) spline and the (2) Dowel Pins (#176).

5. Measure the **Brake Stack Height** as described in **Section 6 - Trouble Shooting** on the previous page 10 to see if the Stack is worn enough to replace.

7-3 REMOVING HUB (#2)

1. Remove the Screw (#152) and Lockwasher (#128) from the end of the Hub (#2).

A special **Threaded Rod** and **Jack Bolt** has to be used to loosen the Collet (#110) from the Hub (#2) bore. Dimensions and specifications are given in Figure 7.3.

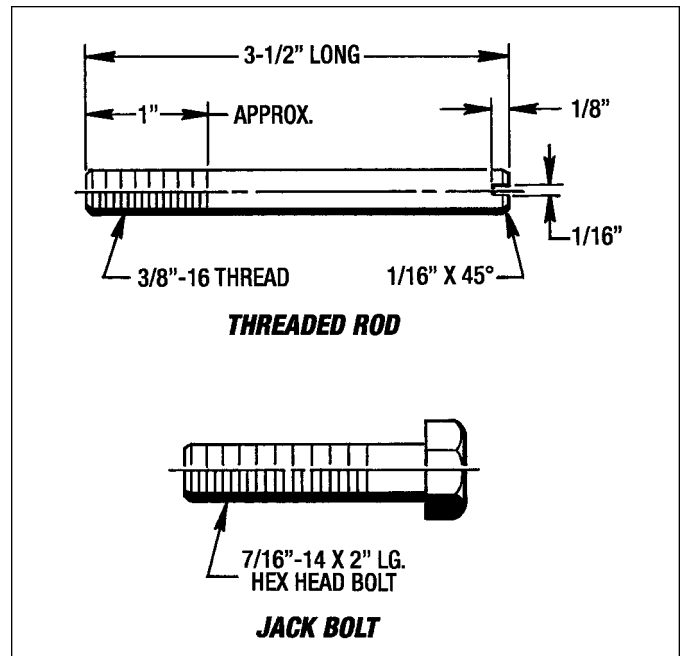

Figure 7.3 - Disassembly Tools

NOTE - The **Threaded Rod** can just be a 3-1/2" to 4" long cap screw with the head cut off.

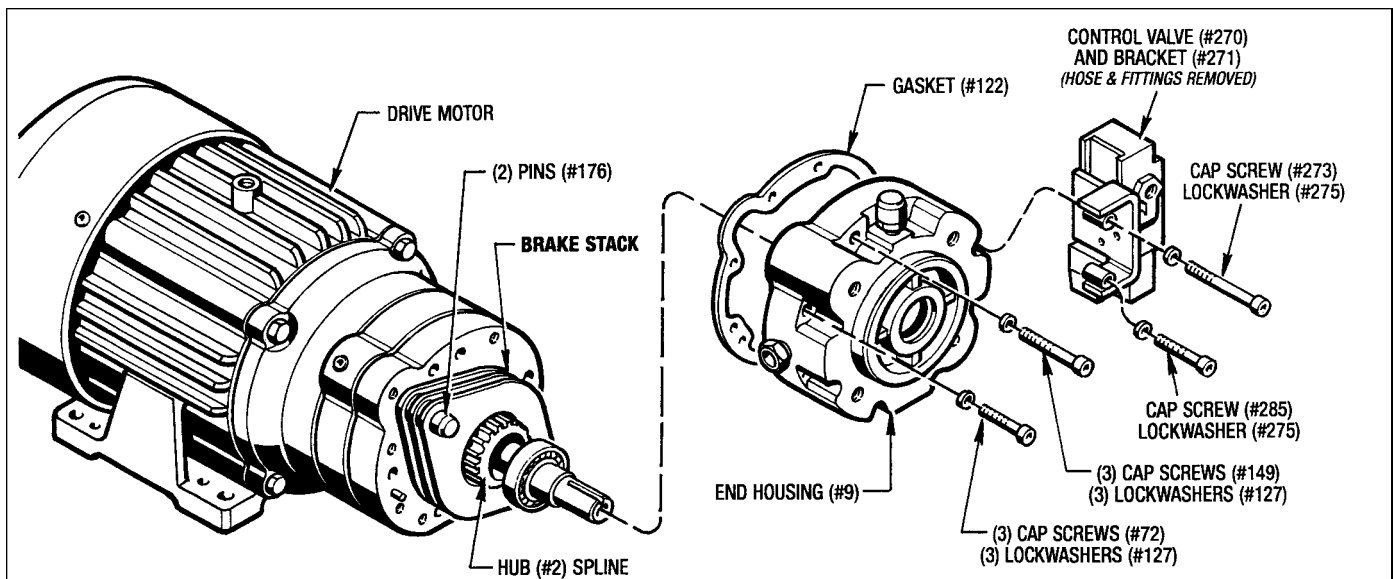

Figure 7.2 - Access to Brake Stack

2. Insert the **Threaded Rod** into the end of the Hub (#2) and thread it into the Collet (#110) with a flat head screw driver. Leave about 1-1/4" from the end of the Hub (#2) as shown in *Figure 7.4*.
3. Screw the **Jack Bolt** into the Hub (#2) and tighten to release the Collet (#110). Remove the **Jack Bolt** and **Threaded Rod**.

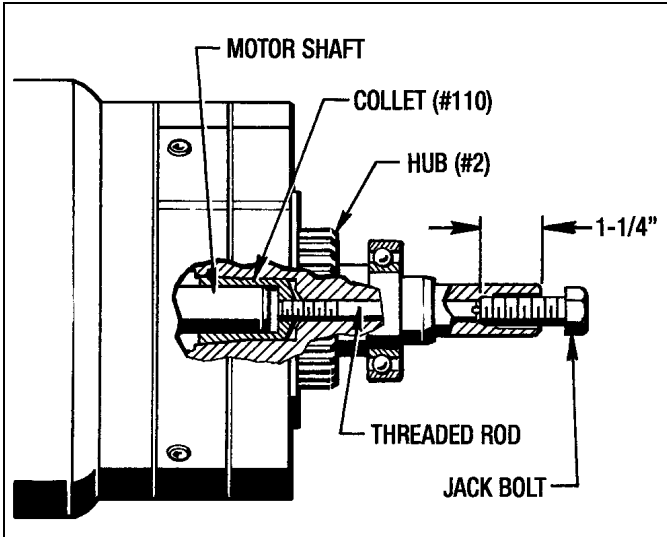

Figure 7.4 - Loosening Collet (#110) from Hub (#2)

4. Grasp the Hub (#2) and carefully pull it straight out of the brake and off the motor shaft. **Be very careful not to damage the lip of the Oil Seal (#31) when removing the Hub (#2).**
5. Take the Collet (#110) out of the Hub (#2) bore or off the motor shaft.

7-4 HUB (#2) DISASSEMBLY

A. Removing Wear Sleeve (#32)

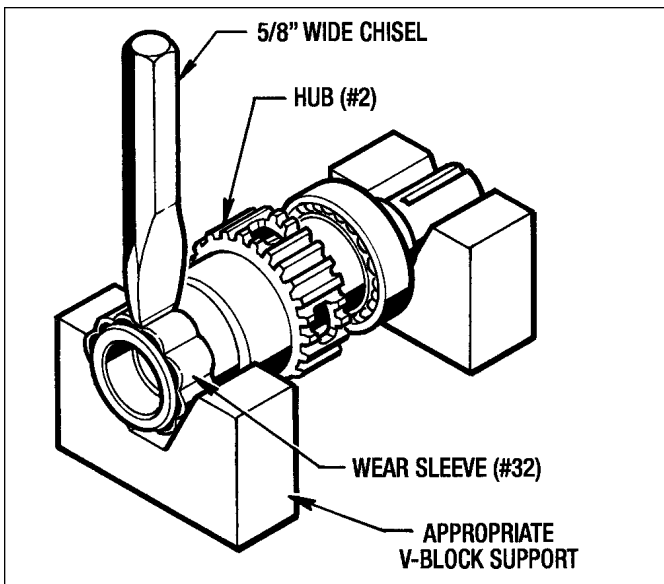

Figure 7.5 - Removing Wear Sleeve (#32)

1. Set the Hub (#2) into appropriate V-Block Supports as shown in *Figure 7.5*. With a 5/8" wide chisel and a mallet, make 6 or 8 notches in the Wear Sleeve (#32). Pry the Wear Sleeve (#32) off the Hub (#2).

B. Removing Bearing (#20)

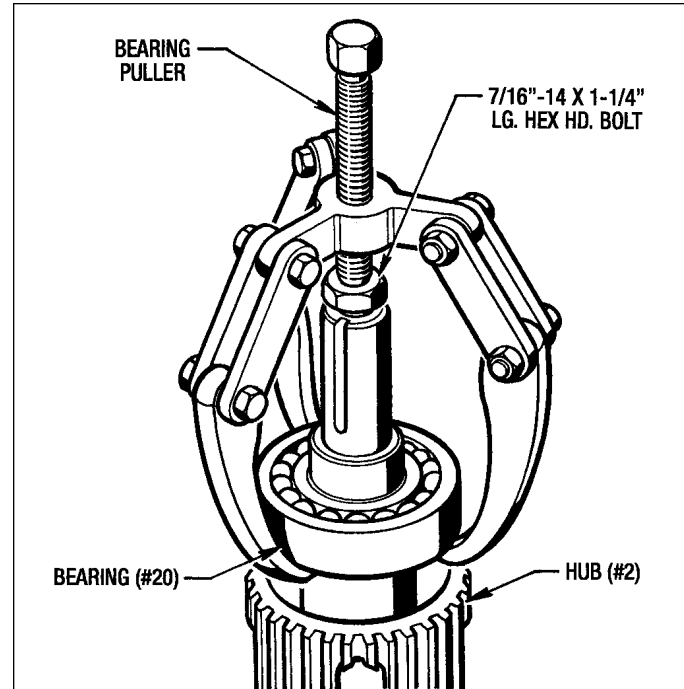

Figure 7.6 - Removing Bearing (#20)

1. Use a standard Bearing Puller to remove the Bearing (#20) off the Hub (#2) as shown in *Figure 7.6*.

7-5 REMOVING PISTON HOUSING (#10) AND PISTON (#3) TO REPLACE PISTON SEALS

(See *Figure 10.2*)

1. Carefully remove the (4) Screws (#153) and (4) Lockwashers (#167).

CAUTION - This Piston Housing (#10) is under spring pressure so evenly back out these (4) screws to avoid any personal injury.

2. Take the Piston Housing and Piston Sub-Assembly off the Housing (#8).
3. Take the Springs (#36) out of the spring pockets. Make a free-hand sketch of the spring locations. *This will help at Re-assembly.*
4. Remove the Gasket (#121) and discard it.
5. Pull the Piston (#3) out of the Piston Housing (#10).
6. Remove the Liner (#43) and (2) O-Rings (#40) from the Piston (#3). Also take the Liner (#42) and both O-Rings (#39) out of the Piston Housing (#10) as shown in *Figure 7.7*.

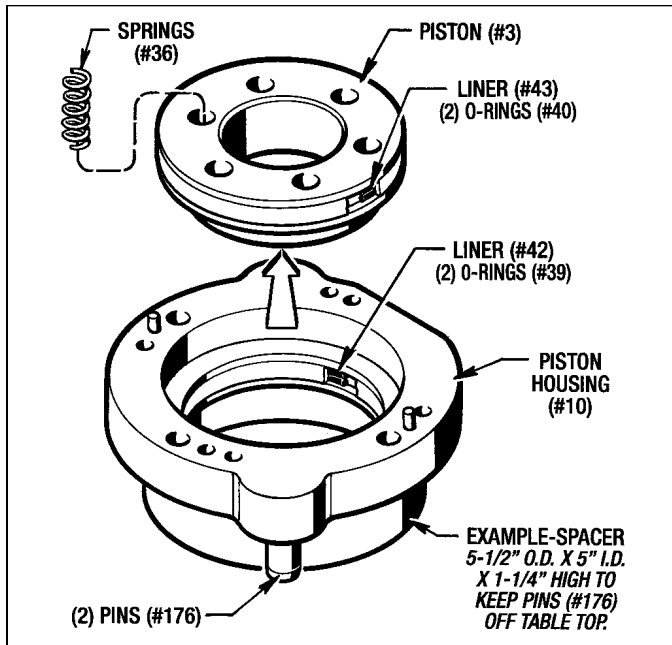

Figure 7.7 - Removing Piston Seals

7-6 REMOVING OIL SEALS

A. Oil Seal (#31)

This oil seal is located in Housing (#8).

1. Loosen the (4) Set Screws (#82) and pull the Housing (#8) off the motor face.
2. Using a suitable punch, knock the Oil Seal (#31) out of the Housing (#8) bore.

B. Oil Seal (#35)

This oil seal is located in the End Housing (#9).

1. Use an arbor press to remove this Oil Seal (#35) from the End Housing (#9).

This completes the Disassembly Procedure for your MB-056 Coupler Brake.

Section 8 CLEANING AND INSPECTION

8-1 CLEANING AND INSPECTION

Clean metal parts in a suitable solvent and dry in a stream of low pressure compressed air. The Brake Drive Discs (#13), Filler Plates (#57) and Shims (#184) can be cleaned in a solvent, but **DO NOT clean the Brake Friction Plates (#12) and/or (#38) in solvent.** Use only a clean, dry and lint-free rag to clean these Friction Plates. (Solvent will damage the resilient paper-based friction material used on the Friction Plates. Keep the Friction Plates and Drive Discs in the same order as they were removed. After cleaning, inspect parts for cracks, distortion, scoring, nicks, burrs or other damage would affect serviceability. Pay particular attention to the following:

1. Check the friction plates wear surfaces for scoring, galling or evidence of uneven wear.
2. Check the brake drive discs for scoring or galling. Make sure they are flat. If a perceptible ridge is worn in any of the drive discs, replace all of the drive discs and friction plates as a complete set.
3. Carefully check the piston and bore surfaces for nicks, scratches, scoring or other damage which would affect operation or cause leakage.
4. Carefully check the Piston Liners (#42) and (#43) and the O-Rings (#39) and (#40) for wear or any condition that would cause leakage.

5. Pay particular attention to the Wear Sleeve (#32) located on the Hub (#2) and the (2) Oil Seals (#31) and (#35). Check for nicks or scratches which would cause leakage. Replace any damaged parts.
6. It is not necessary to remove the Ball Bearing (#20) to check the operation. Slowly rotate the free race of the bearing by hand checking to see if it turns freely without any rough or flat spots.
7. Periodically remove the Muffler (#282) located in the exhaust port of the Pneumatic Control Valve (#270) and clean it with a suitable solvent.

8-2 REPAIR AND REPLACEMENT

A fine stone or crocus cloth may be used to remove minor surface defects from parts so long as the operating or sealing action of the part is not affected. The use of coarser abrasives or other machining methods should not be attempted. Otherwise, damaged parts should be replaced.

Replacement is recommended also for the following, as applicable:

1. Replace all O-Rings, Liners, Gaskets and Oil Seals removed during the course of disassembly.
2. Replace all Brake Stack Components - Friction Plates, Drive Discs, Filler Plates and Shims in complete sets only.

Section 9 REASSEMBLY

9-1 GENERAL REASSEMBLY INSTRUCTIONS

See the following Figures in **Section 10** for a visual reference to all parts.

Figure 10.1 - Short Brake Stack.

Figure 10.2 - Main Assembly - Posistop MB-056 Coupler Brake.

Figure 10.3 - Vertical Installation.

Figure 10.3 - Pneumatic Control Valve Mounting Kit.

Note the following general reassembly instructions as applicable:

1. Lubricate O-Rings, Liners and Oil Seal lips with "**Mobilith**" **SHC-PM Synthetic Grease**, or equivalent, immediately before reassembly or the installation of mating parts. This will be referred to as **White Grease** hereafter in the Reassembly Instructions.
2. The Ball Bearing (#20) can be installed on the Hub (#2) either of two ways. It can be heated up to 200° F. and just dropped on the shaft or it can be pressed on with an arbor press.
3. Use **Red Loctite #271** when installing the Wear Sleeve (#32) on the Hub (#2).
4. Use Removable **Blue Loctite #272** on the (4) Set Screws (#82) that locks the brake to the (4) Mounting Spools attached to the motor face.
5. Use **Permatex #30 Sealant** on the O.D. of both Oil Seals (#31) and (#35) when installing them.
6. Do not use any Gasket Sealant when installing the (2) Gaskets (#121) and (#122).
7. Any Cap Screws that have Lockwashers do not require any thread adhesive to be applied to the threads.

9-2 INSTALLING OIL SEALS

1. First thoroughly clean the bores in both Housings (#8) and (#9) with a suitable solvent. Make sure they are clean and free of any foreign material.
2. Coat the oil seal bores with a thin coat of **Permatex #30 Sealant**.
3. Press the Oil Seal (#31) into the Housing (#8) with an arbor press until it bottoms out on the retaining shoulder. as shown in *Figure 9.1*.
4. Press the Oil Seal (#35) into the Housing (#9) with an arbor press until it bottoms out on the retaining shoulder. as shown in *Figure 9.1*.
5. Clean off any excess sealant.

A. Installing Oil Seal (#31)

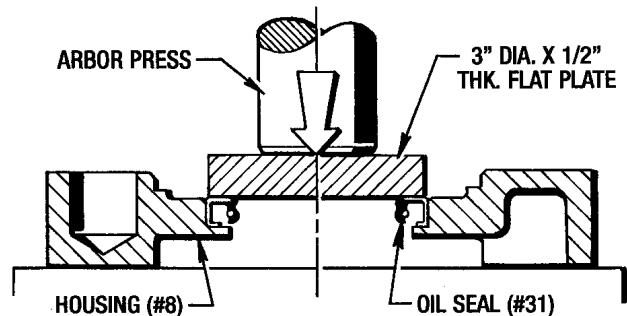

B. Installing Oil Seal (#35)

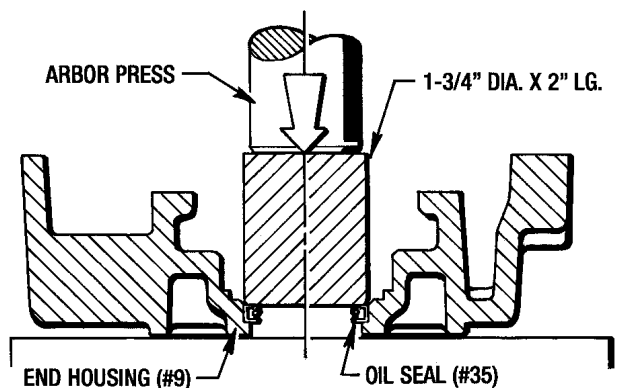

Figure 9.1 - Installing Oil Seals

9-3 INSTALLING HOUSING (#8) TO DRIVE MOTOR

(See *Figure 10.2*)

1. Make sure that the motor shaft, pilot diameter and mating surfaces of the C-Face Flange is clean and free of any nicks, burrs or anything that would not allow the Housing (#8) to seat properly.
2. Remove the (4) Set Screws (#82) from the Housing (#8) and clean them with solvent. Apply **Blue Loctite #272** to the screws and re-install them.
3. Place the Housing (#8) on to the motor face. The (4) Mounting Spools (#109), which are attached to the motor, go into the (4) mounting cavities. Tighten the (4) Set Screws (#82) in an even manner to lock the Housing (#8) to the drive motor. **Torque to 25 Ft. Lbs.**

9-4 PISTON (#3) AND PISTON HOUSING (#10) REASSEMBLY

(See Figures 9.2 and 9.3)

1. Lubricate the (2) O-Rings (#40) and the Teflon Liner (#43) with **White Grease** and install them onto the Piston (#3).
2. Lubricate the (2) O-Rings (#39) and the Teflon Liner (#42) with **White Grease** and install them into the Piston Housing (#10).
3. Insert the Piston (#3) into the Piston Housing (#10).

Coat all mating surfaces and liners with a thin coat of **White Grease** before installing the Piston (#3). **Also be very careful not to damage the Liners when installing this Piston (#3) into the Piston Housing (#10).**

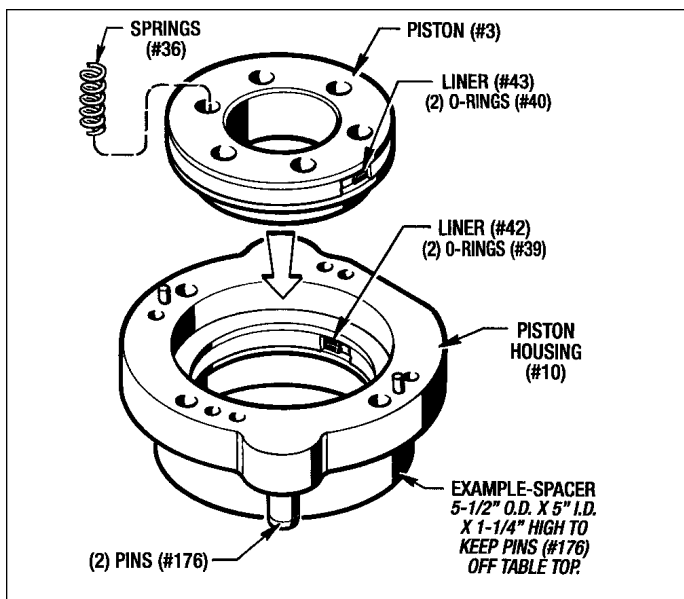

Figure 9.2 - Installing Piston (#3) and Piston Housing (#10)

4. Place the correct number of Springs into the Piston (#3). See Figure 9.3 for Correct Spring Placement.

White Grease can be used to hold them in place.

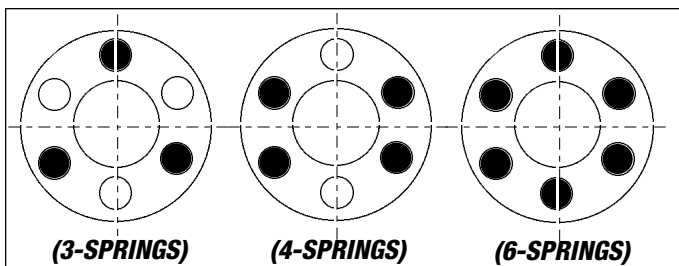

Figure 9.3 - Correct Spring Placement

5. Place the Gasket (#121) on the Piston Housing (#10). Use the (2) Pins (#158) for correct placement.
6. Attach the Piston Housing (#10) to the Housing (#8) with (4) Screws (#153) and (4) Lockwashers (#167).

FORCE CONTROL INDUSTRIES, INC.

Tighten these screws down in an even manner to correctly compress the Springs (#36). **Torque to 7 Ft. Lbs.**

Also make sure that the (2) Dowel Pins (#176) are in place in the Piston Housing (#10).

9-5 HUB (#2) REASSEMBLY

(See Figure 9.4)

A. Installing Wear Sleeve (#32)

1. First make sure the Hub (#2) diameter is thoroughly cleaned. Apply **Red Loctite #272** to the Hub (#2) and as shown in Figure 9.4 install the Wear Sleeve (#32) on the Hub (#2) with an arbor press until it bottoms out on the hub shoulder. Clean off any excess adhesive.

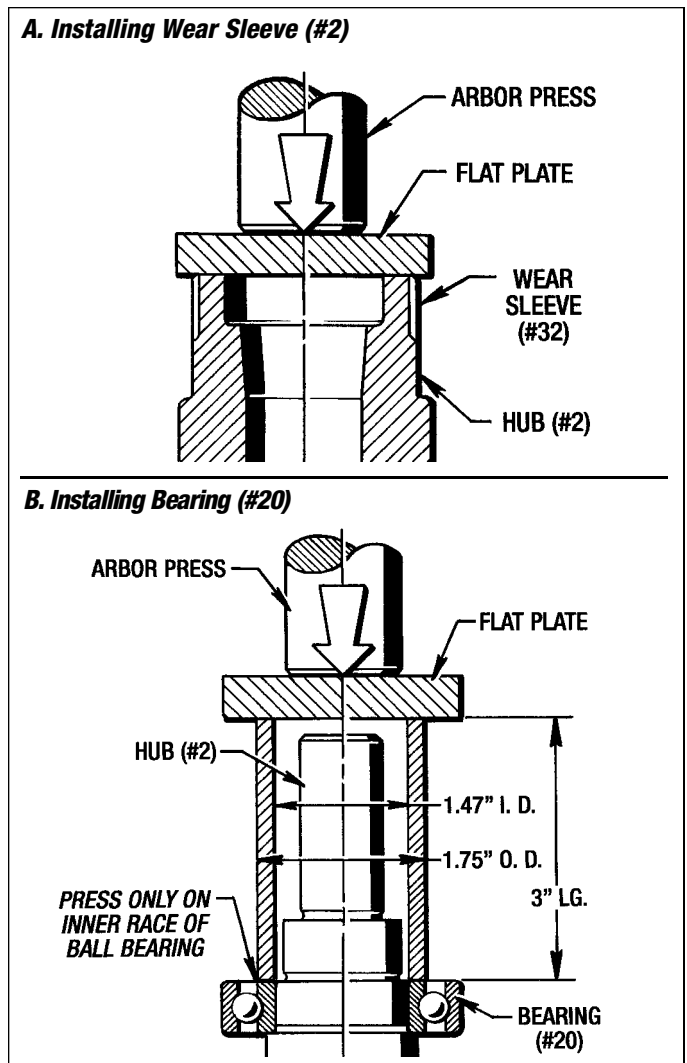

Figure 9.4 - Hub Reassembly

B. Installing Bearing (#20)

1. Heat up the Bearing (#20) to 200° F. and drop it on to the Hub (#2) or press it on with an arbor press as shown in Figure 9.4.

CAUTION - Be sure to wear suitable gloves when handling heated parts.

9-6 INSTALLING HUB (#2) INTO BRAKE

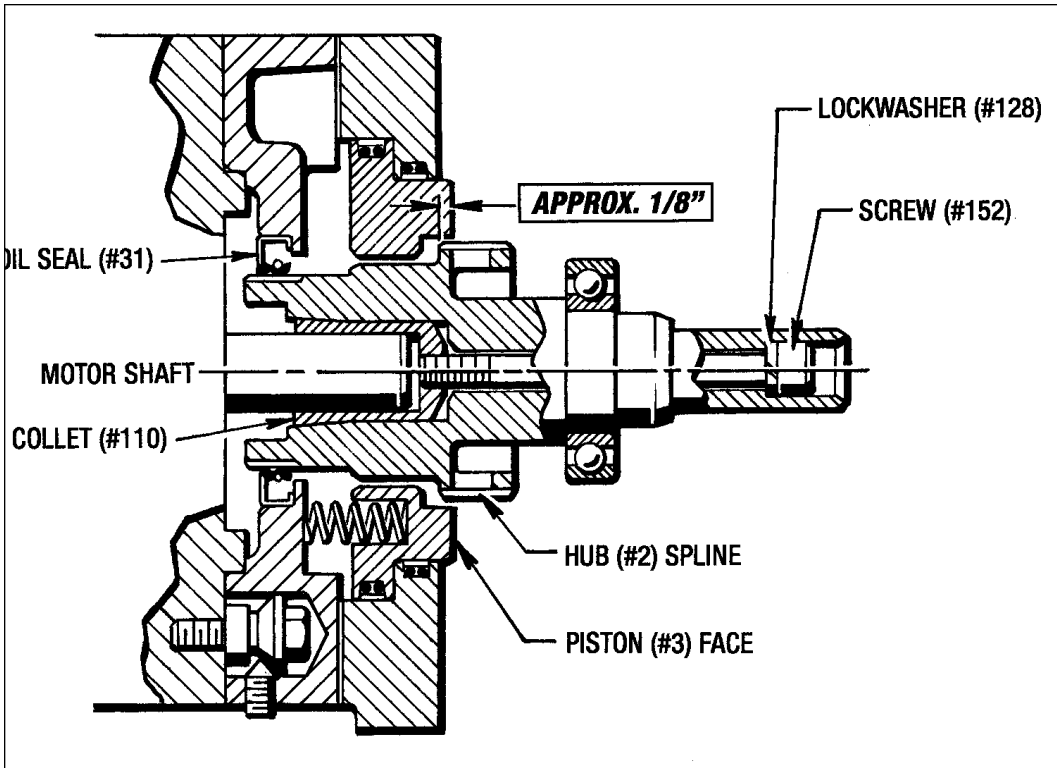

Figure 9.5 - Installing Hub (#2)

1. Place the Collet (#110) into the Hub (#2) bore. Insert the Screw (#152) and Lockwasher (#128) into the other end of the Hub (#2). Thread the Screw (#152) into the Collet (#110). **Do not tighten this screw yet.**
2. Apply a thin coat of **White Grease** to the Wear Sleeve (#32) on the Hub (#2) and the lip of Oil Seal (#31) located in the Housing (#8).

IMPORTANT - Do not use any lubricant on the motor shaft or on the Collet (#110).

3. Carefully insert the Hub (#2) on to the motor shaft and into the Oil Seal (#31) until the back edge of the Hub (#2) spline is approx. 1/8" past the Piston (#3) face as shown in *Figure 9.5*.

NOTE - If the Collet (#110) does not slip on the motor shaft easily, then loosen the Screw (#152) a little and tap it so the Collet (#110) will loosen up in the Hub (#2) bore

4. Re-tighten the Screw (#152) just to hold the Hub (#2) in place. **Do not torque this screw yet.**

9-7 REPLACING THE BRAKE STACK

A. Full Brake Stack

(See Figure 9.6)

1. First, place a one sided Friction Plate (#38) over the Hub (#2) and on the (2) Pins (#176). *The friction material goes on the outside.*

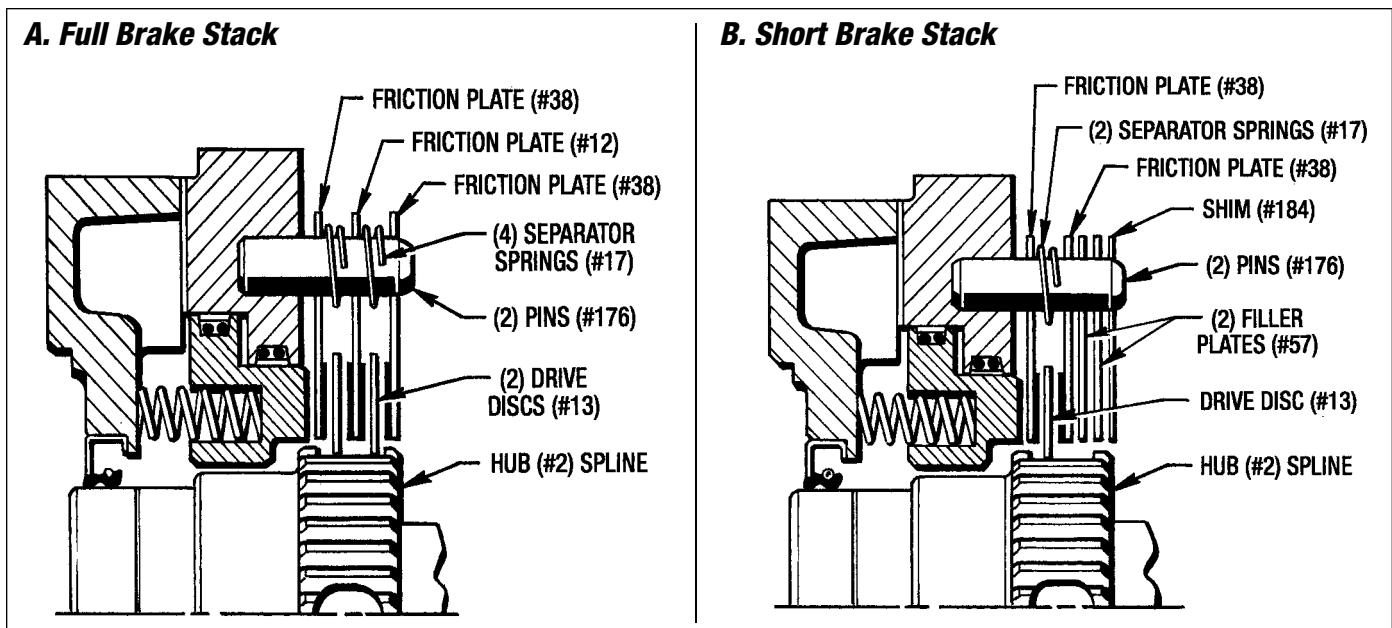

Figure 9.6 - Installing Brake Stacks

2. Place a Separator Spring (#17) over each Pin (#176).
3. Place a Drive Disc (#13) on to the Hub (#2) spline.
4. Place a double sided Friction Plate (#12) on the (2) Pins (#176).
5. Now place (2) more Separator Springs (#17) on the (2) Pins (#176).
6. Place another Drive Disc (#13) on the Hub (#2) spline.
7. Last, place a one sided Friction Plate (#38) on the (2) Pins (#176). *The friction material goes on the inside this time.*

B. Short Brake Stack

(See Figure 9.6)

1. First, place a one sided Friction Plate (#38) over the Hub (#2) and on the (2) Pins (#176) . *The friction material goes on the outside.*
2. Place a Separator Spring (#17) over each Pin (#176).
3. Place a Drive Disc (#13) on to the Hub (#2) spline.
4. Place a one sided Friction Plate (#38) on the (2) Pins (#176). *The friction material goes on the inside.*
5. Place (2) Filler Plates (#57) over the (2) Pins (#176).
6. Last, place (1) shim (#184) over the (2) Pins (#176).

9-8 INSTALLING END HOUSING (#9)

1. Put the Gasket (#122) on the Piston Housing (#10) mounting face. Use the (2) Pins (#158) for locating the gasket. **Do not use any Gasket Sealant on this gasket.**
2. Lightly coat the lip of the Oil Seal (#35) located in the End Housing (#9) with **White Grease**.

3. Very carefully slide the End Housing (#9) over the Hub (#2) and attach it to the Piston Housing (#10) with the appropriate mounting screws and lock-washers. (See Figure 9.7) Use the (2) Pins (#158) for positioning.

CAUTION - Be very careful not to damage the lip of the Oil Seal (#35) when installing this End Housing (#9).

4. Lock the Brake to the Motor Shaft and align the Hub (#2) with the same procedure as described in **Section 3-3 Mounting the Brake (Step #8)** and as shown in Figure 3.3.
5. Install the Key (#180) into the keyway if necessary.

9-9 FINAL REASSEMBLY

1. Install the Air Breather (#44), Sight Gauge (#46) and any other Pipe Plugs and Fittings removed for Disassembly.
2. Check the Operation of the Brake as described in **Section 5 - Operational Checks**.
3. Fill the brake with fresh oil as described in **Section 4 - Lubrication**.
4. Return the brake to the service location.
5. Mount the Brake and Motor to the Gear Reducer as described **Section 3-4** on page 6.
6. Connect shop air and electrical service to the Control Valve.

Your Posistop MB-056 Coupler Brake is now ready for service.

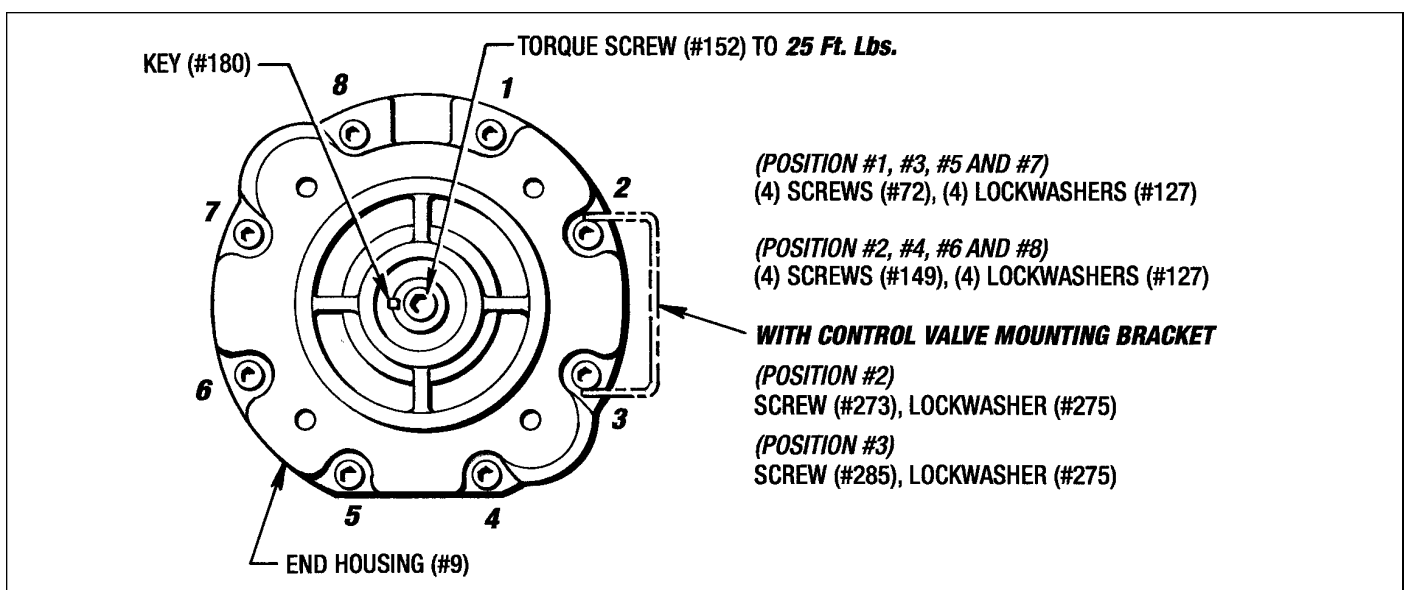

Figure 9.7 - Installing End Housing (#9)

Section 10

ORDERING REPLACEMENT PARTS

10-1 GENERAL INFORMATION

This section illustrates, lists and describes all parts for the **Posistop MB-056 Coupler Brake**.

Parts are identified on the exploded views with Part Reference Numbers. These Numbers correspond to the Part Reference Number given in the Parts Lists. The Part Name and Quantity Used is also given in the Parts List. This Part Reference Number, Part Name and Quantity should be used when ordering Replacement Parts.

10-2 FACTORY REBUILD SERVICE

Reconditioning Service is offered by Force Control Industries, Inc. at the factory. A complete factory rebuild will be 50% the cost of a new unit if the housings are reusable. If Housings need to be replaced, there will be an additional cost.

Contact **Force Control Industries, Inc.** for authorization and shipping instruction before returning a drive unit for this service. **Force Control** cannot be responsible for units returned to the factory without prior notice and authorization.

Care must be given to the packing of returned brakes. Always protect mounting surfaces by attaching to a skid. Shipment-damaged brakes always delays repairs. It is usually impossible to recover damage costs from the carrier. When possible, describe the problem experienced on your shipping papers.

Return to: **Force Control Industries, Inc.**
3660 Dixie Highway
Fairfield, Ohio 45014
Phone: (513) 868-0900
Fax: (513) 868-2105
E-Mail: info@forcecontrol.com

10-3 ORDERING REPLACEMENT PARTS

When ordering replacement parts, please specify all of the following information:

1. **Brake Model Number.** (On the Name Plate.)
(See below.)
2. **Brake Serial Number.** (On the Name Plate.)
3. **Part Reference Number.** (From the parts list or exploded view drawing.)
4. **Part Name.** (From the parts list.)
5. **Quantity.** (From the parts list.)
6. **Complete Shipping Information.**

Failure to include information for items 1 through 6 will only delay your parts order. Unless another method is specified for item 6, parts weighing less than 150 Lbs. will be shipped United Parcel Service. Parts weighing more than 150 Lbs. will be shipped Motor Freight. Air freight and other transportation services are available but only if specified on your order.

10-4 NAME PLATE INFORMATION

The Name Plate will be located on the Piston Housing (#10). (See below.)

	Force Control Industries, Inc. Fairfield, Ohio
For Service / Parts Call: 513-868-0900	
Posistop® Brake	Model No. <input type="text"/>
	Serial No. <input type="text"/>
Use Mobil ATF-210	

Model Number (See next page.) 

Posistop MB-056 Coupler Brake Model Number Information

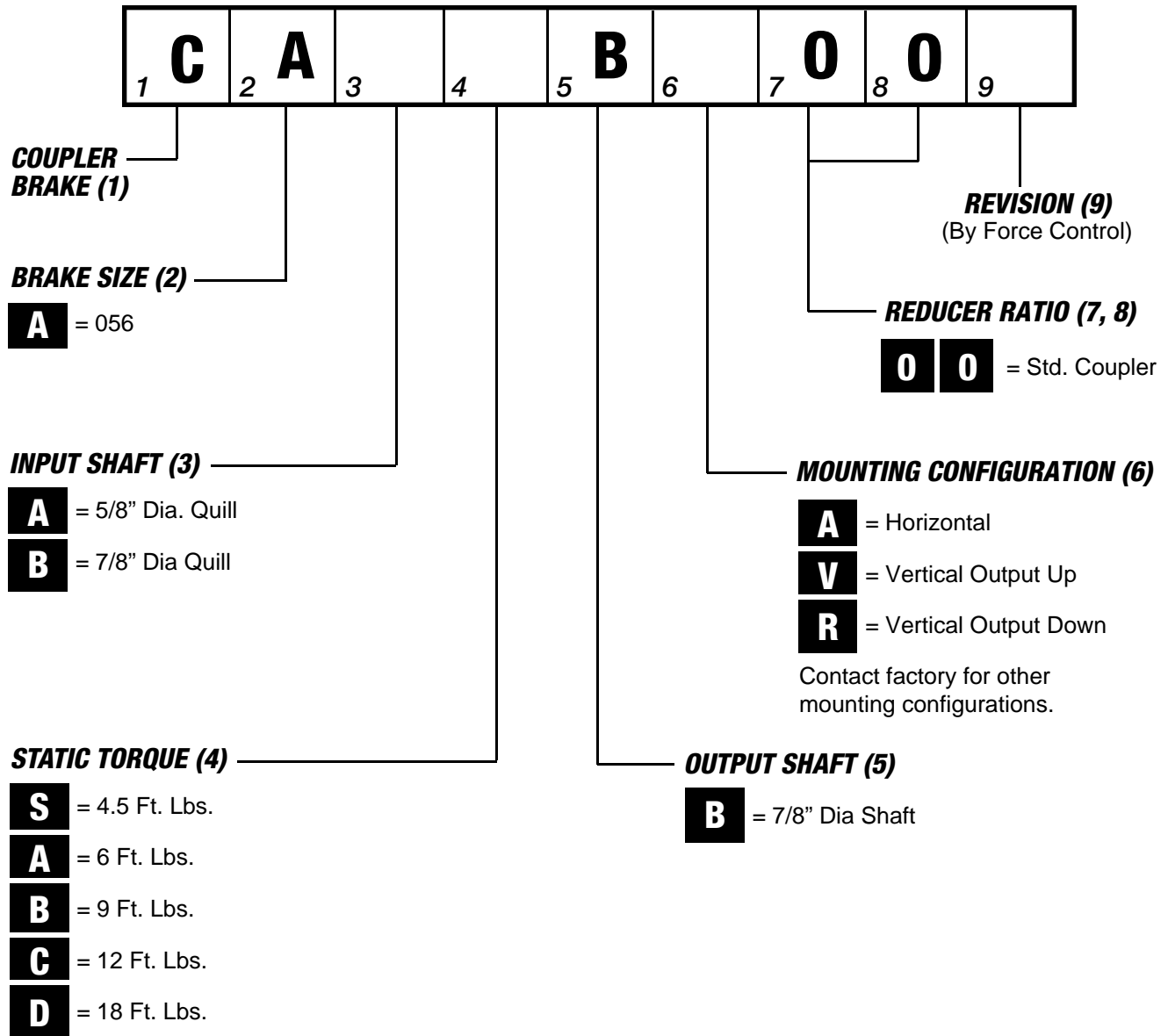

Contact Force Control Industries, Inc. for other Sizes, I.E.C. Mounting and a Complete Drive Package that includes the Drive Motor, Coupler Brake and Gear Reducer.

Repair Parts List for Figures 10.1 & 10.2

Posistop MB-056 Coupler Brake

REF No.	PART NAME	QTY.	REF No.	PART NAME	QTY.
2	Hub	1	*40	O-Ring	2
3	Piston	1	*42	Liner, I.D. Sealing	1
8	Housing	1	*43	Liner, O.D. Sealing	1
9	End Housing	1	**44	Air Breather	1
10	Piston Housing	1	**46	Sight Gauge	1
*12	Friction Plate (Full Brake Stack Only)	1	49	Pipe Plug, 1/2" NPT	1
*13	Drive Disc (Short Brake Stack)	1	50	Pipe Plug, Mag. 1/4" NPT, Sq. Hd.	2
	(Full Brake Stack)	2	*57	Filler Plate (Short Brake Stack Only)	2
*17	Separator Springs (Short Brake Stack)	2	72	Soc. Hd. Cap Screw, 5/16"-18 x 1-3/4" Lg.	4
	(Full Brake Stack)	4	74	Pipe Plug, 1/4" NPT	1
*20	Ball Bearing	1	82	Soc. Set Screw, 3/8'-16 x 5/8" Lg.	4
*31	Oil Seal	1	109	Mounting Spool	4
*32	Wear Sleeve	1	110	Collet, 7/8" Shaft	1
*35	Oil Seal	1	*121	Gasket, Housing	1
*36	Compression Spring (Short Brake Stack)		*122	Gasket, Housing	1
	4.5 Ft. Lbs. Torque	3	127	Lockwasher, 5/16"	9
	6 Ft. Lbs. Torque	4	128	Lockwasher, 3/8"	1
	9 Ft. Lbs. Torque	6	149	Soc. Hd. Cap Screw, 5/16"-18 x 3" Lg. ...	4
	(Full Brake Stack)		150	Hex Hd. Cap Screw, 3/8"-16 x 1-1/4" Lg. .	4
	9 Ft. Lbs. Torque	3	152	Soc. Hd. Cap Screw, 3/8"-16 x 4" Lg.	4
	12 Ft. Lbs. Torque	4	153	Soc. Hd. Cap Screw, 1/4"-20 x 1-1/4" Lg. .	4
	18 Ft. Lbs. Torque	6	158	Dowel Pin, 1/4" Dia. x 3/4" Lg.	4
*38	Friction Plate	2	167	Lockwasher, 1/4"	2
*39	O-Ring	2	176	Dowel Pin, 1/2" Dia. x 1-1/2" Lg.	2
			180	Key	1
			*184	Shim (Short Brake Stack Only)	1

* - Indicates parts in Minor Overhaul Kit.

** - Indicates parts in Major Overhaul Kit. (This Major Overhaul Kit also includes all parts in the Minor Overhaul Kit.)

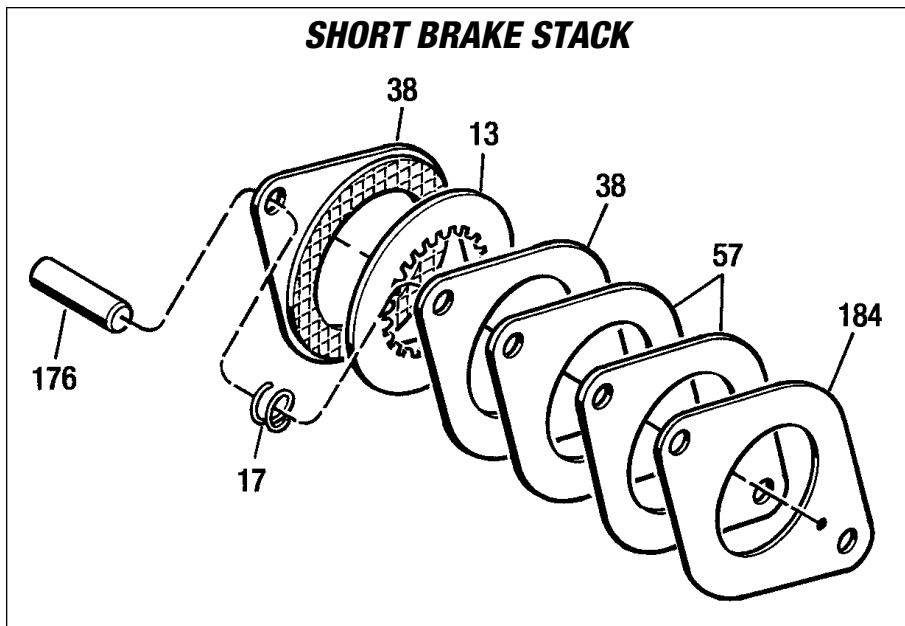

Figure 10.1 - Short Brake Stack

Posistop MB-056 Coupler Brake

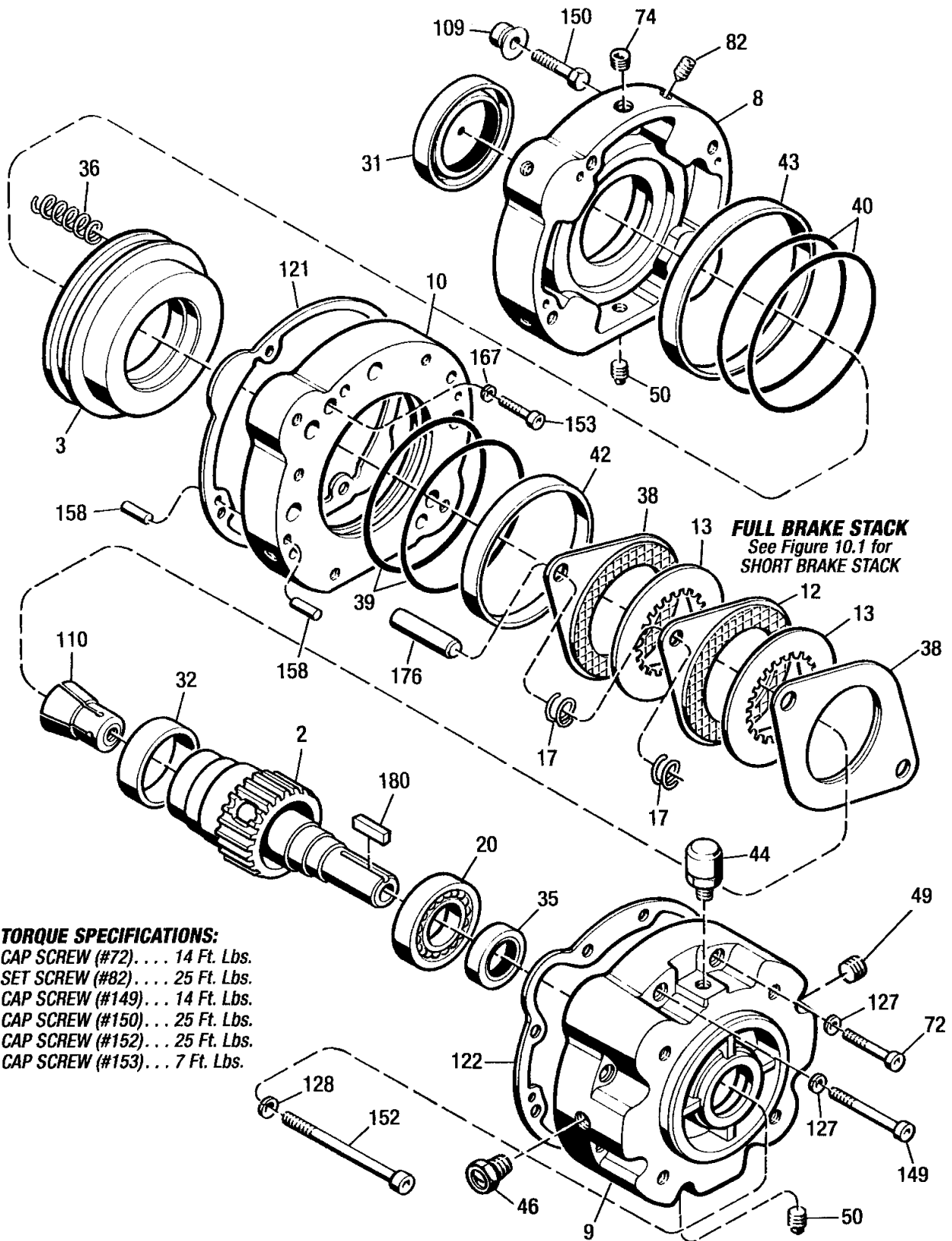

Figure 10.2 - MB-056 Posistop Coupler Brake

Repair Parts List for Figure 10.3
Posistop MB-056 Coupler Brake

REF No.	PART NAME	QTY.	REF No.	PART NAME	QTY.
44	Breather	1	CONTROL VALVE MOUNTING KIT		
46	Sight Gauge (Vertical Up)	1	270	Control Valve	1
49	Pipe Plug, 1/2" NPT	1	271	Mounting Bracket	1
50	Pipe Plug, Mag. Sq. Hd. 1/4" NPT	1	272	Cap Screw, 1/4"-20 x 1-1/2"	2
61	Street Elbow, 1/8" NPT	1	273	Cap Screw, 3/8"-16 x 5-1/2" Lg.	1
66	Street Elbow, 1/4" NPT (Vertical Down) ..	1	274	Lockwasher, 1/4"	2
73	Pipe Plug, 1/4" NPT (Vertical Up)	1	275	Lockwasher, 3/8"	2
	(Vertical Down)	2	276	Hose	1
74	Pipe Plug, 1/4" NPT Sq. Hd. (Vert. Down)	1	277	Hose Fitting	1
75	Pipe Plug, 1/8" NPT (Vertical Up)	1	278	Hose Fitting	1
76	Reducer, 1/4" x 1/8" NPT (Vertical Up) ...	1	280	90° Swivel Fitting	1
95	Reducer, 1/2" x 1/4" NPT (Vertical Down) .	1	281	Street Elbow, 1/8" NPT	1
			282	Muffler	1
			285	Cap Screw, 3/8"-16 x 2" Lg	1

Vertical Installation

Vertical Up Position

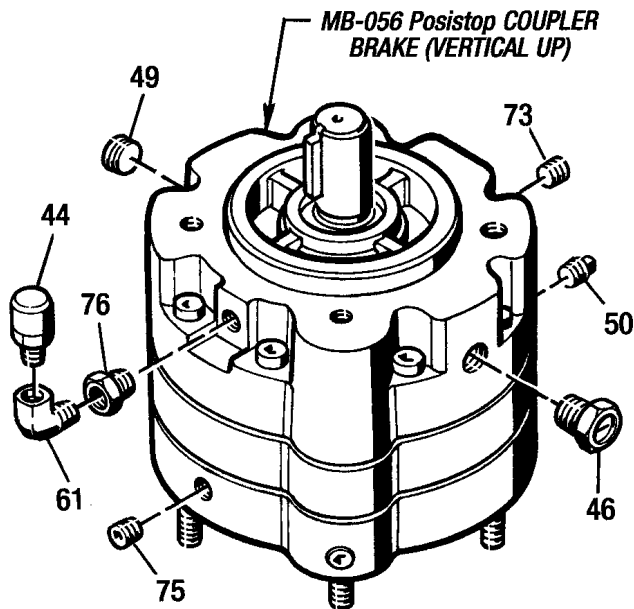

Vertical Down Position

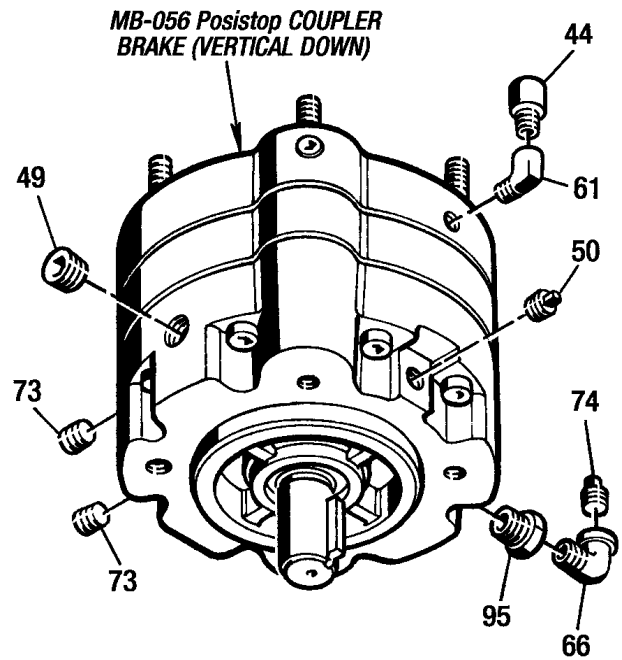

Pneumatic Control Valve Mounting Kit

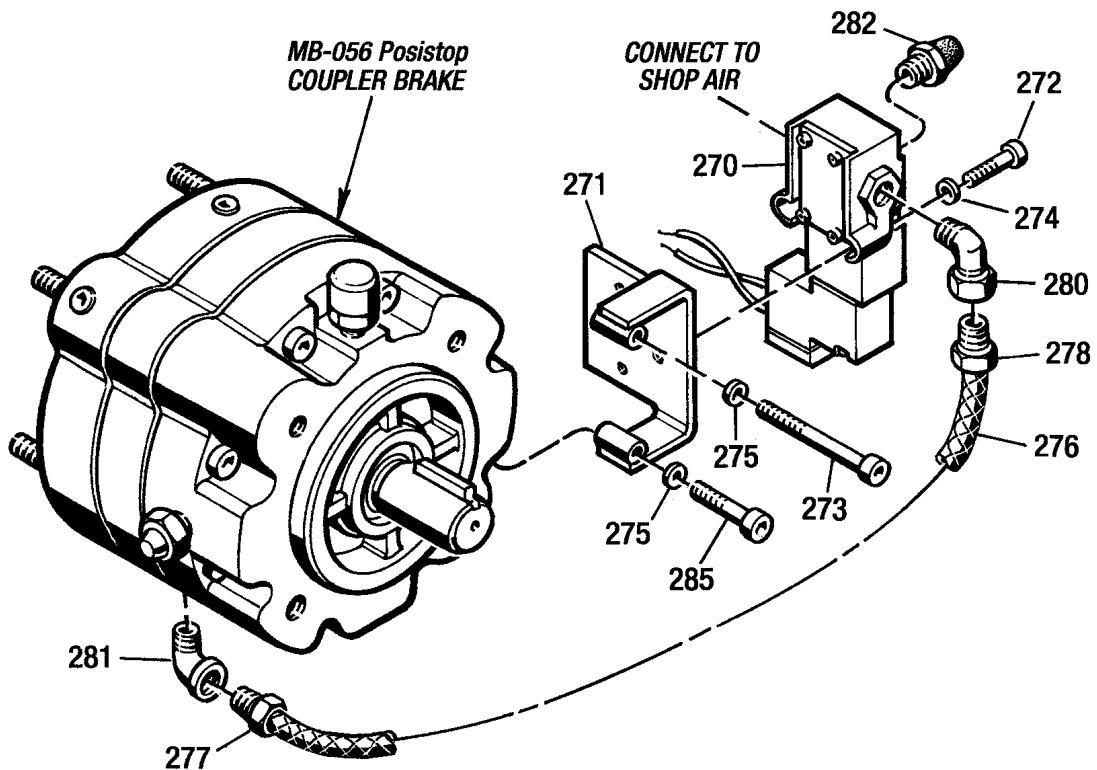

Figure 10.3 - Vertical Installation and Pneumatic Control Valve Mounting Kit

Manual Revision & Printing History

MB-056 Coupler Brake

REVISION NUMBER	REVISION DATE <i>(Mo./Yr.)</i>	PRINTING DATE <i>(Mo./Yr.)</i>	REVISION/ACTION DESCRIPTION	REVISION INITIATED BY: <i>(Name)</i>	REVISION MADE BY: <i>(Name)</i>
502-CB-056-01	2/03	-----	Updated manual format. New cover and back. Added Warranty information. Added Motor Specs. Verification information in Section 3 - Installation.	Yater	Brooks
	-----	3/03	Printed	-----	-----
	1/03	-----	Added Revision History. Minimized all image file sizes and created a new PDF file for the Web. Copied all source files to Windows environment on network.	Brooks	Brooks
502-CB-056-02	12/05	12/05	Removed P.O. Box Number from back cover page.	Brooks	Brooks

FORCE CONTROL INDUSTRIES, INC.

Worldwide Leader in "Oil Shear" Technology

*Providing today's industries
with Oil Shear Clutch and
Brake Drives that delivers:
Flexibility • Efficiency
Endurance • Performance
Dependability*

"Built to Last - Guaranteed to Perform"



FORCE CONTROL INDUSTRIES, INC.

MAIN OFFICE

3660 Dixie Highway
Fairfield, Ohio 45014

Tel: (513) 868-0900
Fax: (513) 868-2105

E-Mail: info@forcecontrol.com
Web: www.forcecontrol.com