



502-MSB9-001-02

SERVICE MANUAL

FOR

MSB9 MSB10 MSB12

MagnaShear™

FULLY ELECTRIC

OIL SHEAR MOTOR BRAKE



WARNING - Read this manual before any installation, maintenance or operation.



FORCE CONTROL INDUSTRIES, INC.

MANUFACTURERS OF MECHANICAL AND ELECTRICAL POWER TRANSMISSION EQUIPMENT

Limited Warranty

Force Control Industries, Inc. ("Force Control") warrants its products to be free from defects in material and workmanship under normal and proper use for a period of one year from the date of shipment. Any products purchased from Force Control that upon inspection at Force Control's factory prove to be defective as a result of normal use during the one year period will be repaired or replaced (at Force Controls'option) without any charge for parts or labor. This limited warranty shall be void in regard to (1) any product or part thereof which has been altered or repaired by a buyer without Force Control's previous written consent or (2) any product or part thereof that has been subjected to unusual electrical, physical or mechanical stress, or upon which the original identification marks have been removed or altered. Transportation charges for shipping any product or part thereof that the buyer claims is covered by this limited warranty shall be paid by the buyer. If Force Control determines that any product or part thereof should be repaired or replaced under the terms of this limited warranty it will pay for shipping the repaired or replaced product or part thereof back to the buyer. EXCEPT FOR THE EXPRESS WARRANTY SET OUT ABOVE, FORCE CONTROL DOES NOT GRANT ANY WARRANTIES EITHER EXPRESSED OR IMPLIED, INCLUDING IMPLIED WARRANTIES OF MERCHANTABILITY OR FITNESS FOR USE. The warranty obligation set forth above is in lieu of all obligations or liabilities of Force Control for any damages. Force Control specifically shall not be liable for any costs incurred by the buyer in disconnecting or re-installing any product or part thereof repaired or replace under the limited warranty set out above. FORCE CONTROL EXPRESSLY EXCLUDES ALL LIABILITY FOR ANY INDIRECT OR CONSEQUENTIAL DAMAGES THE BUYER MAY SUSTAIN IN CONNECTION WITH THE DELIVERY, USE, OR PERFORMANCE OF FORCE CONTROL PRODUCTS. Under no circumstances shall any liability for which Force Control is held responsible exceed the selling price to the buyer of the Force Control products that are proven to be defective. This limited warranty may be modified only in writing signed by a duly authorized officer of the company. This limited warranty applies exclusively to Force Control products; warranties for motors and gear reducers and other component parts may be provided by their respective manufactures. Any legal action for breach of any Force Control warranty must be commenced within one year of the date on which the breach is or should have been discovered.

A Return Goods Authorization (RGA) number must be obtained from the factory and clearly marked on the outside of the package before any equipment will be accepted for warranty work. Force Control will pay the shipping costs of returning the owner parts that are covered by warranty.

Force Control believes that the information in this document is accurate. The document has been carefully reviewed for technical accuracy. In the event that technical or typographical errors exist, Force Control reserves the right to make changes to subsequent editions of this document without prior notice to holders of this edition. The reader should consult Force Control if errors are suspected. In no event shall Force Control be liable for any damages arising out of or related to this document or the information contained in it.



TABLE OF CONTENTS

Section 1 - DESCRIPTION and OPERATION

1-1 UNIT DESCRIPTION.....	1
1-2 THE OIL SHEAR PRINCIPLE.....	1
1-3 OPERATION.....	2

Section 2 - SPECIFICATIONS

2-1 TECHNICAL SPECIFICATIONS.....	3
2-2 DIMENSIONAL SPECIFICATIONS.....	4

Section 3 - INSTALLATION and START-UP

IMPORTANT SAFETY PRECAUTIONS	5
3-1 RECEIVING THE <i>MagnaShear</i> MOTOR BRAKE.....	5
A. Assembled Brake Motor (ABM).....	5
B. <i>MagnaShear</i> Motor Brake.....	5
3-2 SPECIAL ASSEMBLY TOOLS.....	5
3-3 SCREW TORQUE REQUIREMENTS.....	5
3-4 VERIFYING MOTOR SPECIFICATIONS	6
3-5 MOUNTING THE <i>MagnaShear</i> MOTOR BRAKE TO THE DRIVE MOTOR	6
A. Sizes MSB9 and MSB10 Motor Brake	6
B. Size MSB12 Motor Brake	7
3-6 FINAL INSTALLATION.....	8
3-6 WIRING SPECIFICATIONS.....	8
A. Brake Coil	8
B. Brake Release Indicator Switch	9
3-8 START-UP	9

Section 4 - LUBRICATION

4-1 CHECKING THE OIL LEVEL	10
4-2 OPERATING TEMPERATURES.....	10
A. Ambient Temperatures	10
B. Oil Sump Temperature.....	10
4-3 CHANGING THE OIL.....	10
4-4 TYPE OF OIL	10

Section 5 - OPERATIONAL CHECKS

5-1 CHECKING THE BRAKE OPERATION	11
5-2 CHECKING THE BRAKE COIL OPERATION.....	11

Section 6 - TROUBLE SHOOTING

6-1 TROUBLE SHOOTING CHART.....	12
6-2 TROUBLE SHOOTING COILS.....	13
(Sizes MSB9 and MSB10 <i>MagnaShear</i> Motor Brake)	
A. Coil Resistance Check.....	13
B. Coil Current Leakage Test.....	13
(Sizes MSB12 <i>MagnaShear</i> Motor Brake)	
A. Coil Resistance Check.....	14
B. Coil Current Leakage Test.....	14

Section 7 - REPAIR and REPLACEMENT

7-1 GENERAL INFORMATION	15
Tips For Handling Circuit Board.....	15
7-2 CLEANING AND INSPECTION	15
7-3 REPAIR OR REPLACEMENT.....	15
7-4 MEASURING STACK HEIGHT	15
7-5 REPLACING BRAKE STACK	16
A. General Instructions For All Sizes.....	16
B. Sizes MSB9 and MSB10 Motor Brake	16
C. Size MSB12 Motor Brake.....	16
7-6 REPLACING CIRCUIT BOARD	17
A. Sizes MSB9 and MSB10 Motor Brake	17
B. Size MSB12 Motor Brake	17
7-7 REPLACING HOLDING COIL	18
A. Disassembly	18
B. Reassembly	19
7-8 REPLACING WEAR SLEEVE (#32).....	20
A. Removing Hub (#2) From the Motor Shaft	20
B. Removing Wear Sleeve (#32).....	20
C. Installing Wear Sleeve	20
7-9 REPLACING OIL SEAL (#31)	22
7-10 REPLACING BRAKE INDICATOR SWITCH (#249).....	22
7-11 BRAKE REASSEMBLY PROCEDURE.....	23

Section 8 - ILLUSTRATED REPAIR PARTS

8-1 GENERAL INFORMATION	24
8-2 DRIVE MOTORS	24
8-3 FACTORY REBUILD SERVICE.....	24
8-4 ORDERING REPLACEMENT PARTS.....	24
8-5 NAME PLATE AND MODEL NUMBER.....	25

REPAIR PARTS

Parts List for <i>Figure 8.1</i>	26
<i>Figure 8.1</i> - MSB9 and MSB10 <i>MagnaShear</i> Motor Brake	27
Parts List for <i>Figure 8.2</i>	28
<i>Figure 8.2</i> - MSB12 <i>MagnaShear</i> Motor Brake.....	29
Parts List for <i>Figure 8.3</i>	30
<i>Figure 8.3</i> - Brake Coil Circuit Board and Junction Box	31
Parts List for <i>Figure 8.4</i>	32
<i>Figure 8.4</i> - Brake Release Indicator Switch	32
Manual Revision & Printing History	33

Section 1

DESCRIPTION and OPERATION

1-1 UNIT DESCRIPTION

Large **MagnaShear Fully Electric Motor Brakes** with Oil Shear dependability are available in three sizes which have NEMA standard mounting flanges from 10-1/2" FAK to 16" FAK. Spring set torque ratings range from 325 Ft. Lbs to 1250 Ft. Lbs.

A spring set brake stack is released when 120/230 VAC power is supplied to the Brake. Control logic is made simple by use of the motor starter auxiliary contactors. Back EMF effect from the motor windings is eliminated.

The units are ideal for a wide variety of applications including winches, transfer conveyors and other heavy duty start/stop devices. Applications requiring the brake to be released on an average of more than 50% of the time or for long durations must be reviewed and approved by our engineering department.

1-2 The OIL SHEAR PRINCIPLE

Conventional brakes depend on the friction between solid surfaces operating in air to transmit torque. Friction does the job but produces a great amount of heat and wear. The MagnaShear Motor Brake is an Oil Shear Brake, with the friction surfaces operating in a constantly replenished film of oil. The oil molecules cling to each other and to the friction surfaces. As moving and stationary elements are brought together, a thin but positive film of oil is maintained between them which is controlled by the clamping pressure and carefully designed grooves in the friction discs. Torque is transmitted from one element to the other through the viscous shear of the oil film. As long as there is relative motion between the elements, they are protected by the oil, thus greatly reducing wear. The replenished oil film also effectively transmits heat away from the friction elements.

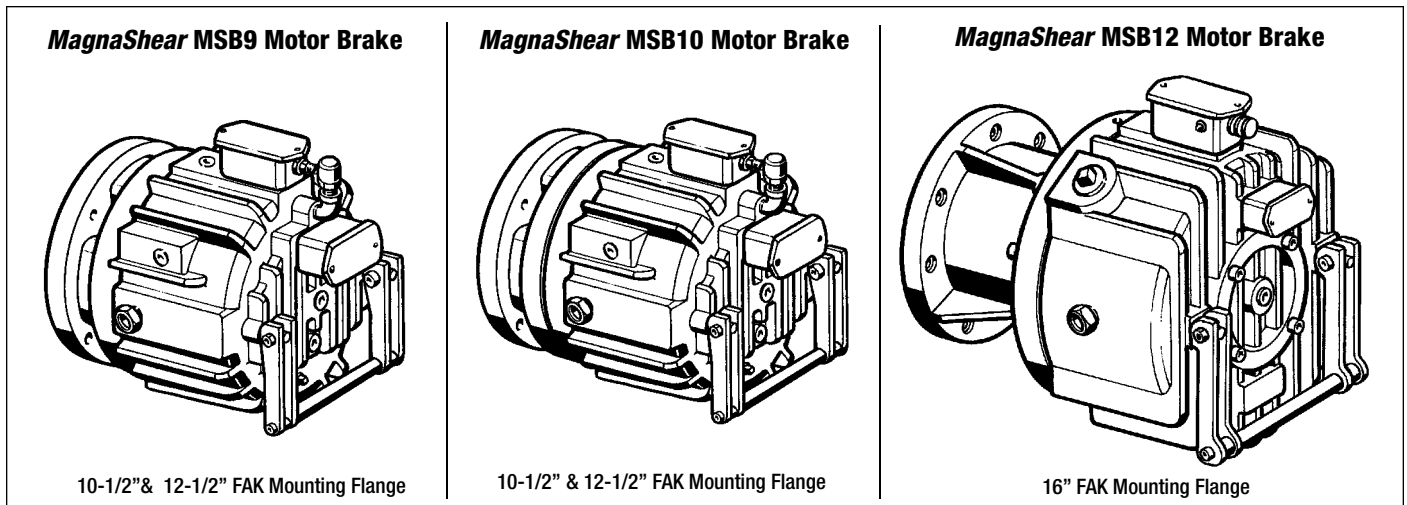
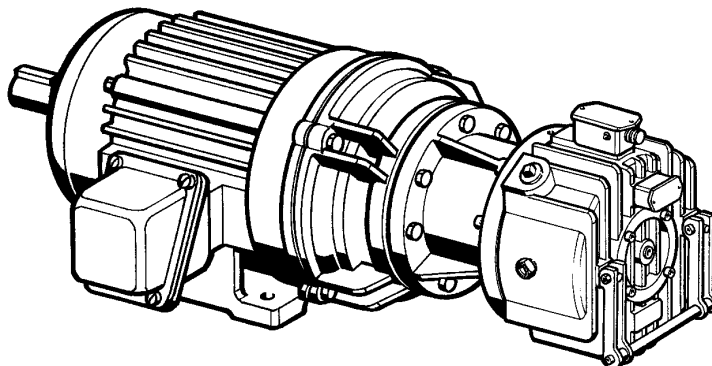

Figure 1.1 - MagnaShear Motor Brakes with C-Face Mounting



The Large **MagnaShear Motor Brake** is also available as an **Assembled Brake Motor (ABM)** in a wide variety of sizes.

1-3 OPERATION

The cross section in *Figure 1.2* shows the **MagnaShear Motor Brake** in the Stopped position with the brake stack engaged. The **MagnaShear Motor Brake** will default to this position when all power is lost.

To run the Drive Motor the Brake Coil is energized, pulling the Armature Plate Assembly away from the

Brake Stack which allows the splined hub and drive motor to rotate independently from the motor brake.

To stop the Drive Motor the Brake Coil is de-energized. This allows the brake springs to push the Armature Plate Assembly against the Brake Stack, clamping it and stopping the splined hub and drive motor.

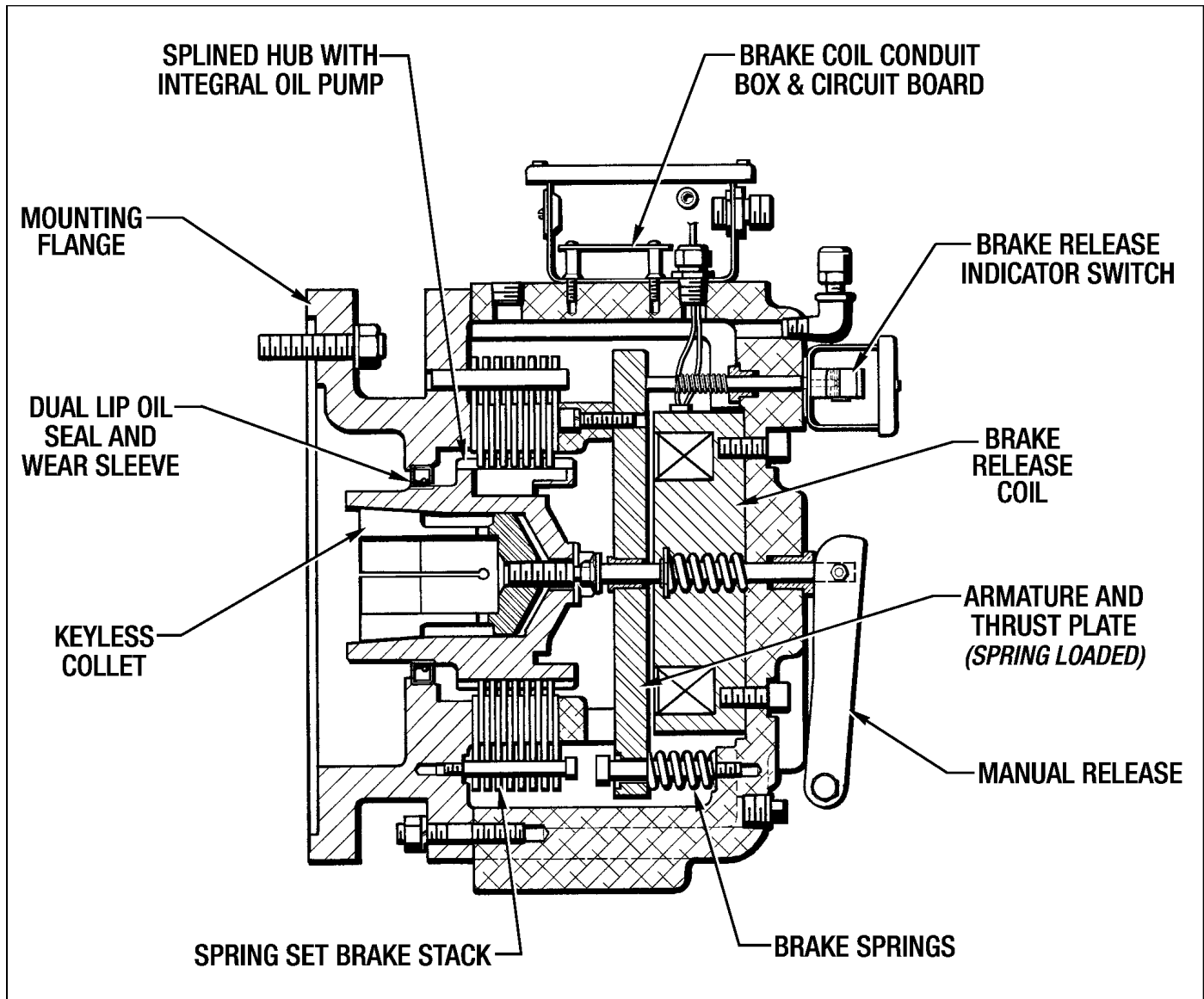

Figure 1.2 - MagnaShear Motor Brake Cross Section

Section 2 SPECIFICATIONS

2-1 Technical Specifications (With Pulse Width Modulation "PWM")

BRAKE SIZE	AVAILABLE PILOT DIA. (Inches)	MAX COLLET BORE (Inches)	No. OF SPRINGS	STATIC TORQUE (Lb. Ft.)	DYNAMIC TORQUE (Lb. Ft.)	MAX. KE per ENGMT. (Ft. Lbs.)	INERTIA (Lb. Ft. ²)	OIL CAP. (Qts.)	INPUT VOLTAGE (VAC)	INRUSH CURRENT (Amps)	HOLDING CURRENT (Amps)	IN RUSH TIME (Sec.)	COIL RESISTANCE @ 20° C. (Ohms)
MSB9	10.50 ----- 12.50	2.375	4	325	280	48,000	0.992	3	115 ----- 230	6	1.8	0.44	21.5 ----- 86
			6	488	420					3	.9		
			8	650	559								
MSB10	10.50 ----- 12.50	2.375	4	450	387	69,000	1.244	3	115 ----- 230	6	1.8	0.44	21.5 ----- 86
			6	675	581					3	.9		
			8	900	774								
MSB12	16.00	3.625	4	625	538	158,000	2.068	12	115 ----- 230	8	2.5	1.4	15 ----- 60
			6	938	807					4	1.3		
			8	1250	1075								

Minimum Collet Bore For Given Static Torque

BRAKE SIZE	GIVEN STATIC TORQUE (Lb. Ft.)	MINIMUM COLLET BORE (Inches)
MSB9	325	1.625
	488	1.875
	650	2.375
MSB10	450	1.625
	675	1.875
	900	2.375
MSB12	625	2.125
	938	2.125
	1250	2.375

Motor Brake Weight

BRAKE SIZE	WEIGHT (Lbs.)
MSB9	250
MSB10	270
MSB12	600

2-2 Dimensional Specifications

MSB9 and MSB10 MagnaShear Brake Dimensions (Inches)

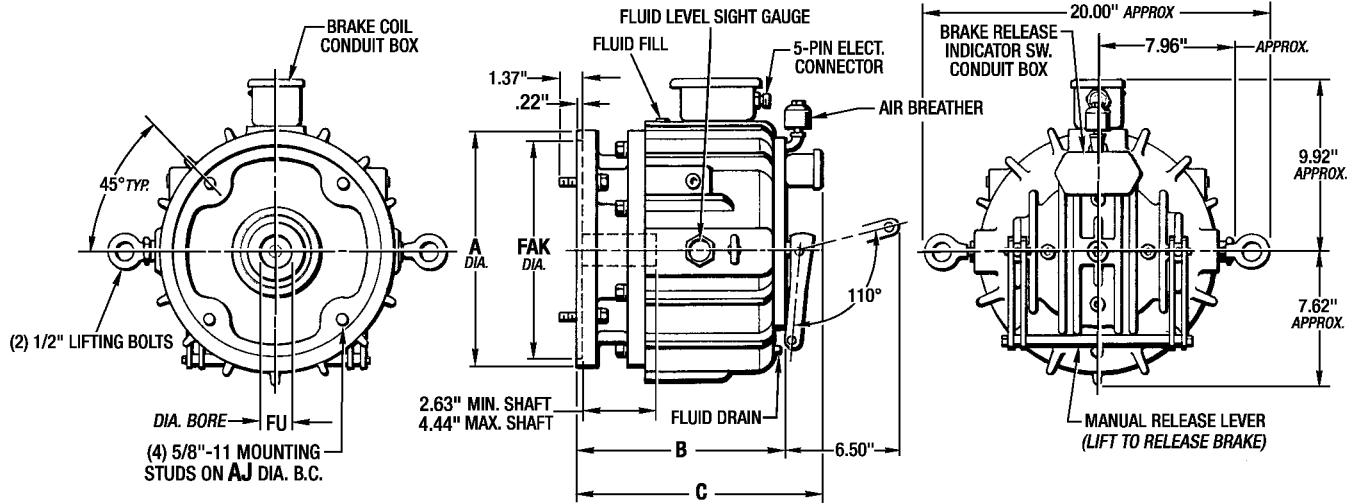

BRAKE SIZE	AVAILABLE FU	FAK	AJ	A	B	C
MSB9	1.625	10.500	9.000	11.75	12.06	14.32
	1.875					
	2.125					
	2.375					
MSB10	1.625	10.500	9.000	11.75	12.91	15.17
	1.875					
	2.125					
	2.375					

STANDARD MOTOR REGISTER TOLERANCES
 10-1 1/2" AK (+.000" -.003")
 12-1 1/2" AK (+.000" -.005")
 16" AK (+.000" -.005")

STANDARD MOTOR SHAFT DIAMETER TOLERANCES
 (+.000" -.001")

MSB12 MagnaShear Brake Dimensions (Inches)

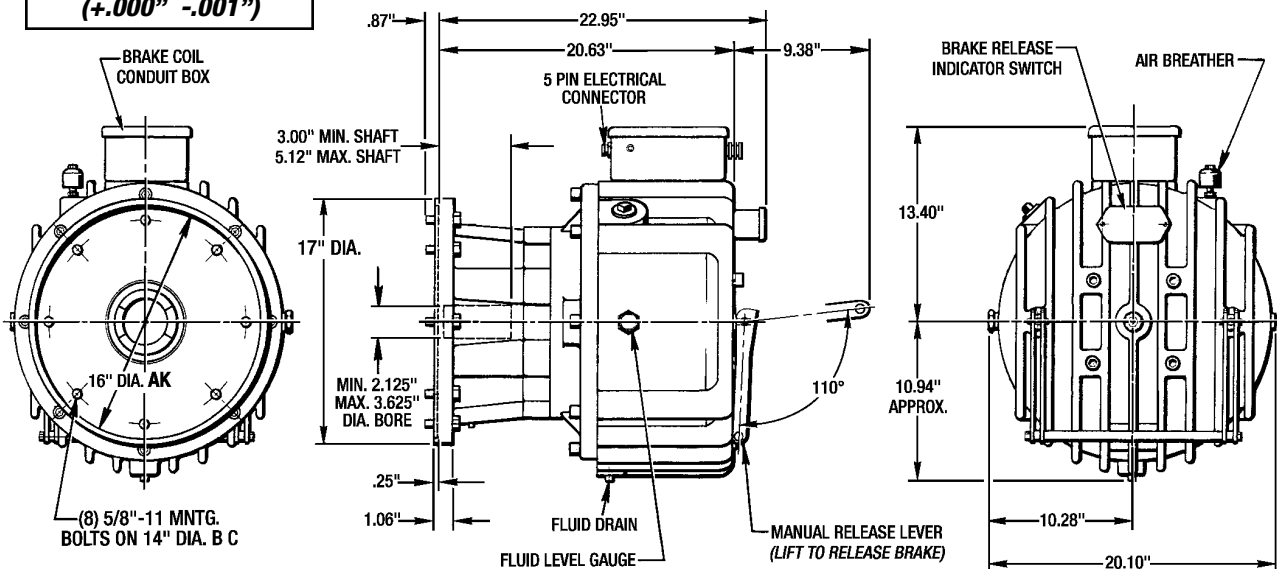

Dimensions are subject to change without notice. Certified Installation Drawings are available upon request.

Section 3 INSTALLATION

IMPORTANT SAFETY PRECAUTIONS

The *MagnaShear* Motor Brake units described in this manual must not be installed in any manner except as specified and must not be operated at speeds, horsepower loads or temperatures other than those specified in this manual.

Failure to limit the operation of the drive to the conditions specified could damage the unit or damage interconnected equipment and void the Warranty.

WARNING

BEFORE INSTALLATION OR ATTEMPTING ANY REPAIRS TO THE MOTOR BRAKE, OPEN THE DISCONNECTS TO THE DRIVE MOTOR. LOCK IT OUT TO AVOID THE POSSIBILITY OF PERSONAL INJURY.

3-1 RECEIVING THE *MagnaShear* MOTOR BRAKE

Check the brake for shortage or damage immediately upon arrival. Prompt reporting to the carrier's agent, with notations made on the freight bill, will expedite satisfactory adjustment by the carrier. **Force Control is not responsible for damage in shipment.**

A. Assembled Brake Motor (ABM)

If your *MagnaShear* Motor Brake is shipped pre-assembled to a drive motor, it is filled with oil and ready to run except for installing the Air Breather (#45) and electrical wiring. (See Figures 3.7, 3.8 and 3.9 for Electrical Wiring Diagram and information.)

NOTE:

Before shipment, the Air Breather (#45) is removed and a plastic pipe plug put in its place. This is done to prevent oil spillage during shipment. In most cases this will be a red plastic plug. This plug must be removed and the Breather (#45) installed to prevent damage to the brake. The breather is taped to the motor shaft for shipment. Always check the oil level to see if the oil level is in the center of the Sight Gauge (#46). (See Section 4 LUBRICATION)

B. *MagnaShear* Motor Brake

The standard *MagnaShear* Motor Brake has been partially assembled at the factory for ease of shipment. The Motor Brake is completely assembled except for the Hub and Collet Sub-assembly, which is packaged separately and also the motor mounting bolts or studs and lockwashers. Partial disassembly will be necessary to mount the brake to the drive motor.

During Installation refer to Section 8 for a visual reference to parts.

- MSB9 Motor BrakeFigure 8.1
- MSB10 Motor BrakeFigure 8.1
- MSB12 Motor BrakeFigure 8.2
- Electric Box & Circuit BoardFigure 8.3
- Brake Release Indicator SwitchFigure 8.4

3-2 SPECIAL ASSEMBLY TOOLS

(2) Guide Pins (#12) are required for the MSB9 & MSB10 while (4) Guide Pins (#901) are required for the MSB12 to install the Brake Stack. A Hub Holding Tool (#900) is required to torque the Collet Locking Bolt. The Tools and Part Ref. Numbers are shown in the following Figure 3.1. These tools are supplied but spares or replacement tools can be ordered from Force Control with their given part number. (See Figures 8.1 and 8.2)

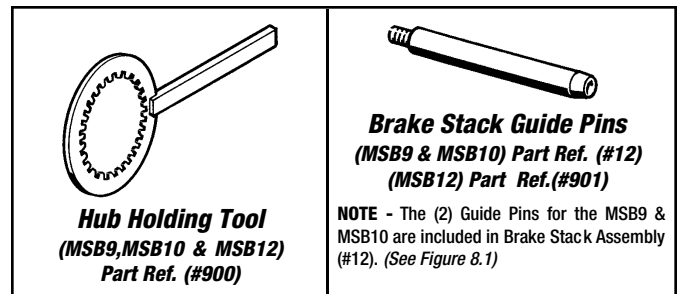

Figure 3.1 - Special Assembly Tools

3-3 SCREW TORQUE REQUIREMENTS

- 1/4"-207 Lb. Ft.
- 5/16"-1814 Lb. Ft.
- 3/8"-1625 Lb. Ft.
- 7/16"-1440 Lb. Ft.
- 1/2"-1360 Lb. Ft.
- 5/8"-11120 Lb. Ft.
- 3/4"-10200 Lb. Ft.
- 7/8"-9302 Lb. Ft.

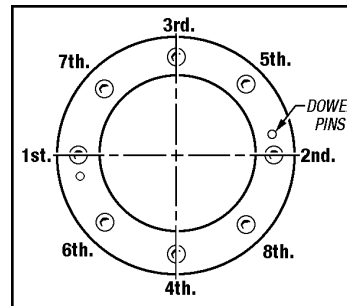

Figure 3.2 - Torque Pattern Example

It is **very important** that all screws are torqued with a torque wrench to the specified torque. Also torque screws in an opposite 180° pattern as shown in the Example Figure 3.2. Start with the screws nearest the locating dowel pins.

3-4 VERIFYING MOTOR SPECIFICATIONS

The **Motor Manufacturer's Specifications** must be verified first to ensure the Motor Brake Oil Seal Reliability. (1) **Motor Shaft Runout**, (2) **Mounting Face Runout** and (3) **Motor Shaft to Pilot Diameter Eccentricity** need to be checked with a Dial Indicator as shown in *Figure 3.3*.

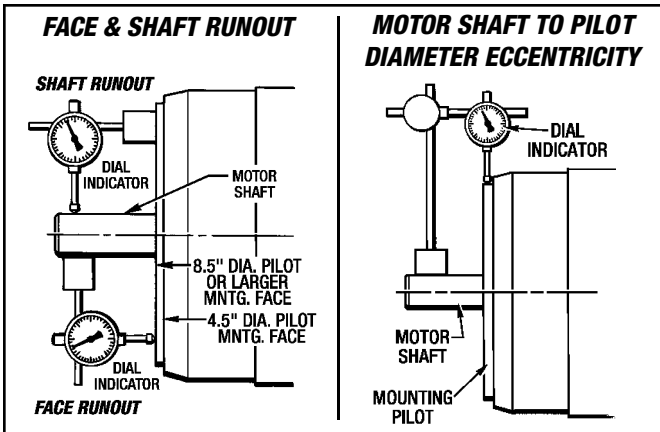

Figure 3.3 - Verifying Motor Specifications

MAXIMUM ALLOWABLE T.I.R. (Inches) (As Per NEMA MG 1 Standard)

Pilot Dia. Dimensions	Tolerance On Pilot Dia.		Maximum Allowable Shaft Runout	Maximum Allowable Face Runout	Maximum Allowable Eccentricity
	Plus	Minus			
Less than 12"	.000	.003	.002	.004	.004
12" & Larger	.000	.005	.003	.007	.007

CAUTION - T.I.R. in excess of this maximum will result in a potential leak condition.

3-5 MOUNTING THE *MagnaShear* MOTOR BRAKE TO THE DRIVE MOTOR

First check the motor shaft and pilot diameter for any nicks, scratches or burrs. Clean-up and de-burr if necessary. Degrease motor shaft, Collet (#110) & Hub (#2).

IMPORTANT - Do not use any Molybdenum Disulfide "MOLYKOTE" or any other similar lubricant on the motor shaft. The collet locking element is keyless and depends on friction to transmit torque from the brake to the motor shaft.

A. Sizes MSB9 and MSB10 Motor Brake

(See Figure 8.1)

1. Pull up the Manual Release Lever to release the brake.
2. Remove the End Housing (#9) from the Mounting Flange (#8) by taking off the (8) Hex Nuts (#261) and (8) Lockwashers (#127). Pull the End Housing (#9) away from the Mounting Flange (#8).
3. Remove the Brake Stack (#12) from the Mounting Flange (#8) by unscrewing the (2) Shoulder Bolts in the Drive Plates. The (2) Guide Pins (#12) remain.

4. Set the Brake Stack (#12) on a work bench with the threads of the (2) Shoulder Bolts pointing up. There is a Retaining Ring on each Shoulder Bolt. Remove both of them and discard them.

IMPORTANT - Make sure you keep the Brake Stack in exactly the same order as they were assembled. There are (2) Separator Springs between each Drive Plate. Be careful not to lose track of them.

5. Screw the (4) Studs (#155) in to the motor mounting face. Leave approximately 1-5/8" of exposed thread from the motor face. **Use Blue Loctite #242.**
6. Attach the Mounting Flange (#8) to the motor mounting face with the (4) Hex Nuts (#392) and (4) Lockwashers (#168). **Torque to 120 Lb. Ft.**
7. Apply a light coat of White Grease or equivalent to the Wear Sleeve (#32) located on the Hub (#2) and the lip of the Oil Seal (#31) located in the Mounting Flange (#8).
8. Slide the Hub (#2) and Collet (#110) onto the motor shaft, being. **Be careful not to damage the lip of the Oil Seal (#31) or Wear Sleeve (#32).**
9. Position the Hub (#2) as shown in *Figure 3.4*. Measure the distance from the end of the Hub (#2) to the face of the Mounting Flange (#8). This distance should be **2.50" + 1/32"** for the MSB9 and **3.25" + 1/32"** for the MSB10. Apply **Blue Loctite #242** and tighten the Collet Locking Bolt (#94) enough to take out excess clearance in the Hub/Collet Assembly but still able to move it.

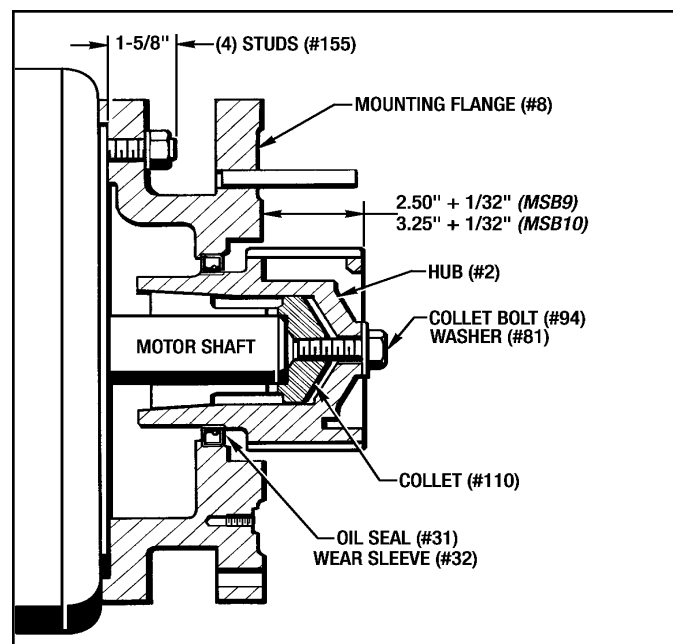

Figure 3.4 - Installing Mounting Flange (#8) and Positioning The Hub (#2) and Collet (#110) on The Motor Shaft

- Use the Hub Holding Tool (#900) to hold the Hub (#2). Torque the Collet Locking Bolt (#94) to **190 Lb. Ft.** for the **MSB9** and **324 Lb. Ft.** for the **MSB10**.

NOTE: The Hub (#2) will move approx. 1/32" further on to the shaft as the screw is tightened. The final position of the Hub (#2) is $\pm 1/64$ "

Installing Brake Stack

- If needed, install the (2) Guide Pins (#12) 180° apart into the Mounting Flange (#8) as shown in *Figure 3.5*. Use **Blue Loctite #242**.

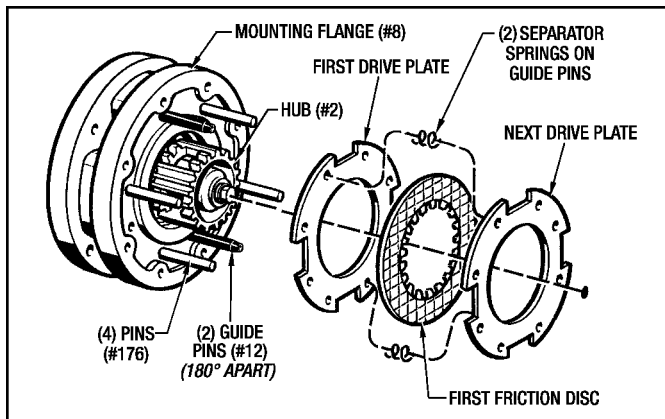

Figure 3.5 - Installing The MSB9 & 10 Brake Stack (#12)

- Take the First Drive Plate from the Brake Stack (#12) and place it over the (4) Pins (#176) and the (2) Guide Pins (#12).
- Place the First Friction Disc on the Hub (#2) spline.
- Place a Separator Spring on each Guide Pin.
- Repeat Steps 12, 13 and 14 until all Drive Plates, Friction Discs and Separator Springs have been installed, ending with a Drive Plate.
- Install the (2) Shoulder Bolts (#12), using **Blue Loctite #242**, thru the two remaining holes in the Drive Plates (#12) into the Mounting Flange (#8).
- Torque all (4) Shoulder Bolts to **14 Lb. Ft.**
- Place the Gasket (#121) on the mounting face of the End Housing (#9).
- Slide the End Housing (#9) into place and attach with (8) Lockwashers (#127) and (8) Hex Nuts (#261). Torque these (8) Hex Nuts (#261) to **60 Lb. Ft.**

NOTE: There will be an extra Gasket (#121) and a Spacer (#60) between the End Housing (#9) and the Mounting Flange (#8) for Size MSB10.

- Lower the Manual Release Lever to engage the brake.

B. Size MSB12 Motor Brake

(See *Figure 8.2*)

- Pull up the Manual Release Lever to release the brake.
- Remove the End Housing (#9) from the Housing (#8) by taking out the (8) Screws (#148) and (8) Lockwashers (#127). Pull the End Housing (#9) away from the Housing (#8).
- Remove the Gasket (#122) and keep it for reassembly.
- Remove the whole Brake Stack from the Housing (#8) by unscrewing the (4) Shoulder Bolts (#138) in the Drive Plates (#12). **Do not remove these (4) Shoulder Bolts (#138) from the Brake Stack.**
- Set the Brake Stack on a work bench with the threads of the (4) Shoulder Bolts (#138) pointing up.

IMPORTANT - Make sure you keep the Brake Stack in exactly the same order as they were assembled. There are (2) Separator Springs (#17) between each Drive Plate (#12). Be careful so not to lose track of them.

- Attach the Motor Adapter Housing (#7) and Housing (#8) to the motor mounting face with the (8) Hex Hd. Screws (#166) and (8) Lockwashers (#168). **Torque to 120 Lb. Ft.**
- Apply a light coat of White Grease or equivalent to the Wear Sleeve (#32) located on the Hub (#2) and the lip of the Oil Seal (#31) located in the Motor Adapter Housing (#7).
- Slide the Hub (#2) and Collet (#110) onto the motor shaft. **Be very careful not to damage the lip of the Oil Seal (#31) or Wear Sleeve (#32).**
- Position the Hub (#2) as shown in *Figure 3.6*. Measure the distance from the end of the Hub (#2) to the face of the Motor Adapter Housing (#7). This distance should be **3.37" + 1/32"**. (*Figure 3.6 is on the next page*)

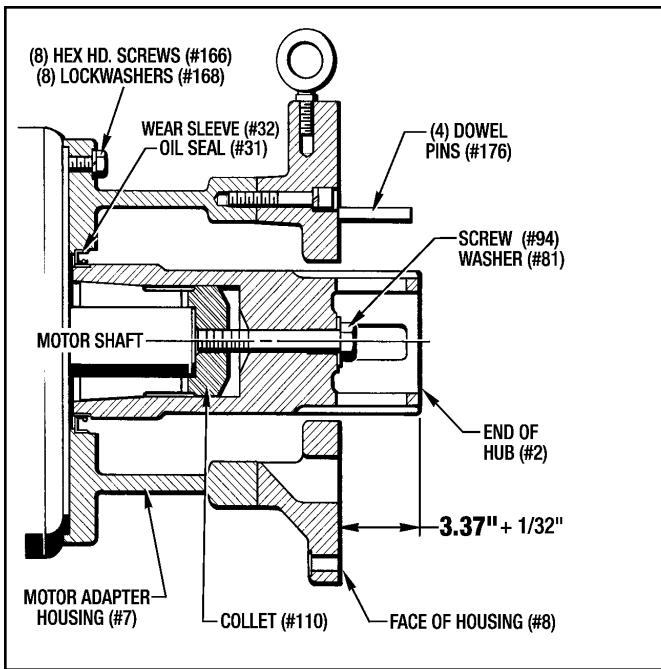

Figure 3.6 - Installing Motor Adapter Housing (#7) and Positioning The Hub (#2) and Collet (#110) on The Motor Shaft

10. Use the **Hub Holding Tool (#900)** to hold the Hub (#2). Apply **Blue Loctite #242** and torque the Collet Locking Bolt (#94) to **515 Lb. Ft.**

NOTE: The Hub (#2) will move approx. 1/32" further on to the shaft as the screw is tightened. The final position of the Hub (#2) is $\pm 1/64$ ".

Installing Brake Stack

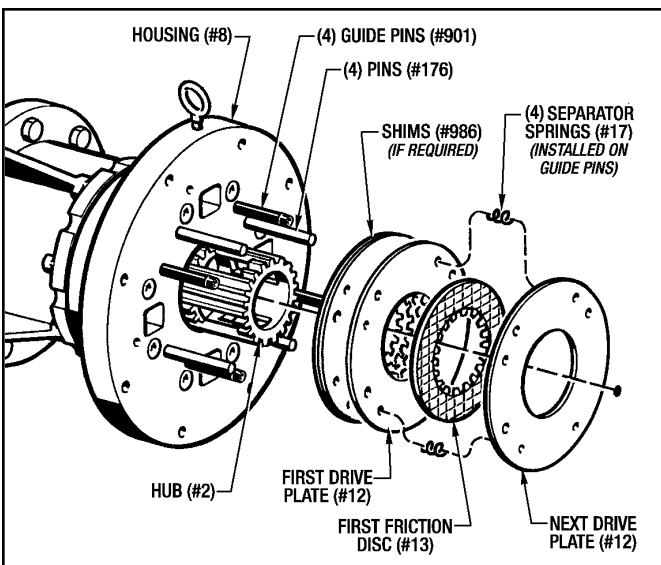

Figure 3.7 - Installing MSB12 Brake Stack

11. Remove the (4) Guide Pins (#901) from the stored position (See Figure 8.2) and install them into the Housing (#8) as shown in Figure 3.7.

12. If any Shims (#986) were required, install them first.
13. Take the First Drive Plate (#12) from the Brake Stack and place it over the (4) Pins (#176) and the (4) **Guide Pins (#901)**.
14. Place the First Friction Disc (#13) on the Hub (#2) spline.
15. Place a Separator Spring (#17) on each of the (4) **Guide Pins (#901)**.
16. Repeat Steps 12, 13 and 14 until all Drive Plates (#12), Friction Discs (#13) and Separator Springs (#17) have been installed, ending with a Drive Plate (#12).
17. Remove the Guide Pins (#901) one at a time while keeping pressure on the stack with your hand. This will keep the Separator Springs (#17) in place. Replace each of the (4) Guide Pins (#901) with Shoulder Bolts (#138). Use **Blue Loctite #242** on the bolts and torque to **25 Lb. Ft.** Replace the (4) Guide Pins (#901) back into the (4) storage position holes.
18. Insert a couple Lockwashers (#127) and Screws (#149) into the Housing (#8) and position the Gasket (#122) on the face of the Housing (#8).
19. Slide the End Housing (#9) into place and attach with (8) Lockwashers (#127) and (8) Screws (#149).
Torque these (8) Screws (#149) to **120 Lb. Ft.**
20. Lower the Manual Release Lever to engage the brake.

3-6 FINAL INSTALLATION

1. Make sure all pipe plugs, Sight Gauge (#46) and Air Breather (#45) is installed properly in the housings.
2. Remove the Pipe Plug (#73) in the top of the End Housing (#9).
3. Fill the brake unit with fresh oil to the center of the Sight Gauge (#46) as described in **Section 2 - Lubrication.**

3-7 WIRING SPECIFICATIONS

(See Figures 3.8, 3.9 and 3.10)

A. Brake Coil

NOTES:

1. Coils may be driven independently.
2. Circuit Breaker Requirements:

MSB9 & MSB10 - 120 VAC Type #10 AC high in-rush current (Motor Starter) 7 Amp.

MSB12 - 120 VAC Type #10 AC high in-rush current (Motor Starter) 10 Amp.

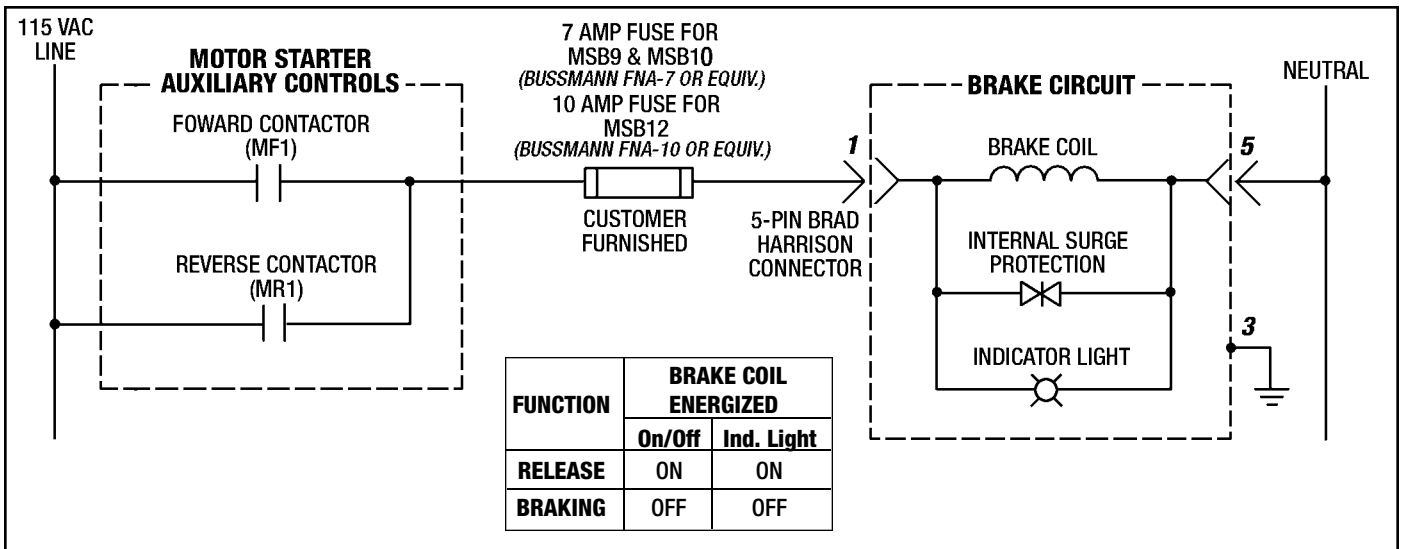

Figure 3.8 - Electrical Schematic

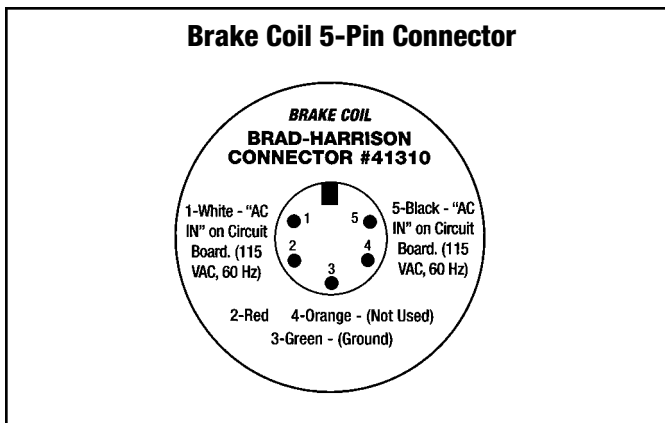

Figure 3.9 - Brad Harrison Connectors

3. Fuse Requirements:

MSB9 & MSB10 - 7 Amp Fuse, (Bussmann FNA-7 or equivalent.)

MSB12 - 10 Amp Fuse, (Bussmann FNA-10 or equivalent.)

B. Brake Release Indicator Switch

(See Figure 3.10)

3-8 START-UP

Verify that the Brake Coil is connected correctly. Check to see if the Drive Motor is wired correctly, fuses are in place and the motor disconnect is turned on. Set-up preliminary settings on positioning switches to insure the brake will stop.

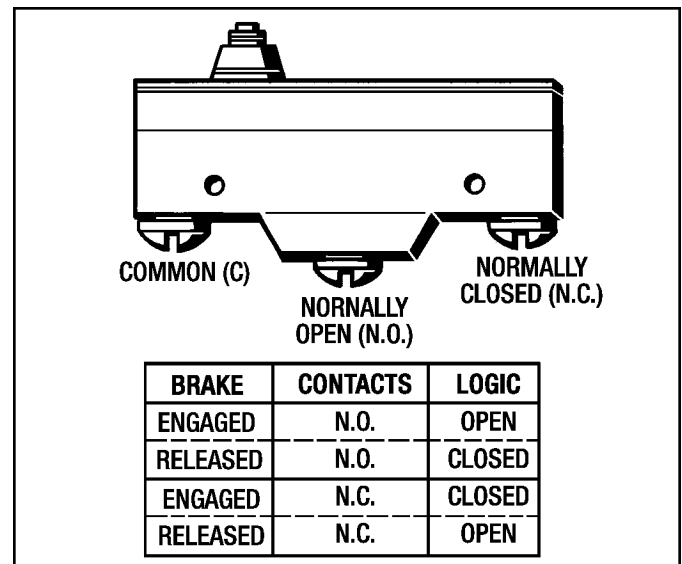

Figure 3.10 - Brake Release Indicator Switch

"Bump" the Drive Motor to check for correct rotation. If the rotation is incorrect change two of the phase wires and recheck rotation. Verify that the Brake Coil Indicator Light on the Conduit Box is ON while the drive motor is running.

Next, complete a cycle to insure that there are no interference problems within the system.

Set-up Position Switches as required.

Section 4 LUBRICATION

4-1 CHECKING THE OIL LEVEL

When the brake is installed and weekly thereafter, or until experience dictates otherwise, check the oil level. Always check the oil level with the brake at room temperature and while Hub is not rotating.

The **MagnaShear Motor Brake** has an Oil Sight Gauge (#46) located on the side of the End Housing. (See *Figure 4.1*). The oil level is to be at the center of the sight gauge with the motor turned off or brake is set.

4-2 OPERATING TEMPERATURES

A. Ambient Temperature

The standard oil used in the **MagnaShear** Brake is designed to operate between 40° F and 125°F. If the ambient temperature will fall outside of this range please contact Force Control Industries, Inc. for specific recommendations on proper lubricant.

B. Oil Sump Temperature

The maximum recommended oil sump temperature is 200° F.

4-3 CHANGING THE OIL

IMPORTANT

Always open the disconnects to the drive motor before changing the oil.

Every three months completely drain the oil from the brake by removing Drain Plug (#64). If the Sight Gauge (#46) becomes dirty, it should also be removed and cleaned.

The oil should be changed more frequently when used in harsh environments or high cyclic applications.

1. Replace the Drain Plugs and Sight Gauge if they were removed.
2. Remove Pipe Plug (#73) at the top of the End Housing (#9). Fill with oil to the center of Sight Gauge (#46). (See *Page 3 for Oil Capacity.*)
3. Replace Pipe Plug (#73).

Do not overfill the brake unit. Excess oil will cause the brake to over heat.

4-4 TYPE OF OIL

Use only Mobil Automatic Transmission Fluid ATF-210 (Type "F") or Mobil Multi-Purpose Automatic Transmission Fluid for most brakes.

Other fluids may be specified for special applications. Consult Force Control factory.

Always use the type of oil specified on the Name Plate.

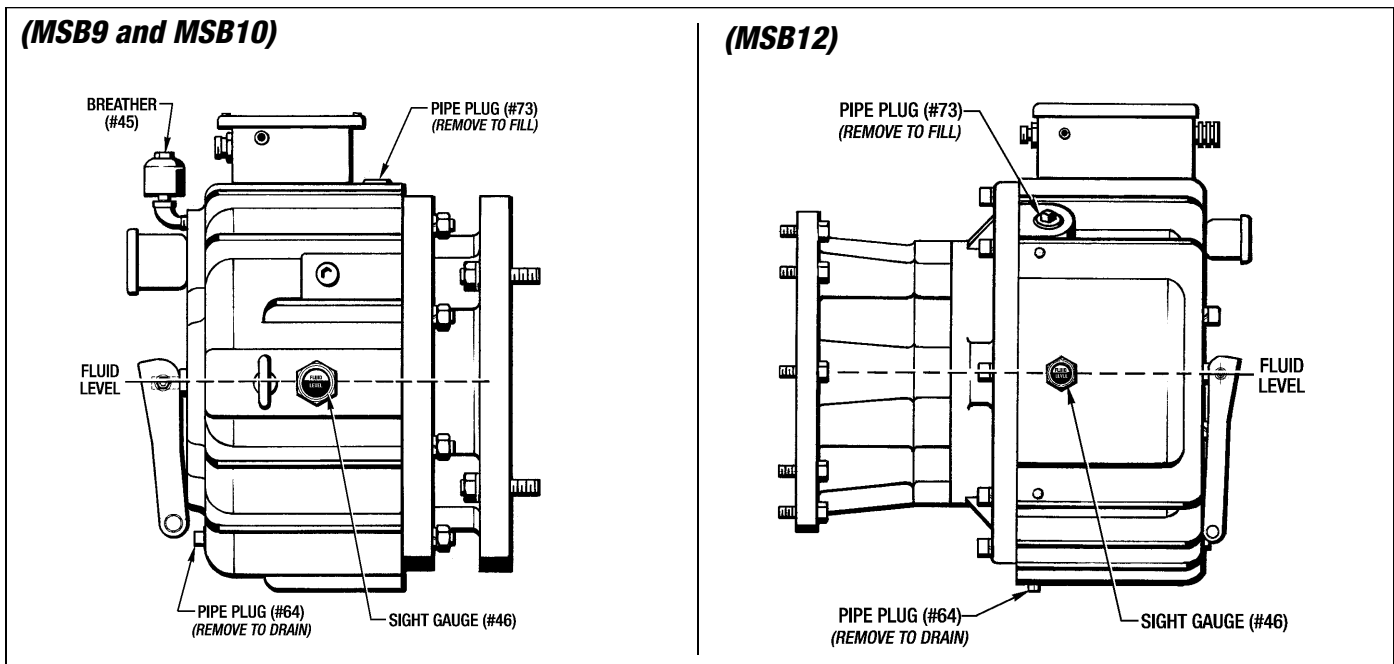

Figure 4.1 - Lubrication - Horizontal Mounting

Section 5 OPERATIONAL CHECKS

Make these Operational Checks with the **MagnaShear Motor Brake** shut down and completely assembled with the drive motor attached.

Provisions for manual operation checks must be made if the drive unit has been removed for service and repair. 120 VAC or 230 VAC, 60 Hz. electrical service is required to release the brake. (See *Figure 5.1* below for the Test Set-Up)

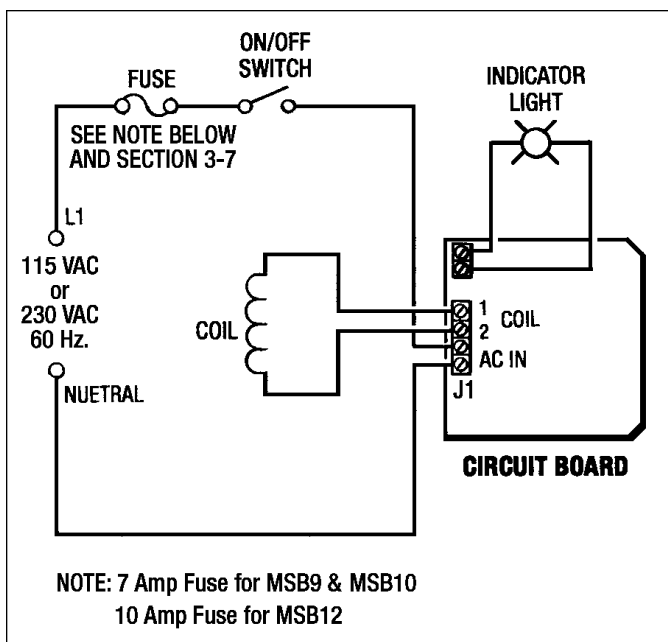

Figure 5.1 - Test Set-Up Electrical Schematic

5-1 CHECKING THE BRAKE OPERATION

To check the Brake Operation electrical power is not required to energize the coil since the **Magna Shear Motor Brake** has a spring applied brake when the coil is de-energized.

Disconnect the load to the motor. Install a torque wrench on the motor shaft and apply torque. The brake should slip at or higher than the static torque rating of the brake. (Refer to page 3 for torque ratings.)

5-2 CHECKING THE BRAKE COIL OPERATION

1. Remove the cover from the Conduit Box (#405).
2. Disconnect the black and white power leads from the Brad-Harrison Cable Connector (# 416) to "AC In" on Terminal Strip J1. located on the Circuit Board (#400).
3. Connect the test power leads to "AC In" on J1. Turn the On/Off Switch to ON. The Power Indicator Light should come on and indicate the brake is released.
4. Manually turn the Drive Motor Output Shaft. If the shaft turns then the Brake Coil and Control Circuit is operating properly.

If it is not able to be turned, then the Brake Coil or Circuit Board is not functioning properly. (See Section 6 Trouble Shooting.)

CAUTION

Physical damage or mal-function in the motor or brake stack can also prohibit shaft rotation.

Section 6 TROUBLESHOOTING

6-1 TROUBLESHOOTING CHART

PROBLEM	POSSIBLE CAUSE	REMEDY
1. Brake fails to engage properly.	Electrical control circuit. Faulty <i>Magna Shear</i> circuit board. Worn friction surfaces.	Check control circuit. Replace circuit board. Check disc stack for wear and replace if necessary.
2. Brake fails to release properly.	Electrical control circuit. Faulty <i>Magna Shear</i> circuit board. Faulty coil. Low voltage at circuit board.	Check control circuit. Replace circuit board. Replace coil. Verify control power.
3. Brake torque too high.	Excessive spring force. Low oil level.	Contact Force Control. Check oil level and add oil. Inspect for oil leak.
4. Brake torque too low	Inadequate spring force./Wrong oil.	Contact Force Control.
5. Noise and vibration	Motor mounted on poor foundation.	Improve installation. Tighten mounting bolts.
6. Drive overheats (200° F max.)	Brake fails to engage or disengage properly. Improper oil level.	See #1 and #2 above. Check oil level. Add/Drain as req'd.
7. Oil leakage.	Worn oil seal. Gaskets. Poor ventilation.	Disassemble and replace. Tighten all external screws. Remove breather and clean.
8. Brake does not repeat. (Inconsistent Stopping.)	Electrical control circuit. Faulty <i>Magna Shear</i> circuit board. * Oil temperature change. Machine resistance changed.	Check control circuit/PLC scantime. Replace circuit board. Check temperature. Lubricate bearings.

* For installations requiring precise starting and stopping, operating temperatures are important. Operating temperatures between 115° F and 165° F are recommended.

6-2 TROUBLESHOOTING COILS

(Sizes MSB9 & MSB10 *MagnaShear Motor Brake*)

Pulse Width Modulation (PWM) Board

A. Coil Resistance Test

Remove the cover from the Junction Box (#405) and disconnect the (2) Coil Leads from both terminals on the Terminal Strip J1 located on the Circuit Board (#400).

Hook-Up a Meg-Ohmmeter to both coil leads as shown in *Figure 6.1*. Set the Meg-Ohmmeter to "Ohm" range and test Resistance at 500 VDC.

The Resistance should read as follows:

MSB9 & 10 Coil Resistance-

115 VAC	21.5 Ohms ± 10%
230 VAC	86 Ohms ± 10 %

A reading outside of this range would indicate that the Coil is bad and needs to be replaced. See **Section 7 for Coil Replacement**.

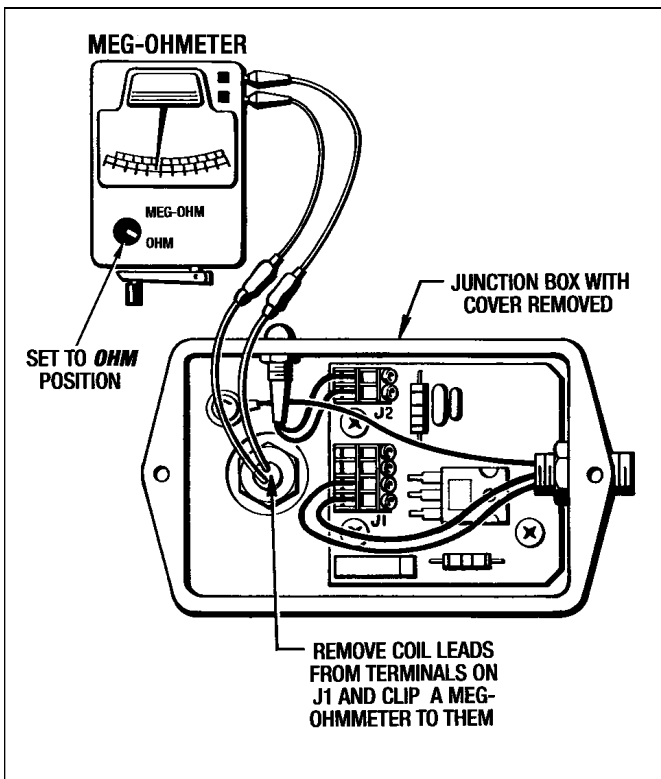

Figure 6.1 - Coil Resistance Testing

NOTE:

A Hi-Pot Tester can be used for this test but do not exceed 1250 VDC.

B. Coil Current Leakage Test

Remove the cover from the Junction Box (#405) and disconnect the (2) Coil Leads from both terminals on the Terminal Strip J1 located on the Circuit Board (#400).

Connect (1) alligator clip to both Coil Leads and the other one to Chassis Ground Screw (#426). (See *Figure 6.2*)

A reading of **10 Meg-Ohms or greater** indicates that the Coil is fine and does not need to be replaced. Anything much less would indicate that there is a short to ground and the Coil would need to be replaced. See **Section 7 for Coil Replacement**.

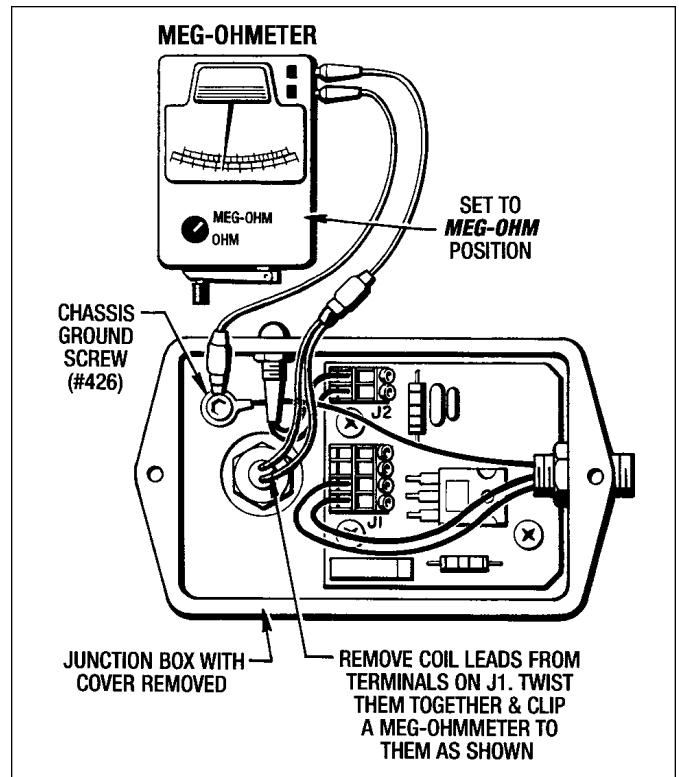

Figure 6.2 - Coil Current Leakage Testing

NOTE:

A Hi-Pot Tester can be used for this test but do not exceed 1250 VDC.

(Size MSB12 MagnaShear Motor Brake)
Pulse Width Modulation (PWM) Board With External Heat Sink

A. Coil Resistance Test

Remove the cover from the Junction Box (#405) and disconnect the (2) Coil Leads from both terminals on the Terminal Strip J1 located on the Circuit Board (#400).

Hook-Up a Meg-Ohmmeter to both coil leads as shown in Figure 6.3. Set the Meg-Ohmmeter to "Ohm" range and test Resistance at 500 VDC.

The Resistance should read as follows:

MSB12 Coil Resistance-

115 VAC	15 Ohms ± 10%
230 VAC	60 Ohms ± 10 %

A reading outside of this range would indicate that the Coil is bad and needs to be replaced. See Section 7 for Coil Replacement.

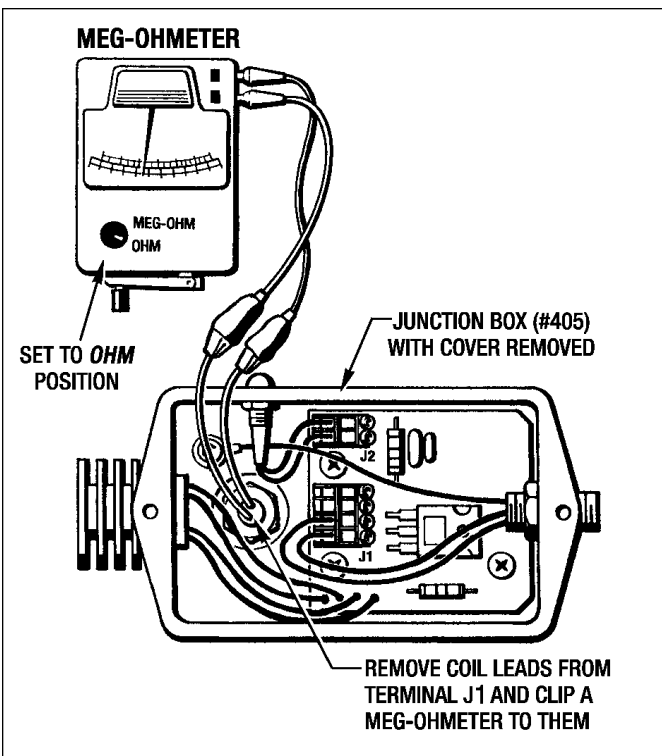

Figure 6.3 - Coil Resistance Testing

NOTE:

A Hi-Pot Tester can be used for this test but do not exceed 1250 VDC.

B. Coil Current Leakage Test

Remove the cover from the Junction Box (#405) and disconnect the (2) Coil Leads from both terminals on the Terminal Strip J1 located on the Circuit Board (#400).

Connect (1) alligator clip to both Coil Leads and the other one to Chassis Ground Screw (#426). (See Figure 6.4)

A reading of **10 Meg-Ohms or greater** indicates that the Coil is fine and does not need to be replaced. Anything much less would indicate that there is a short to ground and the Coil would need to be replaced. See Section 7 for Coil Replacement.

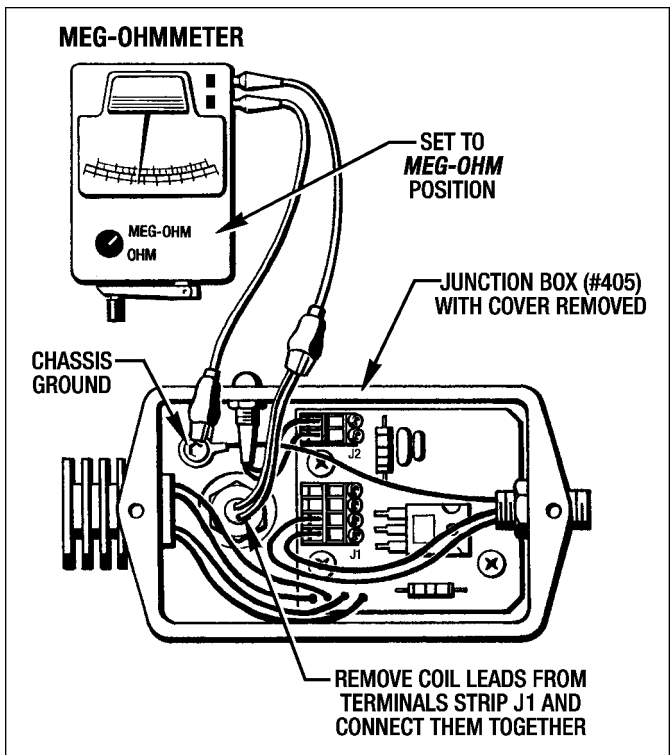

Figure 6.4 - Coil Current Leakage Testing

NOTE:

A Hi-Pot Tester can be used for this test but do not exceed 1250 VDC.

Section 7

REPAIR and REPLACEMENT

WARNING
SHUT-OFF AND LOCK-OUT ALL ELECTRICAL POWER
BEFORE ATTEMPTING TO MAKE ANY REPAIRS TO
THE BRAKE UNIT.

7-1 GENERAL INFORMATION

Unless the Motor Brake is to be completely overhauled, it should be disassembled only to the extent necessary to gain access to the worn or damaged parts.

An overhead crane and soft sling is recommended to be used to remove any heavy parts.

Tips For Handling Circuit Board:

1. Only touch the outer edges of the Circuit Board. **Do not touch any components on the Circuit Board.**
2. Make sure you always remove all static electricity from your body before handling any Circuit Boards.

Use a "Static Wrist Strap", if available, or always ground yourself first by holding on to a non-painted surface on the brake unit.

7-2 CLEANING AND INSPECTION

Clean metal parts in a suitable solvent and dry with low pressure compressed air. After cleaning inspect parts for cracks, distortion, scoring, nicks, burrs or any other damage that would affect the operation of the brake.

Pay particular attention to the Wear Sleeve (#32) on the Hub (#2) and the Oil Seal (#31) located in the Mounting Flange (#8) for the MSB9 & MSB10; for the MSB12 it is

located in the Motor Adapter Housing (#7). Check for nicks, scratches or any damage that would cause leakage.

7-3 REPAIR OR REPLACEMENT

A fine stone or #600 Grit Paper may be used to remove minor surface defects from parts if the operation or sealing action of the part is not affected. The use of coarser abrasives or other machining methods should not be attempted and damaged parts should be replaced.

Recommended Spare Parts:

1. Replace all Gaskets, O-Rings, Oil Seals and Wear Sleeves removed at disassembly.
2. Replace Brake Stack as a complete Assembly.
3. The Circuit Board (#400) is a common replacement part.

7-4 MEASURING STACK HEIGHT

The Stack Height must be measured to determine whether or not the Brake Stack needs to be replaced. If it measures under the Minimum Worn Stack Height then the Brake Stack needs to be replaced. (See Figure 7.1)

Section 8 shows exploded view drawings for each size of **MagnaShear Motor Brake**. Refer to these illustrations for all disassembly and reassembly procedures.

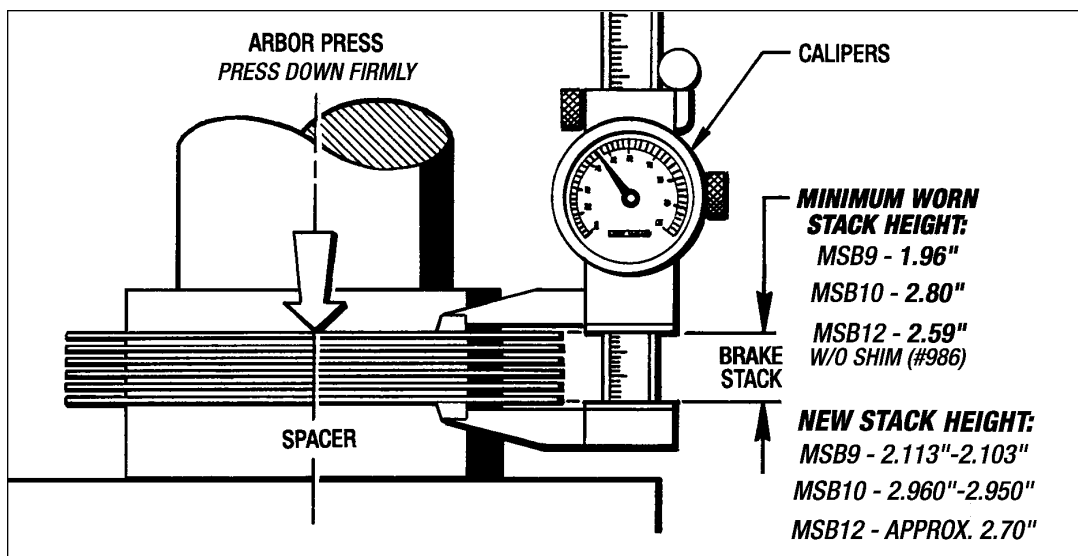

Figure 7.1 - Measuring Stack Height

Figure 8.1 - MSB9 and MSB10 Motor Brakes.

Figure 8.2 - MSB12 Motor Brake.

Figure 8.3 - Brake Coil Circuit Board and Junction Box.

Figure 8.4 - Brake Release Indicator Switch

7-5 REPLACING BRAKE STACK

A. General Instructions for all Sizes

1. First drain all the oil from the unit into a suitable container. See Section 4 LUBRICATION for location of drain plugs. Save or discard as condition warrants.
2. Disconnect the 5-Pin Brad Harrison Cable from the Conduit Box (#405). (See Figure 8.3)
3. Remove the cover from the Junction Box (#251) and disconnect the wires from the Brake Indicator Switch (#249). Loosen the Compression Nut on the Strain Relief Fitting (#419) and pull the cable out of the box. (See Figure 8.4)
4. Lift the Manual Release Lever to release the Brake.

B. Sizes MSB9 and MSB10 Motor Brakes

(See Figures 7.2 and 8.1)

1. Remove the (8) Hex Nuts (#261 and (8) Lockwashers (#127) off of the (8) Studs (#72). Pull the End Housing (#9) off the Mounting Flange (#8). Remove the Gasket (#121) and discard it

NOTE: On the MSB10 there will be another Gasket (#121) and a Spacer (#60) between the End Housing (#9) and the Mounting Flange (#8). Discard this Gasket (#121) also.

2. The Brake Stack (#12) can now be removed by unscrewing the (2) Shoulder Bolts that attaches the Drive Plates to the Mounting Flange (#8). Pull the whole Brake Stack (#12) off the Hub (#2) spline and the (4) Pins (#176). (See Figure 7.2)
3. Take the (2) Shoulder Bolts out and place the Brake Stack (#12) in an arbor press and measure the Stack Height to determine whether or not the Brake Stack (#12) needs replaced. (See Section 7-4 and Figure 7.1)
4. If the old Brake Stack (#12) needs replaced then take the new Brake Stack (#12) and remove the (4) Retaining Rings on the (4) Shoulder Bolts that holds the whole stack together. Discard these Retaining Rings they will not be needed.
5. Install the new Brake Stack (#12) and Reassembly of the Brake with the same procedure given in Section 3-5-A, Steps 11 thru 20.

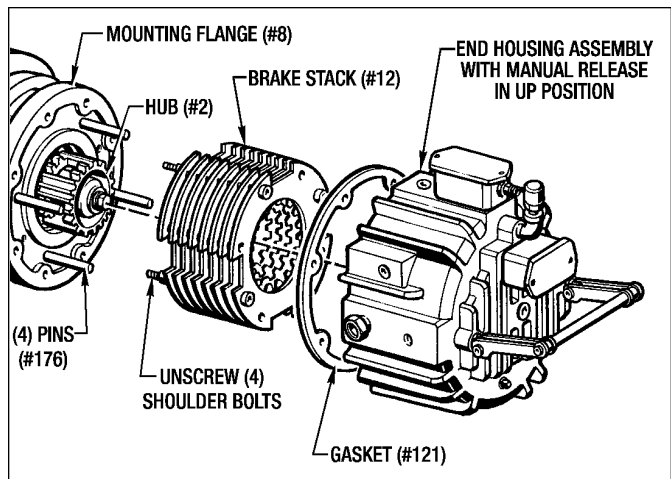

Figure 7.2 - Replacing the Brake Stack (MSB9 & MSB10)

C. Size MSB12 Motor Brake

(See Figures 7.3, 7.4 and 8.2)

1. Remove the (8) Screws (#149) and (8) Lockwashers (#127) from the Housing (#8). Pull the End Housing Assembly away from the Housing (#8). Remove the Gasket (#122) and discard it.
2. Unscrew the (4) Shoulder Bolts (#138) from the Housing (#8), but do not pull them out of the Brake Stack. Pull the complete Brake Stack including the (4) Shoulder Bolts (#138) off the (4) Pins (#176) and the Hub (#2) Spline. (See Figure 7.3)

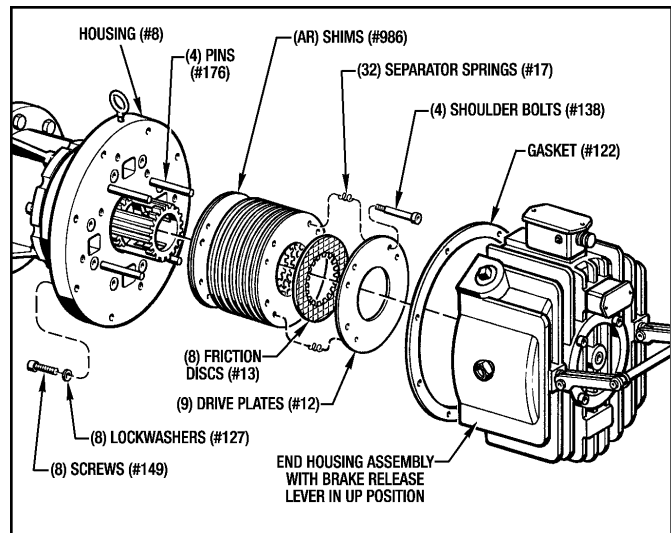

Figure 7.3 - Removing MSB12 Brake Stack

NOTE - The complete Brake Stack consists of (9) Drive Plates (#12), (8) Friction Discs (#13), Shims (#986) if required, (32) Separator Springs (#17) and (4) Shoulder Bolts (#138).

- Place all the Drive Plates (#12) and Friction Discs (#13) into an arbor press and measure the Stack Height to determine whether or not the Brake Stack needs replaced. See previous Section 7-4 and Figure 7.1.

If the Brake Stack needs replaced then the new Brake Stack, consisting of (9) Drive Plates (#12) and (8) Friction Discs (#13), needs to be measured to determine whether or not any .020" Shims (#986) are required in the stack to attain an **Air Gap of .07"-.09"**. The Air Gap is the space between the front face of the Coil (#59) and the back face of the Armature Plate (#56) with the Brass Shim (#184) attached to it. (See Figure 7.4)

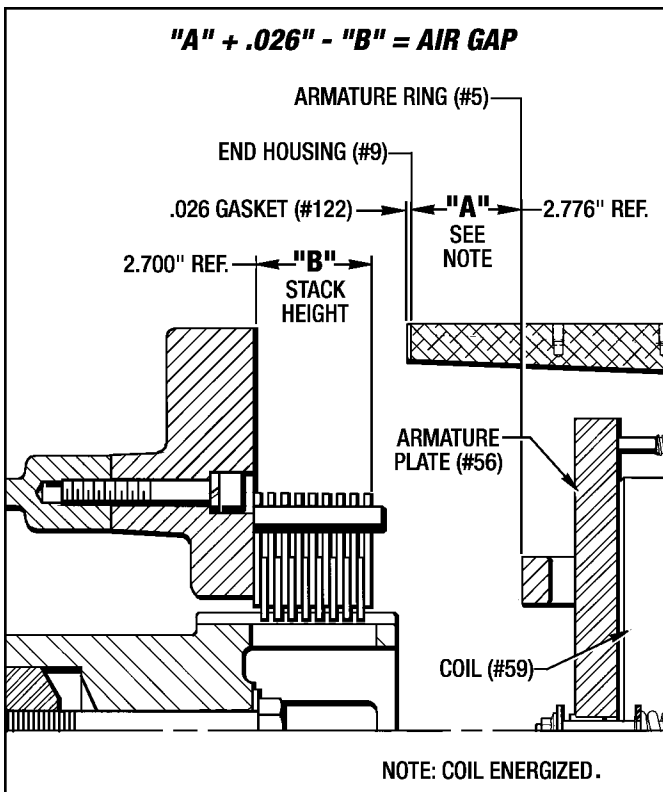

Figure 7.4 - Checking Air Gap for MSB12

- Energize the Coil.
- Measure the distance from the face of the Armature Plate (#56) to the back mounting face of the End Housing (#9) with Gasket (#122) removed. This gives **Dimension "A"**.
- Measure the new Brake Stack in an Arbor Press as shown in Figure 7.1. This gives **Dimension "B"**.
- Use the formula $"A" + .026 - "B" = \text{Air Gap}$.
- Use .020" Shim (#986) to attain **.07"-.09" Air Gap** if necessary.

- Install the new Brake Stack and Reassemble the Brake with the same procedure as described in **Section 3-5-B, Steps 11 thru 20.**

7-6 REPLACING CIRCUIT BOARD (#400)

A. Sizes MSB9 and MSB10 Motor Brake

(See Figure 7.5)

- Take the cover off the Conduit Box (#405) & remove the Brad-Harrison Cable.
- Disconnect all the wires from the (2) Terminal Strips J1 and J2 on the Circuit Board (#400).
- Disconnect the wire on the Ground Screw (#426).
- Remove the (3) Screws (#428) and (3) Nylon Washers (#431).
- Take the old Circuit Board (#400) off and replace it with a new one. See Section 7-1 for Tips on Handling Circuit Boards.
- Reattach the Circuit Board (#400) with the (3) Screws (#428) and (3) Nylon Washers (#431).
- Reconnect the wires to J1 and J2 Terminal Strips and the Ground Screw.
- Replace the cover on the Conduit Box (#405) & the Brad-Harrison Cable.

B. Size MSB12 Motor Brake

(See Figure 7.6)

- Take the cover off the Conduit Box (#405) & remove the Brad-Harrison Cable.
- Disconnect all the wires from the (2) Terminal Strips J1 and J2 on the Circuit Board (#400) and the wire on the Chassis Ground Screw (#426).
- Remove the Screw (#427) and Flat Washer (#434) which holds the Bridge Rectifier and External Heat Sink (#420) to the Conduit Box (#405). Remove the External Heat Sink (#420) and O-Ring (#437) and store for reassembly.

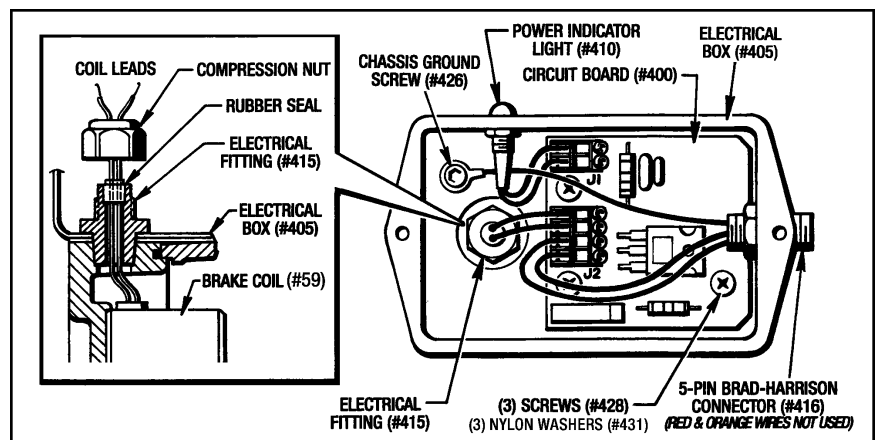

Figure 7.5 - Conduit Box with Cover Removed for Sizes MSB9 and MSB10

Brake Coil Circuit Board & Conduit Box

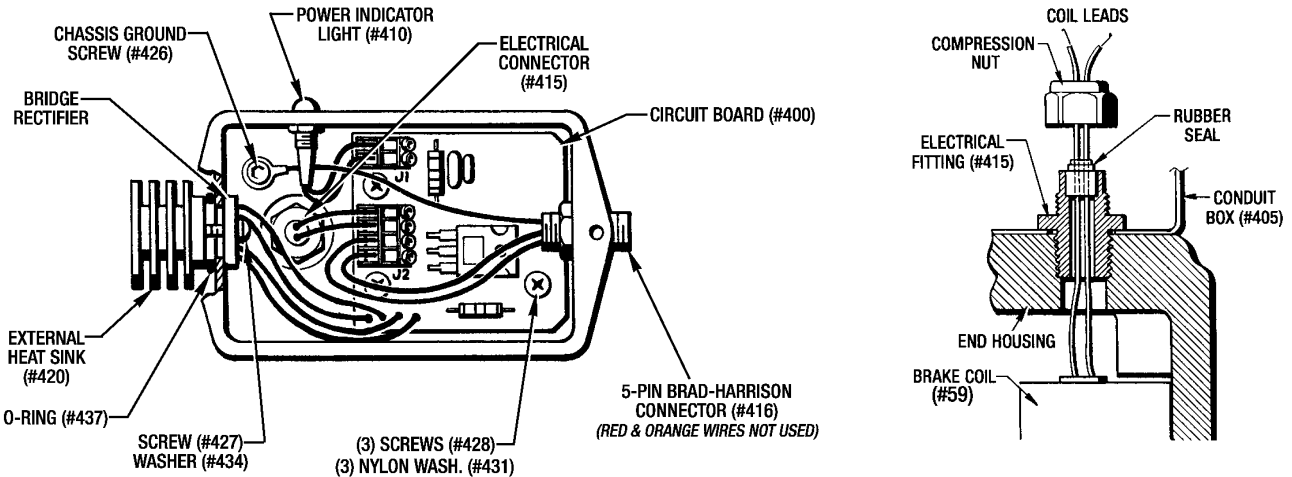

Figure 7.6 - Conduit Box with Cover Removed for Size MSB12 Motor Brake

4. Remove the (3) Screws (#428) and (3) Nylon Washers (#431).
5. Take the old Circuit Board (#400) off and replace it with a new one. **See Section 7-2 for Tips on Handling Circuit Boards.**
6. Re-attach with (3) Screws (#428) and (3) Nylon Washers (#431). Re-connect the wires to J1 and J2 Terminal Strips and the wire on the Chassis Ground Screw (#426).
7. Place the O-Ring (#437) back on the External Heat Sink (#420) and re-attach it with the Bridge Rectifier back onto the Conduit Box (#405) with Screw (#427) and Flat Washer (#434). Replace conduit box cover & Brad-Harrison Cable.

7-7 REPLACING HOLDING COIL (#59)

(See Figure 8.1 for Sizes MSB9 and MSB10)

(See Figure 8.2 for Size MSB12)

A. Disassembly

(MSB9, MSB10 and MSB12 Motor Brakes)

1. First drain all the oil from the unit into a suitable container. See **Section 4 LUBRICATION** for location of drain plugs. Save or discard oil as condition warrants.
2. Disconnect the 5-Pin Brad Harrison Cable from the Conduit Box (#405) and the wires from the Brake Indicator Switch Box (#251).
3. Lift the Manual Release Lever to release the brake.

(MSB9 and MSB10 Motor Brakes Only)

4. Remove the (8) Hex Nuts (#261 and (8) Lockwashers (#127) off of the (8) Studs (#72) Pull the End Housing (#9) off the Mounting Flange (#8).
5. Remove the Gasket (#121) and discard it.

NOTE: On the MSB10 there will be another Gasket (#121) and a Spacer (#60) between the End Housing (#9) and the Mounting Flange (#8). Discard this Gasket (#121) also.

(MSB12 Motor Brake Only)

4. Remove the (8) Screws (#149) and (8) Lockwashers (#127) from the Housing (#8). Pull the End Housing (#9) off the Housing (#8).
5. Remove the Gasket (#122) and discard it

(MSB9, MSB10 and MSB12 Motor Brakes)

6. Take the cover off of the Conduit Box (#405) and disconnect the coil leads from J1 terminal strip located on the Circuit Board (#400). Also remove the compression nut from the Electrical Fitting (#415) and pry the rubber seal out of the fitting and off of the coil leads. (See Figures 7.5 or 7.6)
7. Lower the Brake Manual Release Lever.
8. Turn the End Housing (#9) over with the Armature Plate (#56) and Thrust Plate (#5) in an Up position. **Do not rest the end housing on the Conduit Box (#251).**

(MSB9 and MSB10 Motor Brakes Only)

9. Remove the (2) Hex Nuts (#315) and (2) Lockwashers (#129) from the (2) Manual Release Shafts (#189).

(MSB12 Motor Brake Only)

9. Remove the (2) Hex Nuts (#315) and (2) Flat Washers (#274) from the (2) Manual Release Shafts (#189).

(MSB9, MSB10 and MSB12 Motor Brakes)

10. Loosen and remove the (2) Shoulder Bolts (#144) that holds the Armature Plate (#56) in place. Lift the

Armature Plate (#56) and Thrust Plate (#5) up and out of the End Housing (#9).

CAUTION: This Armature Plate (#56) is under spring pressure so loosen the (2) Shoulder Bolts evenly and very carefully.

- Note the quantity and position of Springs (#36). Make a sketch of their location to help you at reassembly or as shown in Figure 7.7.
- Remove the (4) Screws (#150) and (4) Seal Washers (#167) from the End Housing (#9). Lift the Holding Coil (#59) out of the End Housing (#9).

B. Reassembly

(MSB9 and MSB10 Motor Brakes)

- Place a new Holding Coil (#284) into the End Housing (#9), pushing the coil leads up through the Electrical Fitting (#415).
- Attach the Coil (#59) with (4) Seal Washers (#167) and (4) Screws (#150).

IMPORTANT - Torque the (4) 1/2"-13 Screws to 45 Lb. Ft.

- Set the End Housing (#9) so the Coil (#59) is facing upright. Install the Brake Springs (#36) as described below and shown in Figure 7.7.

NOTE - There are (4) Pins (#177) & (2) Pins (#179) installed in the End Housing (#9) and also (2) 3/8"-16 tapped holes for the (2) Shoulder Bolts (#144). The Pins (#177), (#179) and Shoulder Bolts (#144) are all used for the installation of the required number of Brake Springs (#36).

- Install a 3/8"-16 x 3" Lg. Set Screw in any of the shoulder bolt holes that will require a Brake Spring (#36). This will insure that the Brake Springs (#36) stays in position when the Armature Plate (#56) and Thrust Plate (#5) is placed on the springs.
- Set the Armature Plate (#56) and Thrust Plate (#5) in position on the Springs (#36). Remove any set screws. Insert the (2) Shoulder Bolts (#144) and tighten down evenly to compress the Springs (#36). **Use Blue Loctite #242 and Torque to 25 Lb. Ft.**

(MSB12 Motor Brakes)

- Place a new Holding Coil (#59) into the End Housing (#9), pushing the coil leads up through the Electrical Fitting (#415).
- Attach the Coil (#59) with (4) Seal Washers (#167) and (4) Screws (#150).

IMPORTANT - Torque the 5/8"-11 Screws to 60 Lb. Ft.

MSB9 and MSB10

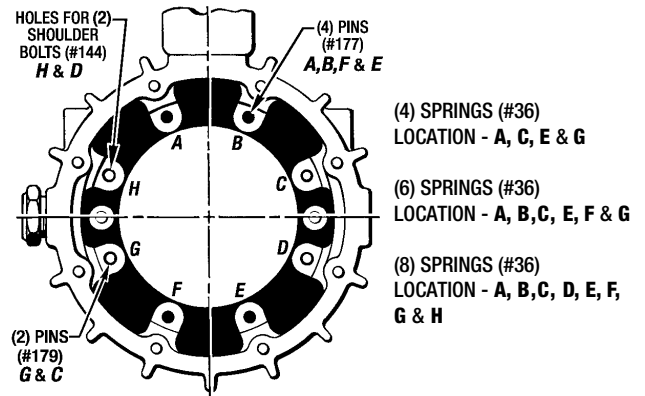

MSB12

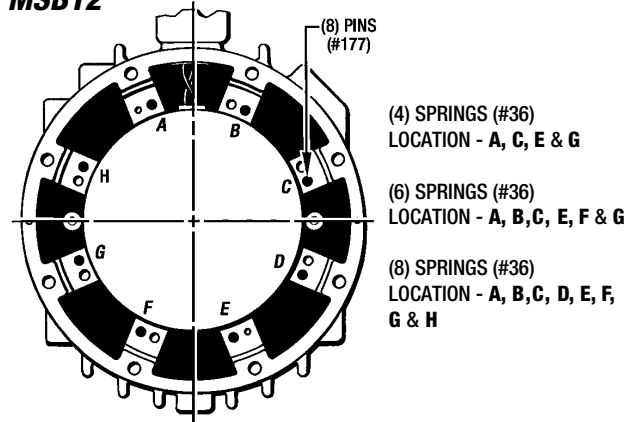

Figure 7.7 - Correct Placement of Brake Springs (#36)

- Set the End Housing (#9) so the Coil (#59) is facing upright.
- Place the correct number of Springs (#36) over the Pins (#177 as shown in Figure 7.7 .
- Set the Armature Plate (#56) and Thrust Plate (#5) in position on the Springs (#36). Insert the (4) Shoulder Bolts (#144) and tighten down evenly to compress the Springs (#36). **Use Blue Loctite #242 and torque to 25 Lb. Ft.**

(MSB9 and MSB10 Motor Brakes Only)

- Attach the (2) Lockwashers (#129) and (2) Flange Nuts (#315) to the (2) Manual Release Shafts (#189). **Torque to 25 Lb. Ft.**

(MSB12 Motor Brake Only)

- Attach the (2) Flat Washers (#274) and (2) Flange Nuts (#315) to the (2) Manual Release Shafts (#189). **Use Blue Loctite #242 and torque to 25 Lb. Ft.**

(MSB9, MSB10 and MSB12 Motor Brakes)

- Place the rubber seal on the coil leads and pull the wires through, taking up all the slack in the wires. Seat the rubber seal into the threaded part of the

Electrical Fitting (#415). Tighten down the compression nut. (See Figure 7.5 or 7.6)

- Attach the coil leads to Terminal Strip J1 on the Circuit Board (#400) and replace the Conduit Box cover. (See Figure 7.5 or 7.6).

(MSB9 and MSB10 Motor Brakes Only)

- Position a new Gasket (#121) on Mounting Flange (#8) mounting face. **Do not use any gasket sealant on this gasket.**
- Attach the End Housing Assembly with (4) Hex Nuts (#261) and (4) Lockwashers (#127). **Torque to 60 Lb. Ft.**

(MSB12 Motor Brake Only)

- Position a new Gasket (#122) on the Housing (#8) mounting face. **Do not use any gasket sealant on this gasket.**
- Attach the End Housing Assembly with (4) Screws (#148) and (4) Lockwashers (#127). **Torque to 120 Lb. Ft.**

(MSB9, MSB10 and MSB12 Motor Brakes)

- Replace Drain Plug (#64) in bottom of End Housing (#9). Fill with fresh oil to center of Sight Gauge (#46) as specified in **Section 4 - LUBRICATION.**

7-8 REPLACING WEAR SLEEVE (#32)

A. Removing Hub (#2) From The Motor Shaft

(MSB9 and MSB10 Motor Brake Only)

- Use the same procedure as described in the complete previous **Section 7-5-A** and **Steps 1 and 2 in Section 7-5-B**, to remove the End Housing Assembly and the Brake Stack.

(MSB12 Motor Brake Only)

- Use the same procedure as described in the complete previous **Section 7-5-A** and **Steps 1 and 2 in Section 7-5-C**, to remove the End Housing Assembly and the Brake Stack.

(MSB9, MSB10 and MSB12 Motor Brakes)

- Hold the Hub (#2) with the Hub Holding Tool #601-20-024 and remove the Collet Locking Bolt (#94) and the Copper Washer (#81) from the Hub (#2). Discard the Copper Washer (#81).

(MSB9 Motor Brake Only)

- Insert a 5/8"-11 Set Screw then a 3/4"-10 x 4" Lg. Hex Hd. Jack Screw into the Hub (#2) as shown in Figure 7.8. While holding the Hub (#2) with the Hub Holding Tool tighten the Jack Screw to push the Hub (#2) off the Collet (#110).

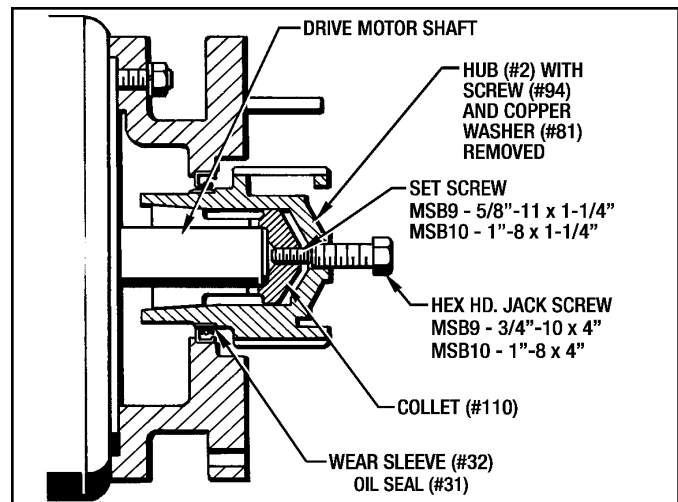

Figure 7.8 - Removing Hub (#2) for MSB9 and MSB10

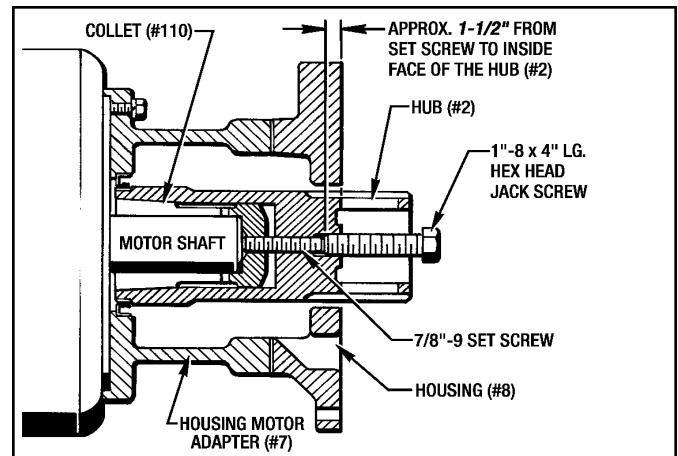

Figure 7.9 - Removing Hub (#2) for MSB12

(MSB10 Motor Brake Only)

- Insert a 3/4"-10 Set Screw then a 1"-8 x 4" Lg. Hex Hd. Jack Screw into the Hub (#2) as shown in Figure 7.8. While holding the Hub (#2) with the Hub Holding Tool tighten the Jack Screw to push the Hub (#2) off the Collet (#110).

(MSB12 Motor Brake Only)

- Install a 7/8"-9 Set Screw into the Collet (#110). Determine the length of this Set Screw so there is approx. 1-1/2" of exposed thread left in the Hub. Then install a 1"-8 x 4" Lg. Hex Hd. Jack Screw into the Hub (#2). While holding the Hub (#2) with the Hub Holding Tool, tighten the Jack Screw to force the Hub (#2) off the Collet (#110) as shown in Figure 7.9).

B. Removing Wear Sleeve (#32)

(MSB9, MSB10 and MSB12 Motor Brakes)

- Place the Hub (#2) into a V-Block. Using a chisel the same width as the Wear sleeve (#32), make about 5

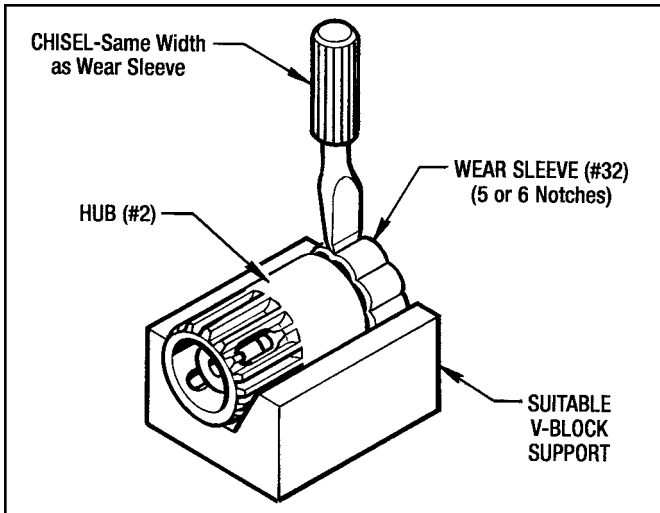

Figure 7.10 - Removing Wear Sleeve (#32)

or 6 notches in the Wear Sleeve (#32), as shown in Figure 7.10. It can now be removed by hand.

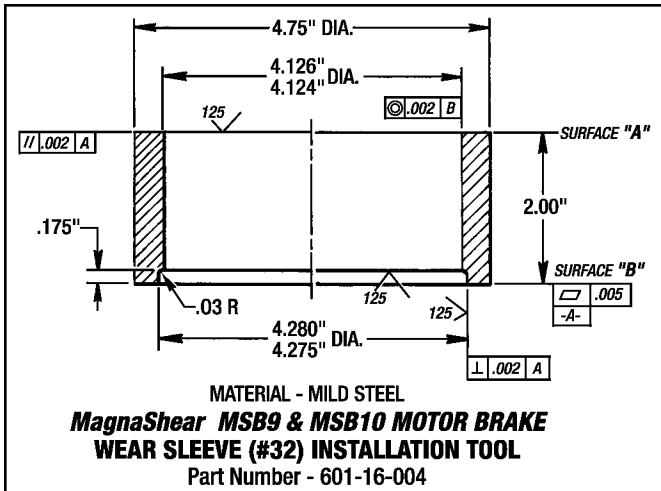

Figure 7.11 - Wear Sleeve Installation Tool

C. Installing Wear Sleeve (#32)

(Sizes MSB9 and MSB10 Only)

A Special Wear Sleeve Installation Tool must be used to install the Wear Sleeve (#32) onto the Hub (#2).

Dimensions and Specifications are given in the following Figure 7.11 if you prefer to make your own. It can be ordered from Force Control with the following Part Number 601-16-004.

1. Clean the surface of the Hub (#2) with **Loctite Primer-T** and then apply **Red Loctite #271** to the hub surface.
2. Place the Hub (#2) into an Arbor Press and with **Surface "A"** of the Installation Tool press the Wear Sleeve (#32) on as far as it will go. (See Step #1 in Figure 7.12)

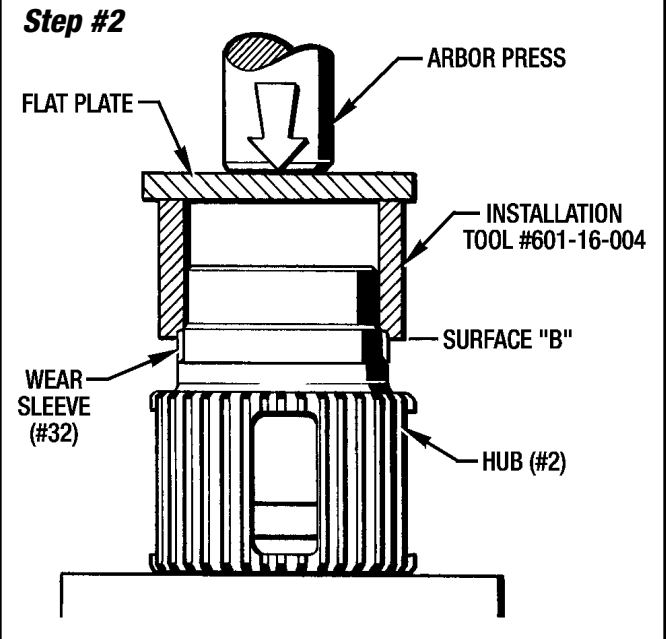
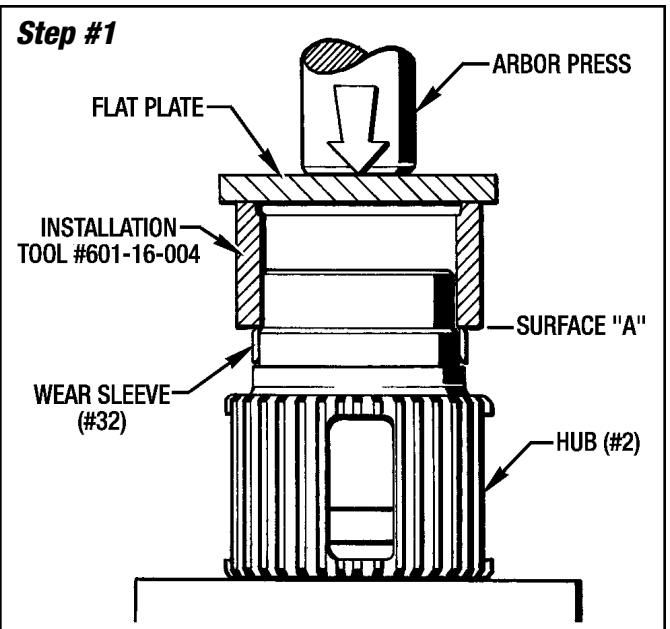

Figure 7.12 - Installing Wear Sleeve (#32) on Sizes MSB9 and MSB10

Turn the Installation Tool over and with **Surface "B"** continue pressing the Wear Sleeve (#32) until it bottoms out on the shoulder. (See Step #2 in Figure 7.11)

Clean off any excess Loctite.

(Size MSB12 Only)

Just a flat plate is required to install the Wear Sleeve (#32) on to the Hub (#2)

1. Clean the surface of the Hub (#2) with **Loctite Primer-T** and then apply **Red Loctite #271** to the hub surface.

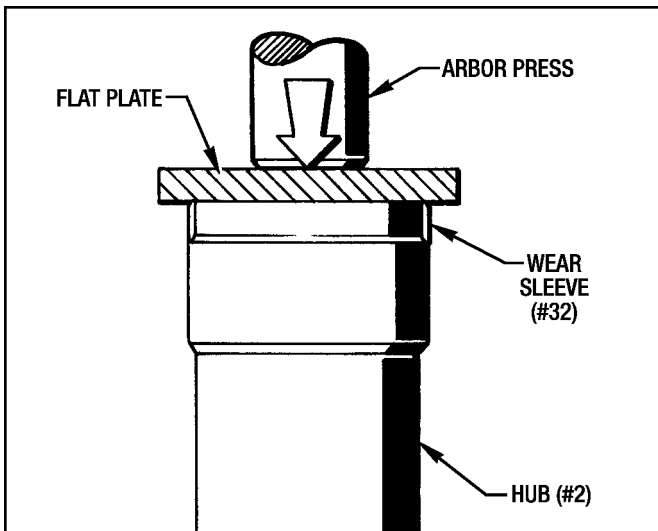

Figure 7.13 - Installing Wear Sleeve (#32) on MSB12

2. Place the Hub (#2) into an Arbor Press and with a flat plate as shown in Figure 7.13 on the next page press the Wear Sleeve (#32) on to the Hub (#2) as far as it will go. Clean off any excess Loctite

7-9 REPLACING OIL SEAL (#31)

(MSB9 and MSB10 Only)

1. Remove (4) Hex Nuts (#392) and (4) Lockwashers (#168). Pull the Mounting Flange (#8) off of the motor face.
2. Press the Oil Seal (#31) out of the Mounting Flange (#8) with an arbor press.
3. Clean out the oil seal bore in the Mounting Flange (#8) and lightly coat the bore with Permatex #30 Sealant.

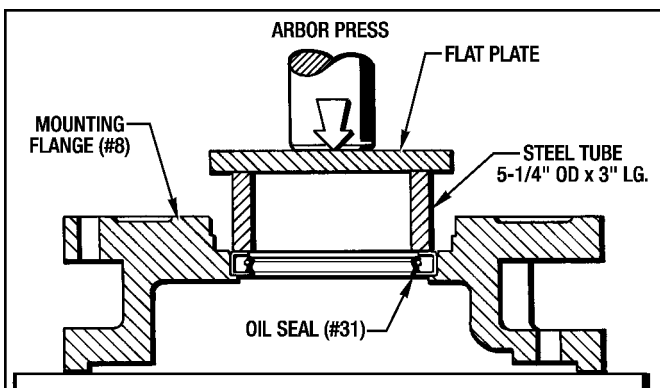

Figure 7.14 - Installing Oil Seal for MSB9 and MSB10

CAUTION - Be very careful not to get any of the sealant on the rubber parts of the Oil Seal (#31).

4. Press the new Oil Seal (#31) into the bore with an arbor press as shown in Figure 7.14.
5. Clean off any excess sealant.

(MSB12 Only)

1. Remove the (8) Screws (#151) and (4) Lockwashers (#129). Pull the Housing (#8) and the Gasket (#121) off of the Motor Adapter Housing (#7). Discard the Gasket (#121).
2. Remove (8) Screws (#166) and (8) Lockwashers (#168). Pull the Motor Adapter Housing (#7) away from the motor face.
3. Press the Oil Seal (#31) out of the Motor Adapter Housing (#7).
4. Clean out the oil seal bore in the Motor Adapter Housing (#7) and lightly coat the bore with Permatex #30 Sealant.

CAUTION - Be very careful not to get any of the sealant on the rubber parts of the Oil Seal (#31).

5. Press the new Oil Seal (#31) into the bore with an arbor press as shown in Figure 7.15.

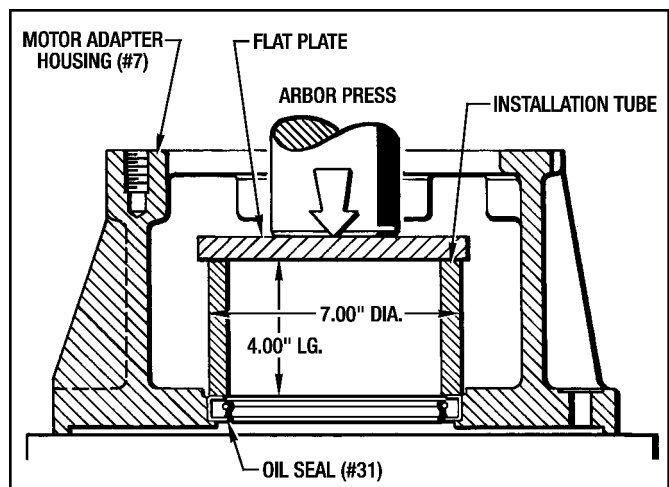

Figure 7.15 - Installing Oil Seal for MSB12

6. Clean off any excess sealant.

7-10 REPLACING BRAKE INDICATOR SWITCH (#249)

(See Figure 8.4)

Make sure the electrical power is shut off and locked out to avoid the possibility of any personal injury.

1. Remove the cover from the Switch Enclosure (#251).
2. Disconnect the leads from the switch terminals.
3. Take out the (2) Screws (#328). Pull the Bracket (#332) and the Switch (#249) out of the Switch Enclosure (#251).

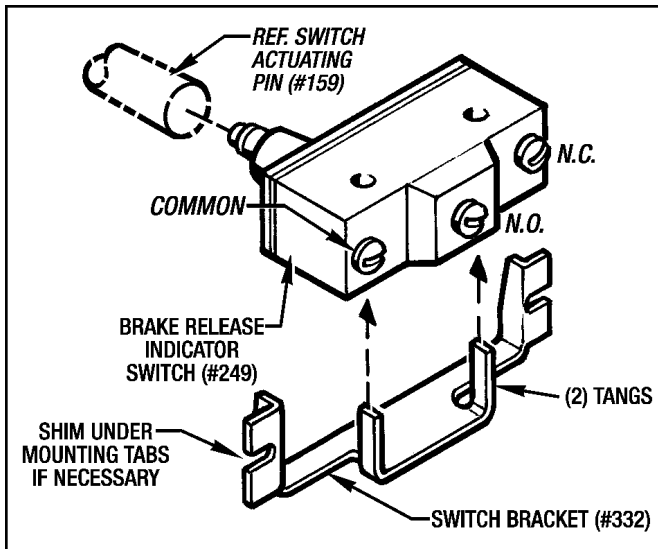

Figure 7.16 - Brake Release Indicator Switch

4. Pry the Switch (#249) up and off the (2) tangs on the Switch Bracket (#332) as shown in Figure 7.16.
5. Push the (2) tangs up and into the new Switch (#249).
6. Attach the Bracket (#332) to the (2) PEM Standoffs with (2) Screws (#328). **Use Blue Loctite #242.** Make sure the switch plunger is aligned with the Switch Actuating Pin (#159).
7. Reconnect the electrical leads to the switch terminals.
8. Manually activate the brake to make sure the Switch (#249) operates properly. Shim under the mounting tabs of the Bracket (#332) if necessary to position the Switch (#249) properly.
9. Replace the cover to the Switch Enclosure (#251)

7-11 BRAKE REASSEMBLY PROCEDURE

(MSB9 and MSB10 Only)

1. Attach the Mounting Flange (#8) to the motor face with (4) Hex Nuts (#392) and (4) Lockwashers (#168). **Torque to 120 Lb. Ft.**
2. Install and align the Hub (#2) and Collet (#110) on the motor shaft with the same procedure given in **Section 3 - INSTALLATION, 3-4-A Mounting the MSB9 and MSB10 to the Drive Motor, Steps 7 thru 10.**

3. Install the Brake Stack (#12) with the same procedure given in **Section 3 - INSTALLATION, 3-4-A Mounting the MSB9 and MSB10 to the Drive Motor, Steps 11 thru 19.**
4. Install the End Housing (#9) with the same procedure given in **Section 3 - INSTALLATION, 3-4-A Mounting the MSB9 and MSB10 to the Drive Motor, Steps 201 thru 22.**

(Make sure the Manual Release Lever is in the Up Position.)

(MSB12 Only)

1. Attach the Motor Adapter Housing (#7) to the motor face with (8) Screws (#166) and (4) Lockwashers (#158). **Torque to 120 Lb. Ft.**
2. Place a new Gasket (121) onto the Motor Adapter Housing (#7). **Do not use any gasket sealant on this gasket**
3. Attach this Housing (#8) and Gasket (#121) to the Motor Adapter Housing (#7) with (8) Screws (#151) and (8) Lockwashers (#129). **Torque to 120 Lb. Ft.**
4. Install and align the Hub (#2) and Collet (#110) on the motor shaft with the same procedure given in **Section 3 - INSTALLATION, 3-4-B Mounting the MSB12 to the Drive Motor, Steps 6 thru 9.**
5. Install the Brake Stack with the same procedure given in **Section 3 - INSTALLATION, 3-4-B Mounting the MSB12 to the Drive Motor, Steps 10 thru 19.**
6. Install the End Housing (#9) with the same procedure given in **Section 3 - INSTALLATION, 3-4-B Mounting the MSB12 to the Drive Motor, Steps 20 thru 22.**

(Make sure the Manual Release Lever is in the Up Position.)

(All Sizes)

Make sure Air Breather, Sight Gauge and all pipe plugs are installed. Fill with fresh oil to level of the Sight Gauge. **See Section 4 - LUBRICATION.**

Section 8

ILLUSTRATED PARTS LIST

8-1 GENERAL INFORMATION

This section illustrates, lists and describes all parts for **Sizes MSB9, MSB10 and MSB12 MagnaShear Motor Brakes**. Parts are identified on the exploded views with Part Reference Numbers. These Numbers correspond to the Part Reference Number given in the Parts Lists. The Part Name and Quantity Used is also given in the Parts List. This Part Reference Number, Part Name and Quantity should be used when ordering Replacement Parts.

8-2 DRIVE MOTORS

The Drive Motors used with these **MagnaShear Motor Brakes** are standard motors and may be repaired or replaced by any qualified Motor Re-build Facility or Supplier.

8-3 FACTORY REBUILD SERVICE

Reconditioning Service is offered by Force Control Industries, Inc. at the factory. A complete factory rebuild will be 50% the cost of a new unit if the housings are reusable. If Housings need to be replaced, there will be an additional cost.

Contact Force Control Industries, Inc. for authorization and shipping instruction before returning a drive unit for this service. Force Control cannot be responsible for units returned to the factory without prior notice and authorization.

Care must be given to the packing of returned drives. Always protect mounting feet by attaching to a skid. Shipment-damaged drives always delays repairs. It is

usually impossible to recover damage costs from the carrier. When possible, describe the problem experienced on your shipping papers.

Return to: **Force Control Industries, Inc.**
3660 Dixie Highway
Fairfield, Ohio 45014

Phone: (513) 868-0900

Fax: (513) 868-2105

E-Mail: info@forcecontrol.com

Web: www.forcecontrol.com



8-4 ORDERING REPLACEMENT PARTS

When ordering replacement parts, please specify all of the following information:

1. Brake Model Number (On the Name Plate.)
2. Brake Serial Number (On the Name Plate.)
3. Part Reference Number (From the parts list or exploded view drawing.)
4. Part Name (From the parts list.)
5. Quantity (From the parts list.)
6. Complete Shipping Information.

Failure to include information for items 1 through 6 will only delay your parts order. Unless another method is specified for item 6, parts weighing less than 150 Lbs. will be shipped United Parcel Service. Parts weighing more than 150 Lbs. will be shipped Motor Freight. Air freight and other transportation services are available but only if specified on your order.

REPAIR PARTS LIST
BRAKE RELEASE INDICATOR SWITCH
(Figure 8.4)

Ref. No.	Part Name	Qty.	Ref. No.	Part Name	Qty.
106	Poly-Pak Seal	1	332	Switch Bracket.....	1
113	Lock Screw	1	*402	Gasket	1
117	Drill Bushing	1	417	Nut-Nylon Fitting	1
159	Switch Actuating Pin	1	418	Sealing Ring	1
203	Spring	1	419	Nylon Strain Relief Fitting	1
204	Retaining Ring	1	429	Button Hd. Screw, 1/4"-20 x 1/2" Lg.....	3
249	Electrical Switch	1	432	1/4" Lockwasher	3
251	Switch Enclosure	1	435	PEM Standoff.....	2
328	Pan Head Screw	2			

NOTES:

* - Indicates parts in Overhaul Kit.

BRAKE RELEASE INDICATOR SWITCH

Figure 8.4 - Brake Release Indicator Switch

FORCE CONTROL INDUSTRIES, INC.
Worldwide Leader in Oil Shear Technology

*Providing Today's Industries
with Oil Shear Clutch & Brake Drives
and Electronic Drive Systems That Delivers:
Flexibility • Efficiency
Endurance • Performance
Dependability*

“Built to Last - Guaranteed to Perform”



FORCE CONTROL INDUSTRIES, INC.

MAIN OFFICE

P.O. Box 18366
Fairfield, Ohio 45018

3660 Dixie Highway
Fairfield, Ohio 45014

Tel: (513) 868-0900
Fax: (513) 868-2105



E-Mail: info@forcecontrol.com
Web: www.forcecontrol.com