

# Section 11 Electronic Position Controls & Encoders

## CLPC™ Closed Loop Position Controls

The **CLPC Closed Loop Position Control** is used to improve positioning accuracy on *Posidyne* Clutch/Brakes and *Posistop* Motor Brakes beyond what can be achieved with just a limit switch, or a PLC control system. The **CLPC** is a closed loop positioning control, which looks at the stopping position and continually makes adjustments if any “Stopped Position” errors begin to occur. This is particularly important during a cold start to hot run, and if changes that occur on the line such as changes in load, speed or temperature.

### FEATURES:

- **Closed Loop, error compensating** - Corrects the stopping position on each index for precise accuracy.
- **Self compensating** - Control compensates for changes in speed, dynamic load, air pressure, friction in bearings, slides, etc.
- **Simple, straight forward** - Minimal programming, no complex velocity profiles to develop.
- **In Position** - Output indicates drive has reached position.
- **Optional MIP/PLS** - Multiple Indexing Parameter groups. Select between 16 different index distances that are user programmed. Programmable Limit Switch is capable of 4 Programmable Outputs based on position.
- **Complete Package** - No need for external power supplies or accessories.
- **Watchdog timer** - Control will stop index if not made within the set time frame adjustable from 100 milliseconds to 1 minute.
- **Stall detection** - Control will stop the drive when it senses the system comes to an unexpected stop, preventing damage to the clutch, or other components in the system.
- **Easy installation and operation** - Simple menu to set-up, with on the fly electronic fine tuning of the start/stop position.
- **Ultra-Quick** - Interrupt driven microcontroller, no scan time problems.

Typical System Diagram (CLPC-LC, Posidyne Clutch/Brake with Optical Encoder)

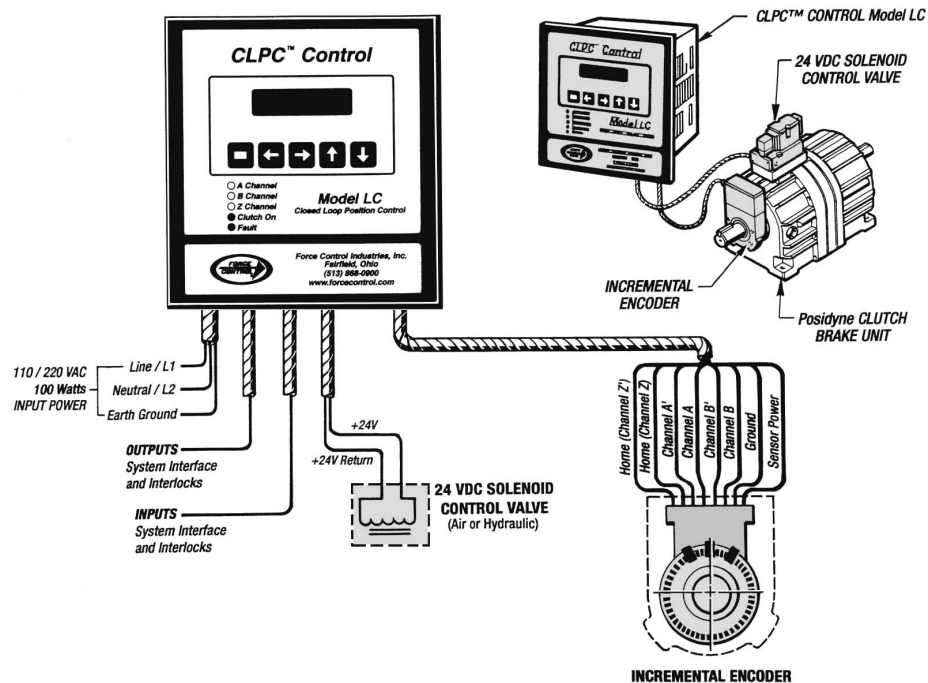



A. CLPC Control Model LC

## CLPC™ Control Model LC

### The CLPC Control Model LC

The basic **CLPC Control Model LC** is designed to operate a standard *Posidyne* Clutch/Brake in an indexing application. The **CLPC-LC** is programmed for the desired index distance (encoder counts). The **CLPC-LC** will energize the clutch valve until the trigger point, de-energize the valve and stop in position. The trigger point is self compensating to actuate the brake at the proper time to consistently stop in position and will float as conditions change. The **CLPC Control Model LC** is a single direction single clutch drive control.

The CLPC Control Model LC has numerous features such as:

- **Universal Supply Input** - 85-264 VAC, 47-63 Hz.
- **Interface** - All functions adjustable with a simple menu through a display panel.
- **Program Lockout** - via external cold contact.
- **Eleven Internally Tested Functions** - Error Codes with descriptions displayed to identify Faults.
- **Compact Design** - Door Mount or Panel Mount.
- **Always Ready** - No calibration required.
- **Stall Detection** - Detects a jam (no rotation of the encoder) before reaching the desired stop position and disengages the clutch.
- **Watch Dog Timer** - Adjustable (100 milliseconds to 1 minute) timer which will disengage the clutch if timed out before reaching the desired stop position. Used to protect against jams which may stop or slow down the drive.
- **Encoder Resolution Settings** - X1, X2 and X4.
- **Manual Adjustment** - Allows a positive or negative adjustment from the home sensor position. Used to align the machine position with the home sensor
- **Emergency/Fault Stop** - Abort Input allows the control to react to an external request to stop the index or prevent any further indexes from occurring.
- **In Position Output** - An output to indicate when the drive has reached position. A plus or minus count can be set as an allowable in position window.
- **Optional (MIP/PLS)** - Multiple Indexing Parameter groups - Capable of storing up to 16 different groups (Index Distances). Programmable Limit Switch - Capable of 4 Programmable Outputs based on position.

### Electrical Enclosure Dimensions (Inches)

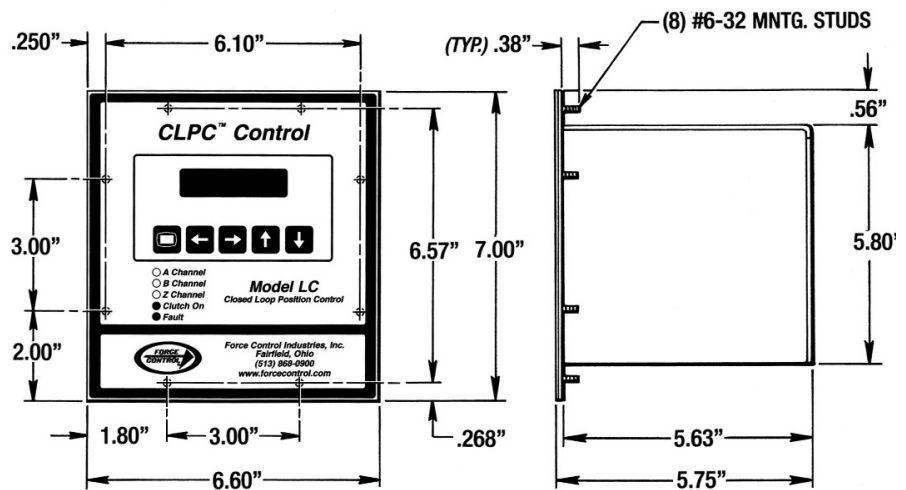

Dimensions are subject to change without notice. Certified Installation Drawings are available upon request.

### Typical Applications

Assembly Line Part Conveyor (CLPC-LC Control)

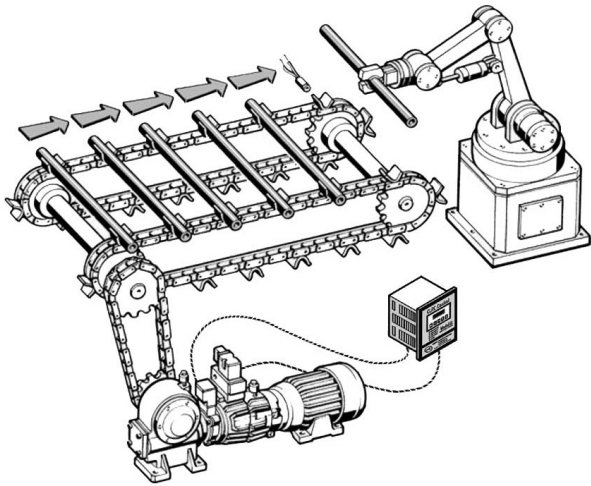

Part Cut-Off - CLPC-LC (CTL) Cut-To-Length Control

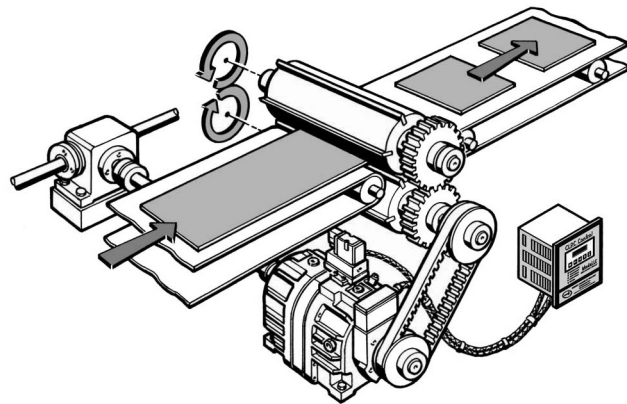

Case Packer (CLPC-LC Control)

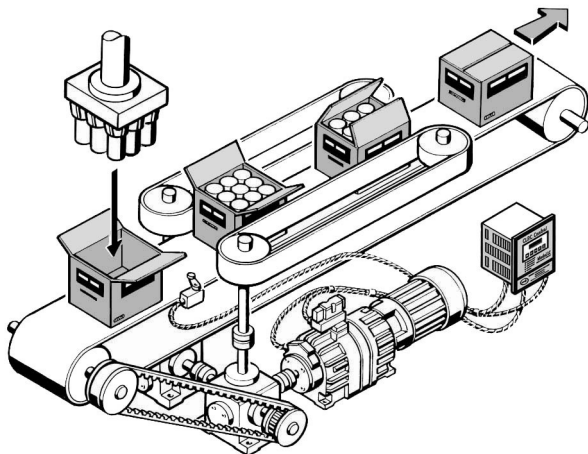

Ferris Wheel Turn Over (CLPC-LC Control)

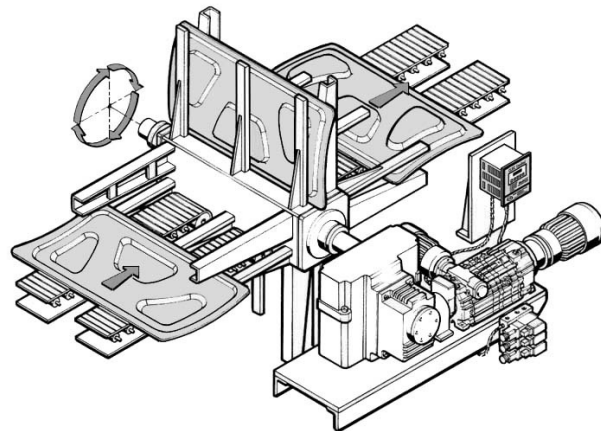

Press Feeder - CLPC-LC (FTL) Feed-To-Length

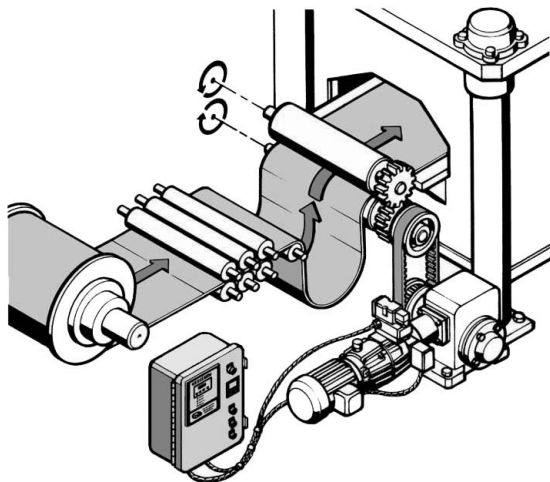

Wire Feed Application (CLPC-LC Control)

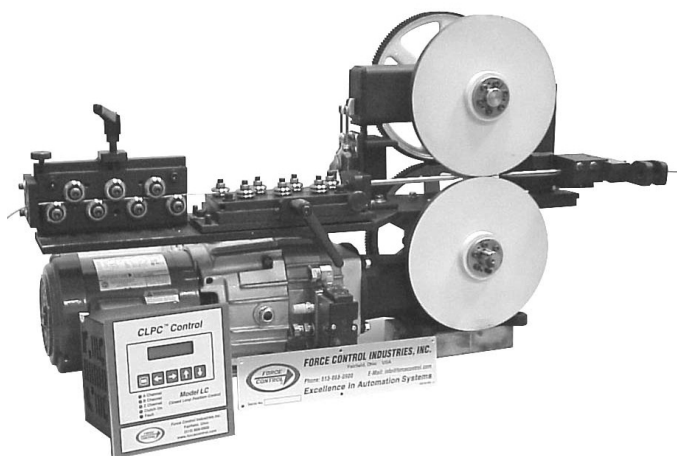

## General Specifications

## CLPC™ Control Model LC

### Electrical

<b>Input Power</b>	85-264 VAC, 47-63 Hz., Single phase, 100 watts max., Fused @ 4 amps.
<b>Encoder Input</b>	Six Signals: A, A', B, B', Z and Z'; 7.2 kHz max.; 0-3 VDC (Low), 2-12 VDC (High)
<b>Auxiliary Supply</b>	12 VDC, 1 amp, Current limited, Short circuit protected. Used for Encoder and Home Switch.
<b>Solid State Inputs</b>	Three: 120 VAC and 24 VDC standard, Fused @ 1/16 amps, - Start Cycle, Fault Reset and Abort Cycle.
<b>Program Interlock Input</b>	External cold contact switch required
<b>Solid State Outputs</b>	Two: 115 VAC standard (7 to 60 VDC available), Fused @ 3 amps, N.O. - Fault and In Position,
<b>Clutch/Brake Output</b>	One: 24 VDC, 1 amp max., Fused @ 3 amps.
<b>Displays</b>	16 characters by 2 lines, .22" character height, Backlit
<b>LED Status Indicators</b>	Five: Channel A, Channel B, Z Channel, Clutch On, Fault.
<b>Diagnostics</b>	Eleven: Internally tested functions. Error codes and description displayed to identify faults.

### Mechanical

<b>Enclosure</b>	Aluminum/Stainless, Black anodized, NEMA 1, IP20 Enclosure. NEMA 4, IP66 when door mounted with gasket
<b>Weight</b>	3.5 Lbs.
<b>Dimensions</b>	6" x 6" Face x 5-3/4" Deep

### Environmental

<b>Operating Temp.</b>	32° - 140° F (0 - 60° C)
<b>Storage Temp.</b>	0° - 186° F (-18° - 85° C)
<b>Ambient Humidity</b>	90% non-condensing max.
<b>Vibration</b>	2.5 g's, 30 to 200 Hz.

### Programmability

<b>Interface:</b>	All functions adjustable through display panel push buttons. Some of these Functions include:
<b>Index Count</b>	Up to 65,535 pulses.
<b>Manual Adjust</b>	± 1/4 of maximum count.
<b>Encoder Input Control</b>	x1, x2 and x4 operation.
<b>Watch Dog Timer</b>	Off, 100 ms to 1 min. in 16 increments.
<b>Push Buttons</b>	Five: Program, Menu Back, Menu Forward (Fault Reset), Increment and Decrement.
<b>Optional (MIP/PLS)</b>	Multiple Indexing Parameter Groups - Capable of storing up to 16 different groups. Programmable Limit Switch - Capable of 4 Programmable Outputs based on position.

## How to order your CLPC™ Model LC Control

### Ordering System Chart

Example: *CLPC-14-B-S-D-A-A-N-N-8*



**Model (a, b)**

**1** **4** = Model LC

**Overlay (1)**

**B** = Standard (Force Blue)  
**[ ]** = Other (*Consult Factory*)

**Chassis Options (2)**

**S** = Door Mount  
**P** = Panel Mounted

**In Position Output (3)**

**N** = None  
**A** = 115 VAC  
**D** = 24 VDC  
**1** = 240 VAC

**Fault Output (4)**

**N** = None  
**A** = 115 VAC  
**D** = 24 VDC  
**1** = 240 VAC

**Input Power (5)**

**A** = 115 VAC to 230 VAC

**Unused (6)**

**N** = None

**Unused (7)**

**N** = None

**Options (8)**

**N** = None  
**1** = 115 VAC (PLS)  
**2** = 24 VDC (PLS)  
**3** = 115 VAC (MIP)  
**4** = 24 VDC (MIP)  
**5** = 115 VAC (PLS) + 115 VAC (MIP)  
**6** = 24 VDC (PLS) + 115 VAC (MIP)  
**7** = 115 VAC (PLS) + 24 VDC (MIP)  
**8** = 24 VDC (PLS) + 115 VAC (MIP)

**PLS** = Programmable Limit Switch  
**MIP** = Multiple Index Parameters

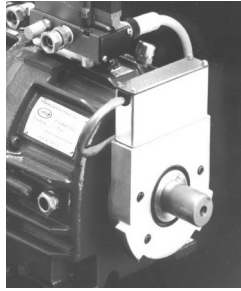

## Incremental Optical Encoders

The Optical Encoder provides the pulse counting system for the CLPC Closed Loop Position Control using a disc with precision holes and photo interrupters placed in the correct position. By sending a pulse when the interrupter sees the edge of a hole, an accurate count is made. Using two interrupters improves the resolution and the direction of rotation is also known. A third interrupter is used to establish a home position. The home position is used as a starting point for the count, which eliminates any possibility of any accumulated error.

### FEATURES:

- **Low inertia pulse disc** - Reduces cyclic load.
- **Precision counting** - Eliminates errors due to metallic build up in the encoder housing.
- **Differential line driver** - Reduces any chance of error to the control due to long encoder line runs, or electrical noise from other operating machinery.
- **Heavy-duty circuit board** - Made for use in dirty industrial applications.
- **Sturdy aluminum housing** - Made to fit on the various sizes of *Posidyne* clutch/brakes provides sealed protection for the encoder disc and electronic circuits.
- **4 pair shielded cable with connector** - Furnished with the encoder.

The (2) basic types of Optical Encoders are:

1. **Posidyne Mounted Encoders** are directly mounted to the output housing and output shaft of the *Posidyne* Clutch/Brake Unit. They are available for all sizes of Single Clutch and Dual Clutch *Posidyne* Units. (See each specific section for dimensions and see this section for all specifications, additional information and ordering information.)
2. **Double C-Face Encoders** could also be mounted on the output end of the *Posidyne* Unit or Motor and then be C-Face mounted to a gear reducer or mounted on the back end of a Brake Motor between the motor and the brake. These C-Face Encoders come with a 4-1/2" AK register. They can accept a 5/8" Dia. and 7/8" Dia. Shaft. (See this section for additional information and ordering information.)

### Posidyne Mounted Encoder

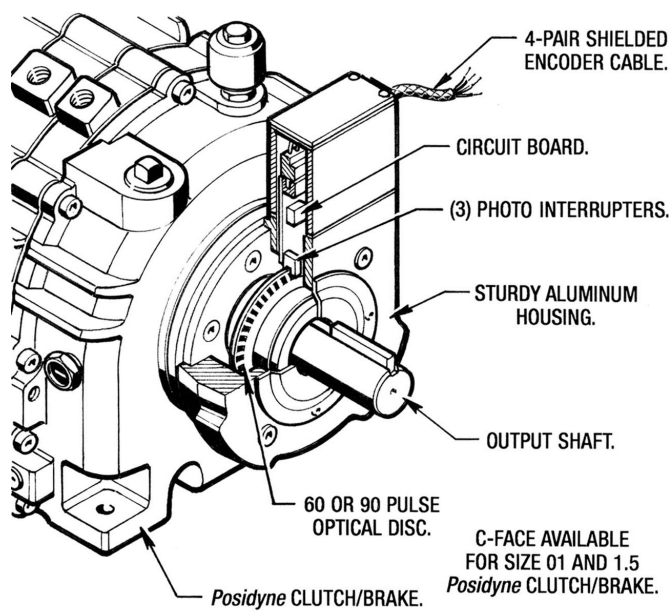

### Double C-Face Encoder

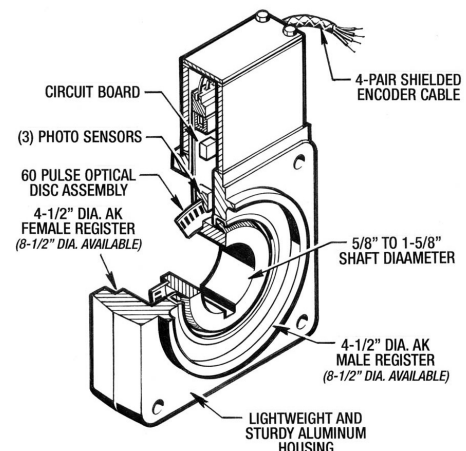

This type of Encoder can be used in any applications where NEMA standard C-Face Motors and Gear Reducers are used.

The above application shows a double C-Face Encoder sandwiched in between a 1.5 *Posidyne* Clutch/Brake and a Eurodrive Reducer which is operating a swing plate to divert shingle direction.

#### Typical Application

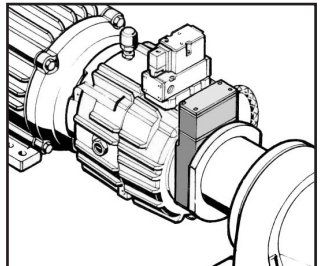

## Optical Encoder Specifications...

Electrical Specifications (All Optical Encoders)	
Input	
<b>Voltage</b>	5 to 15 VDC.
<b>Current</b>	100 mA max. (with No Line Loading).
<b>Ripple</b>	2% peak to peak @ 5 VDC input.
<b>Regulation</b>	± 5% for 5 VDC power supply.
Output	
<b>Type</b>	Quadrature (A & B) with zero ref. (Z) plus 1 spare channel. All with differential line driven square wave outputs.
<b>PPR</b>	<i>Posidyne</i> C-Face Encoder - 60 count for sizes 1.5 to 10 <i>Posidyne</i> 90 count for sizes 11, 14 and 20 <i>Posidyne</i>
<b>Current</b>	Sinking, 250 mA open drain (Collector). Sourcing, 250 mA open source (Emitter) No pull ups or downs.
<b>Circuit</b>	TC1 428 Dual High Speed Mosfet Driver. Latchup Protection: Will withstand 500 mA reverse output current. ESD Protection to ±2000 volts. High Output Peak Voltage: 1.2A peak. High Capacitance Load: 1000pF in 38nS. Output voltage swing to within 25mV to ground or the control voltage. Low Output Impedance: 8 ohms.
<b>Freq. Response</b>	250K CPS.
<b>Symmetry</b>	180 electrical degrees ±18°.
<b>Quad. Phasing</b>	90 electrical degrees ± 36°.
<b>Rise Time</b>	Less than 1 microsecond.
<b>Accuracy</b>	Within ± 0.1° from one pulse to next pulse, or 60 arc min.
<b>Elect. Conn.</b>	10 pin Phoenix 1827787

Environmental Specifications (All Optical Encoders)	
<b>Operating Temp.</b>	0° to 70° C.
<b>Storage Temp.</b>	-25° to 85° C.
<b>Humidity</b>	95% RH Non-Condensing.
<b>Vibration</b>	10 G's @ 50 to 500 CPS.
<b>Shock</b>	50 G's @ 10 mS duration.

Mechanical Specifications (Posidyne Mounted)
<b>Max. Operating Speed</b> = 3600 rpm
<b>Inertia</b> = .00916 Lb. Ft. <sup>2</sup>
<b>NEMA Rating</b> = 12

Mechanical Specifications (Double C-Face Mounted)
<b>Max. Operating Speed</b> = 3600 rpm
<b>Inertia</b> = .00916 Lb. Ft. <sup>2</sup>
<b>NEMA Rating</b> = 12
<b>Register</b> = 4-1/2"AK or 8-1/2" AK

## How to order your Encoder...

**Ordering System Number** Example: E-PM-T-60-E

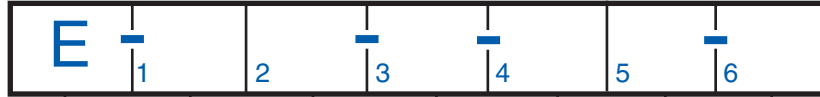





ENCODER

Encoder Type (1,2)

- P** **M** = Posidyne Mounted (Std.)
- C** **4** = Double C-Face, 4-1/2" AK\*

\* C-Face Encoders can be Posidyne Mntd.

Mounting Position (3)

- T** **R** **B** **L** **N**
-     **N** Does Not Apply
- Top Right Bottom Left

Mounting Position only applies when Encoder is Posidyne Mounted.

Resolution (4,5)

- 6** **0** = 60 PPR (Pulses per Revolution) (5/8" to 1-3/4" Shaft Diameter)
- 9** **0** = 90 PPR (Pulses per Revolution) (2-3/8" to 2-3/4" Shaft Diameter)

Shaft Size (6)

- A** = 5/8" Dia.\*
- C** = 7/8" Dia.\*
- D** = 1-1/8" Dia.
- E** = 1-3/8" Dia.
- F** = 1-5/8" Dia.
- G** = 1-3/4" Dia.
- H** = 2-3/8" Dia.
- J** = 2-3/4" Dia.

\* Available Shaft Sizes for Double C-Face Encoders.

Posidyne Mounted Shaft Size (6) Availability

Shaft Size	Posidyne Size								
	1.5	02	2.5	03	05	10	11	14	20
5/8	X	---	---	---	---	---	---	---	---
7/8	X	---	---	---	---	---	---	---	---
1-1/8	X	X	---	---	---	---	---	---	---
1-3/8	---	---	X	X	---	---	---	---	---
1-5/8	---	---	---	---	X	---	---	---	---
1-3/4	---	---	---	---	---	X	---	---	---
2-3/8	---	---	---	---	---	---	X	X	---
2-3/4	---	---	---	---	---	---	---	---	X