

APPLICATION BULLETIN



APPLICATION: Reversing Drive

INDUSTRY: Roofing Shingles, Bag Products, Etc.

PRODUCT: Oil Shear *Posidyne* Clutch Only

REVERSING DRIVE

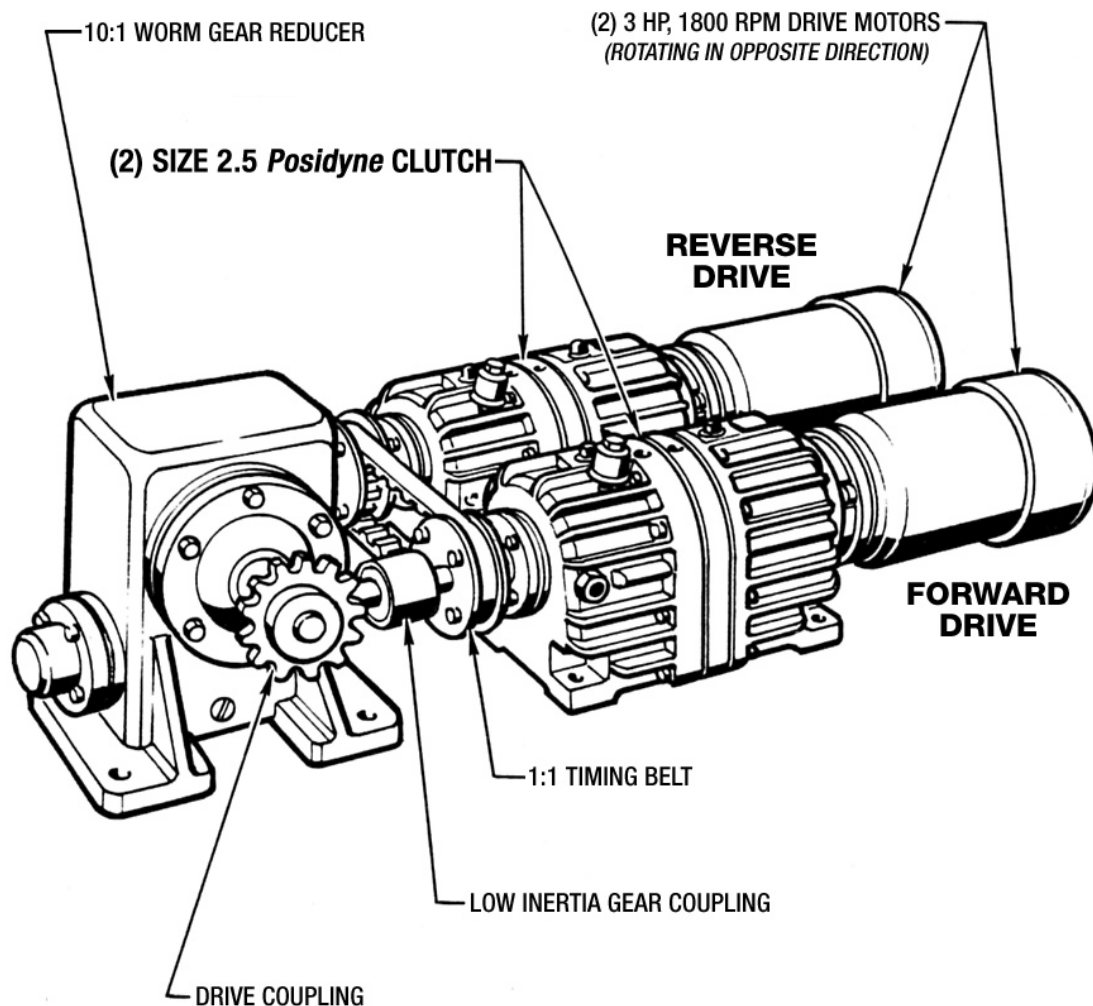

REVERSING DRIVE

WHERE THEY ARE USED: The Reversing Drive is used where a belt drive is reversed to turn a bundle or bag 90 degrees for forming interlocking layers going into a palletizer.

HOW THEY WORK: Normally three belts are used to convey the product. Two are at a higher level than the middle one. One outside belt is connected to the reversing drive. When the belt is reversed the product is turned and dropped onto the lower middle belt.

The **Posidyne** Clutches are driven by two motors running in opposite directions. The output shafts are connected by means of a timing belt so either clutch can drive the gear reducer. Engaging one clutch turns the drive in a clockwise direction, engaging the other drive engages counterclockwise rotation. A brake is not usually required for these types of applications, however if it is necessary, SCP logic (Self Centering Piston) will be required for the **Posidyne**.

PROBLEMS SOLVED: The totally enclosed **Posidyne** Clutch is impervious to the abrasive dust and dirt common with many of the kinds of products used in this application. Instant reversing is available at high cycle rates with the multiple disc, oil shear design. The high power and torque of reversing the motors are also eliminated by leaving the motors running constantly in one direction.

IMPORTANT FEATURES:

- **Oil Shear** technology and innovative friction materials provide smooth controlled torque for quick smooth acceleration.
- Excellent static to dynamic torque relationship for smooth acceleration.
- Totally enclosed, oil cooled unit for long service life and low maintenance.
- Quick brake response to stop the frame in case of a web break.



FORCE CONTROL INDUSTRIES, INC.

3660 Dixie Highway Fairfield, Ohio 45014

Phone: 513-868-0900 Fax: 513-868-2105

E-Mail: info@forcecontrol.com Web: www.forcecontrol.com