

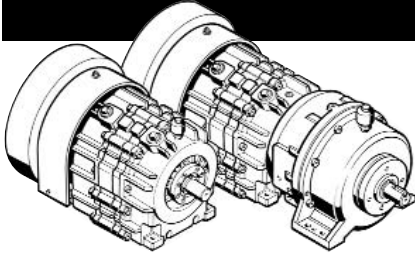

Sizes 11, 20 & 20P Posidyne INDEXING DRIVE INSTALLATION MANUAL



INSTALLATION



Sizes 11 and 20 *Posidyne* Indexing Clutch/Brake Drive without a Planetary Gear Reducer.

Size 20P *Posidyne* Indexing Clutch/Brake Drive with a Planetary Gear Reducer

A. RECEIVING THE DRIVE

Check the drive for shortage or damage immediately after arrival. Prompt reporting to the carrier's agent, with notations made on the freight bill, will expedite satisfactory adjustment by the carrier. When unloading or handling the drive, keep it upright. All Drives are filled with oil, ready to run, when shipped except drive units that have an external cooling system. However, before placing the unit in service or storage, check the oil levels to make sure none has spilled out in transit. Add oil if necessary. (Refer to Section 4 - Lubrication.)

WARNING

Remove the (2) red plastic pipe plugs located in the top of the Output Housing and Planetary Gear Box Housing and install the (2) Air Breathers (#45). Failure to do so can seriously damage the Drive Unit and void the warranty.

If the drive is not to be installed and operated soon after arrival, store it in a clean, dry place having slow, moderate change in ambient temperature.

B. MOUNTING THE DRIVE

1. The *Posidyne* Indexing Drive should be mounted on a firm, level base or foundation, common with both the driving and driven components.
2. Use SAE Grade 5 Hex Hd. Cap Screws to bolt the drive securely into place. Before tightening down the bolts, check the flatness of your existing base or frame. If a .005" Feeler Gauge can be inserted under any one of the four mounting feet with the mounting screws just started (but not tightened down) into the mounting holes, shimming procedure must be followed to compensate for any warping in the base.
3. If the input or output shaft is to be directly coupled, use only a flexible coupling (with horsepower service factor 3 to 1) to take care of maximum torque requirements. Make sure that the shafts to be coupled are concentric within 0.005 in. TIR. Check for horizontal, vertical and angular misalignment. Use shims as necessary to correct.

CAUTION:

Do not drive couplings or bushings on shaft.

4. If the Drive is to be connected through a belt, chain or gear drive, locate as close as possible to the housing to minimize overhung loads. Make sure that the sheaves, sprockets or gears are in line and that the shafts are parallel.

5. After the machinery has been in operation for a few hours, make sure that all mounting bolts are tight and recheck the alignment of all components.
6. After machinery has been in operation for 40 hours check the mounting bolts and tighten if necessary.

C. MOUNTING SIZE 20P *Posidyne* WITH PLANETARY GEAR REDUCER

The primary attachment to the machine frame or base must be done off the (4) mounting holes on the Planetary Gear Reducer. The (2) mounting feet on the *Posidyne* Output Housing are not used. A nominal 1/2" Spacer plus shims has to be used under the *Posidyne* Input Housing feet to take up the gap for vertical alignment. (See *Figure 2* for Mounting Hole Layout.) After final installation and alignment to driving and driven machinery is completed, (2) removable dowel pins must be installed under the Planetary Gear Reducer feet. (See Section E on next page for procedure.)

D. FLYWHEEL INSTALLATION

(See *Figure 1*)

1. If your drive is fan cooled then remove the Fan (#543) from the Flywheel (#542) by taking out the (8) Screws (#475).
Also make sure the Fan Shroud (#24) is mounted to the Input Housing.
2. Make sure the Locking Assembly (#540) is in the bore of the Flywheel.
3. Cut a wood 2x4 to an 8" length and drill a 17/32" hole in the center.
4. Install a 1/2"-13 x 8" Lg "all thread rod" into the end of the input shaft until it bottoms out.

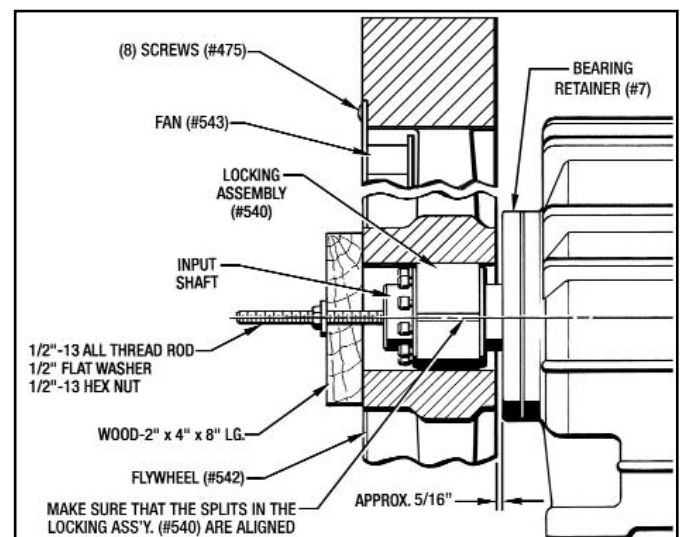

Figure 1 - Installing Flywheel on Input shaft

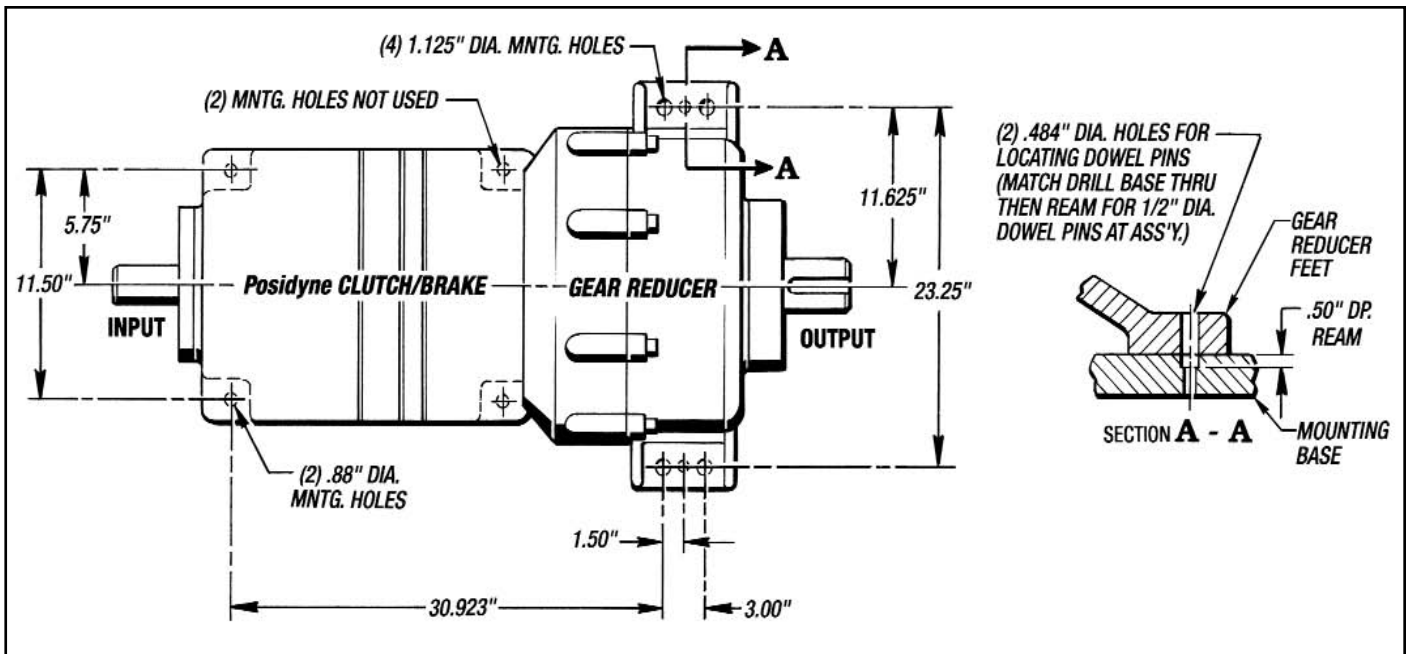

Figure 2 - Size 20P Posidyne Mounting Hole Layout and Mounting Dowel Pins Installation

5. With an overhead crane and soft sling position the Flywheel on the end of the input shaft.
6. Place the 2x4, 1/2" Flat Washer, and a 1/2"-13 Nut onto the threaded rod and tighten the hex nut so it pushes the Flywheel onto the input shaft until it is approx. 1/8" from the Fan Shroud (#24) or 5/16" from the Bearing Retainer (#7) (See Figure 1)
7. Remove the 2x4, Washer, Nut and Threaded Rod from the input shaft after the Flywheel is in position. Also remove the lifting strap from the Flywheel.
8. Tighten up the B-Loc Locking Assembly (#540) according to manufacturers specifications. (See the B-Loc Installation Sheet furnished with the Locking Assembly.)
9. Reinstall Cooling Fan (#543) into the Flywheel.

E. INSTALLING MOUNTING DOWEL PINS

(Size 20P Posidyne With Planetary Gear Reducer)

1. Drill (2) .484" Dia. holes through the machine base, using the (2) .484" Dia. holes in the feet of the Gear Reducer Main Housing (#800) as pilot holes as shown in Figure 2.

NOTE: Drilling through the machine base will facilitate removal of dowel pins when drive has to be removed for servicing.

2. Final ream both holes to a light clearance fit for 1/2" Dowel Pins. Install (2) 1/2" x 1" Lg. Removable Dowel Pins.

IMPORTANT: Do not Loc-Tite these Dowel Pins.

F. INSTALLING PNEUMATIC SYSTEM

(See Figures 3 and 4)

• With Manifold Mounted Control Valve and Furnished Pneumatic Accumulator Assembly

Most of the Indexing Drives are furnished with a Manifold Mounted Control Valve and an Accumulator Assembly because of the quick response time required.

Both the Control Valve and the Accumulator Assembly is shipped with all the fittings attached as shown in Figure 3.

An adequate length of 3/8" I.D. hose is supplied for the Clutch Pressure Hose and the Brake Pressure Hose. Also an adequate length of 1/4" I.D. is furnished for the Pilot Pressure. These will have to be measured and cut-to-length. All hose fittings are of the "Push-Loc" type. **Installed hoses are not to exceed 10 feet in length.**

1. Install the Pneumatic Accumulator Assembly as close as possible to the Posidyne Clutch/Brake and connect the hoses to the Manifold Mounted Control Valve as shown in Figure 3

• Customer Furnished Control Valve

Figure 4 illustrates a typical pneumatic system for the Posidyne Indexing Drive.

Note the following when planning and installing the air system:

1. Use direct acting solenoid air valves or pilot operated valves to give the response speed required. Locate the valves as close as possible to the air inlets on the drive. The valves may be installed directly on the drive if they are supported. Be sure to use valves of at least 2.0 Cv.
2. The optional accumulator should be used for quick response, particularly if the air line loss and the nature of the air supply is such that recovery is slow. Size the accumulator to be at least 10 times the air required per engagement (See Table 1 Below.)

Table 1 - Accumulator Size

Posidyne Size	Volume of Air Required per Engagement (In ³)	(10 x Required Air) Accumulator Size (In ³)
11	15	150
20 & 20P	23	230

Manifold Mounted Control Valve (Size 11 Posidyne Indexing Drive)

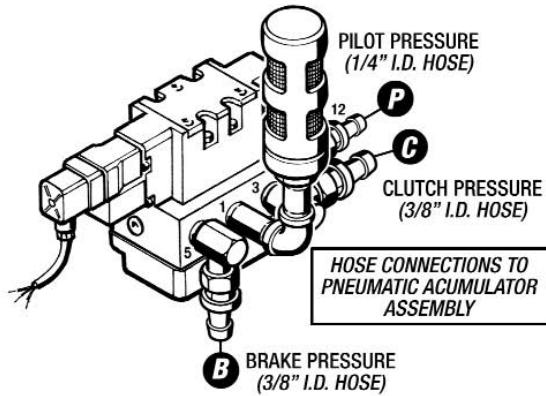

(Size 20 & 20P Posidyne Indexing Drive)

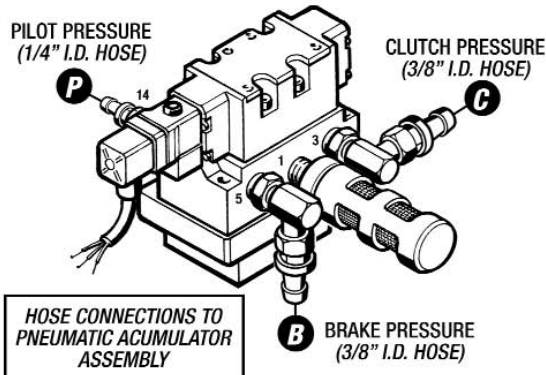

Pneumatic Accumulator Assembly

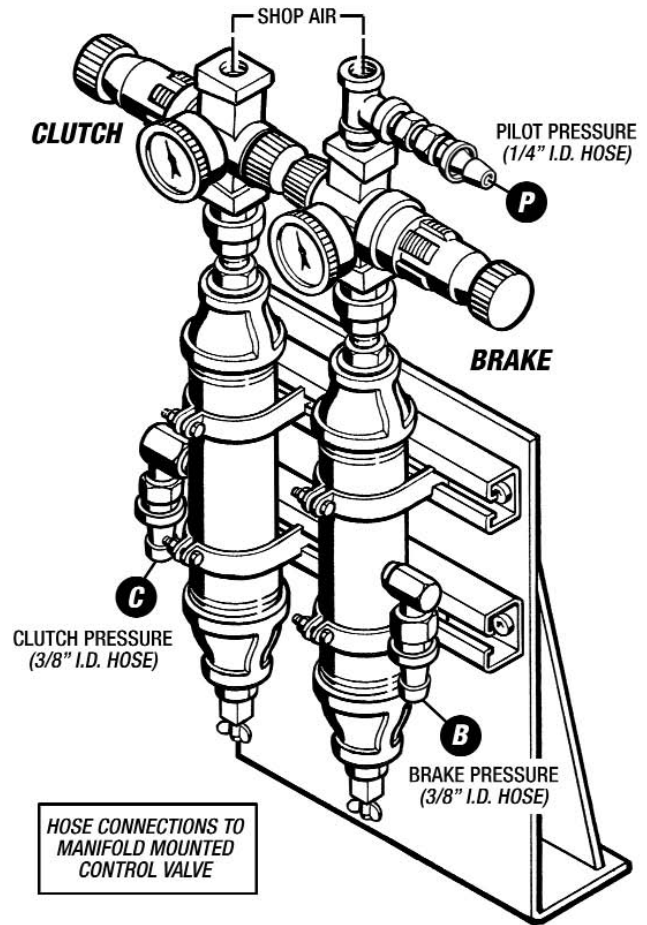

Figure 3 - Pneumatic System

- The air pressure regulators should be sized and set to provide the required Operating Torque. **Table 2** shows the Max. Air Pressure and Max. Torque for the Clutch and Air Assist Brake. Adjust your air pressure to the 55% setting as a starting point. Increase or Decrease the air pressure, from that point, to obtain your desired Operating Torque.

Table 2 - Setting Operating Torque

Posidyne Size	Static Clutch Torque (Lb. In.)		Static Brake Torque With Max. Air Assist (Lb. In.)	
	@ Max PSIG	55% of Max. Ratings	@ Max PSIG	55% of Max. Ratings
11	10314 @ 60	5673 @ 33	7778 @ 35	4278 @ 19
20	15779 @ 60	8678 @ 33	16188 @ 35	8903 @ 19
20P	59644 @ 60	32804 @ 33	52625 @ 35	28944 @ 10

- Pressure is directly proportional to torque. Use only the pressure necessary. (The clutch is not a variable speed drive. Do not let it slip for extended periods.) **Consult the Factory for the correct Clutch and Brake Pressures for your specific application.**

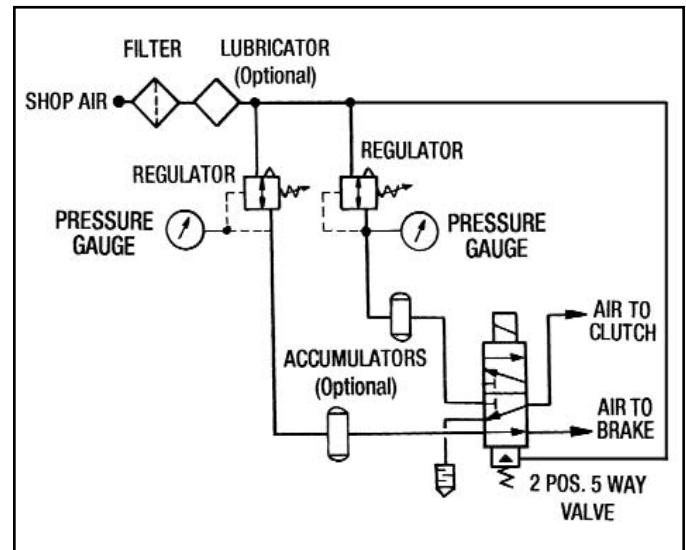

Figure 4 - Pneumatic Schematic

- After using the drive for a few weeks the acceleration time may increase. Increasing the air pressure will restore the acceleration.

G. INSTALLING EXTERNAL COOLING SYSTEM

(See Figure 5)

1. Install Heat Exchanger (#4), Filter (#15) and the Cooling Pump and Motor Assembly as close as possible to the drive unit.
2. Remove any necessary pipe plugs. Cut hose lengths to suit and install as shown in Figure 5.

NOTE - All Hose Fittings are *Parker Reusable 20 Series Hose Fittings*.

3. Fill drive unit with oil as specified in the Lubrication Section.

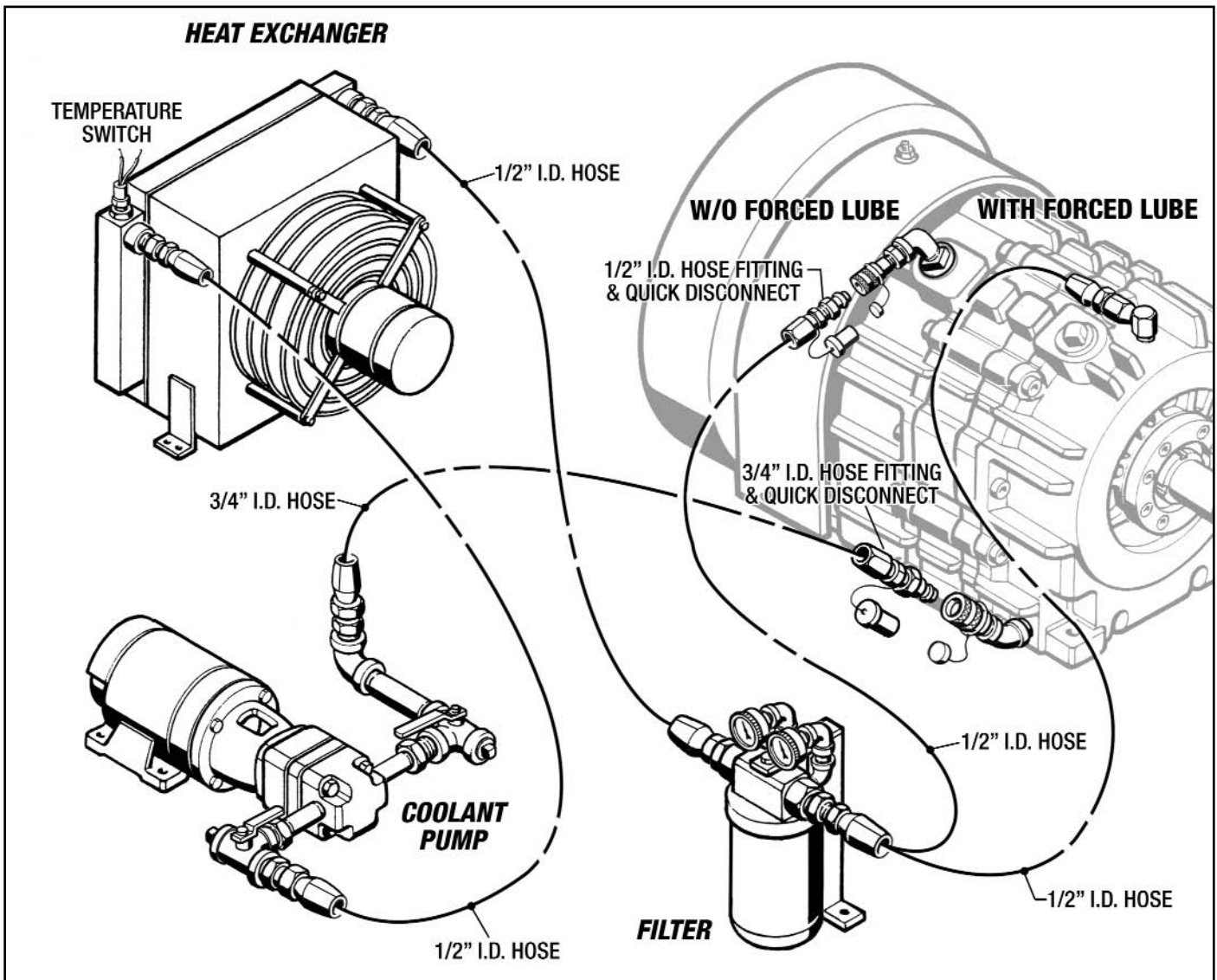

Figure 5 - Installing External Cooling System

H. INSTALLING THE CLPC CONTROL

See CLPC Operation and Service Manual for installation, operation and servicing instructions.

LUBRICATION

A. CHECKING THE OIL LEVEL

(See Figure 6)

When the drive is installed and weekly thereafter, or until experience dictates otherwise, check the oil level. Always check the oil level with the drive at room temperature and while it is not running.

The drive has an Oil Sight Gauge (#46) located at the output end of the drive. The oil level is to be at the center of the gauge with the drive motor turned off.

The Planetary Gear Box has a Pipe Plug (#92) in the side of the Transfer Case. Remove this pipe plug to check the oil level. The oil level is to be at the bottom of the hole.

B. CHANGING THE OIL

(See Figures 6 and 7)

IMPORTANT - Open the disconnects to the drive motors before attempting to change the oil.

• Posidyne Unit Without External Heat Exchanger

Every three months completely drain the oil from the Posidyne Drive by removing a Drain Plug (#73). Drain the oil into a suitable container. If the Sight Gauge (#46) is dirty, it should be removed and cleaned.

Re-install the Drain Plug (#73), Sight Gauge (#46) and remove

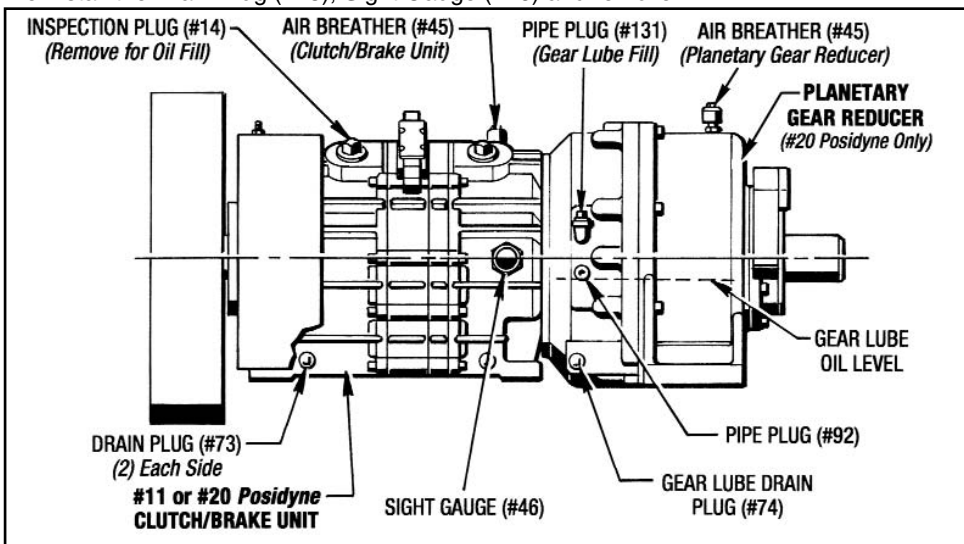

Figure 6- Lubrication

the Inspection Plug (#14) from the Input Housing. Refill the unit with fresh oil to the center of the Sight Gauge (#46).

NOTE: The capacity of the #11 Posidyne is 10 Qts. (2-1/2 Gal.) and the #20 Posidyne requires 25 Qts. (6-1/4 Gal.) of oil.

CAUTION - Do not overfill the Drive Unit. Excess oil will cause the unit to run hot and possibly over-heat.

• Planetary Gear Reducer

After initial installation drain the oil after 30 days and refill with fresh oil. After first oil change check the level at least once per month and change at least every 12 months.

If the oil in the Planetary Gear Reducer needs replaced then remove the Drain Plug (#74) and drain the oil into a suitable container. Replace this plug after the oil is drained.

Remove Pipe Plugs (#131) and (#92) and fill the Transfer Case until the oil starts to come out the "Oil Level Hole" as shown in Figure 6. The Gear Reducer hold approx. 10 Qts. (2-1/2 Gal.) of Gear Lube. Replace the (2) Pipe Plugs (#131) and (#92).

• Posidyne Unit With External Heat Exchanger

(See Figure 5 and 7)

1. Replacing Filter Element

Check the pressure drop on the (2) Pressure Gauges (#216) with the Cooling Pump turned on to see if the Filter Element (#16) needs to be replaced.

If the pressure drop on the filter outlet is 20 PSI or more, less than the filter inlet, replace the Filter Element (#16). First turn the Cooling Pump off then replace the Element.

2. Draining the Oil (See Figure 7)

a. Remove Pipe Plug (#45) from Valve "A" and connect a suitable hose to drain the oil.

b. Turn the handle on Valve "A" to Drain Position as shown in Figure 7. (Valve "B" should be in Normal Position.) Start the Cooling Pump and drain out all of the oil into a suitable container.

c. Turn Valve "A" back to Normal Position and replace the Pipe Plug (#45).

3. Filling with Oil (See Figure 7)

a. Remove the Pipe Plug (#45) from Valve "B" and connect a suitable fill hose to it.

b. Turn handle on Valve "B" to Fill Position as shown in Figure 7. Make sure that Valve "A" is in Normal Position.

c. Start the Cooling Pump and fill the unit until the oil is in the center of the Sight Gauge (#46) located in the output housing. It should take approx. 27 Qts. to completely fill the system. Turn pump off when filled.

CAUTION - Do not overfill the Drive Unit. Excess oil will cause the unit to run hot and possibly over-heat.

d. Turn handle on Valve "B" back to Normal Position and replace the Pipe Plug (#45).

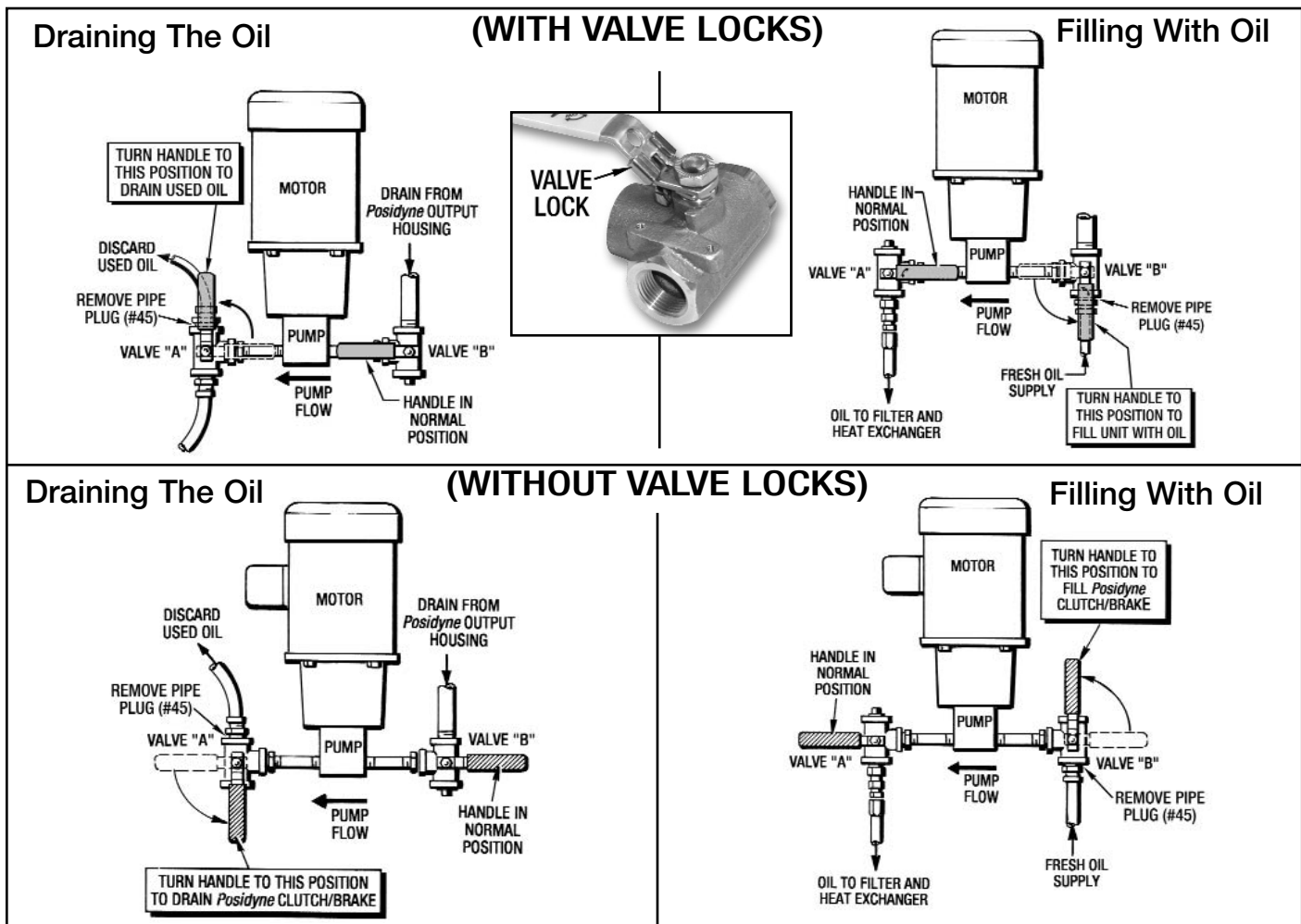

Figure 7 - Valve Positions for Draining and Filling the Oil

C. TYPE OF OIL

Use only Mobil Automatic Transmission Fluid ATF-210 (type "F") or Mobil Multi-purpose Automatic Transmission Fluid for most Posidyne Drive Units. Other fluids may be specified for

special applications. Always use the type of fluid specified on the Name Plate.

The Planetary Gear Reducer uses HD-80W90 Gear Lube.

FACTORY REBUILD SERVICE, MAINTENANCE & MANUALS

A. FACTORY REBUILD SERVICE

A Factory Rebuild Service is offered by Force Control Industries, Inc. Contact our service and sales department at Force Control for additional information.

B. MAINTENANCE & MANUALS

A complete Service Manual and related manuals can be downloaded and printed off of our web site or ordered directly from Force Control.

Go to: www.forcecontrol.com

All of our Catalogs and Service Manuals on the web site are in PDF format and will require Adobe Acrobat Reader 5.0 or later to open them. This Adobe Acrobat Reader can be downloaded from our web site if you do not have it installed on your computer.



FORCE CONTROL INDUSTRIES, INC.

3660 Dixie Highway
Fairfield, Ohio 45014

Phone: 513-868-0900

Fax: 513-868-2105

E-Mail: info@forcecontrol.com

Web Site: www.forcecontrol.com