

502-01/1.5-003-00

SERVICE MANUAL AND REPAIR PARTS FOR 01 and 1.5 *Posidyne*[®] CLUTCH/BRAKE DRIVES

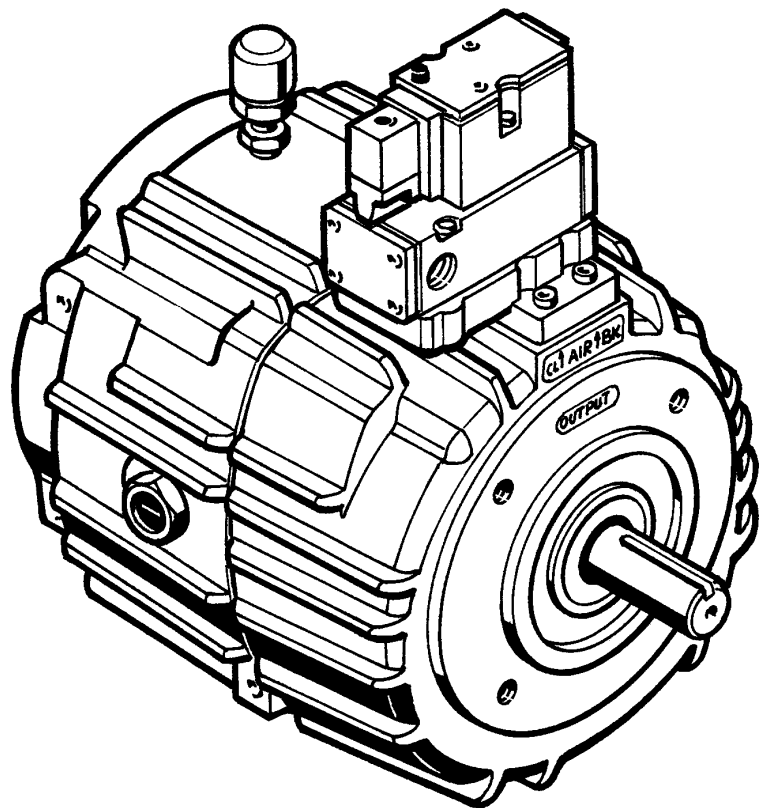

WARNING - Read this manual before any installation, maintenance or operation.



FORCE CONTROL INDUSTRIES, Inc.

**MANUFACTURERS OF MECHANICAL AND
ELECTRICAL POWER TRANSMISSION EQUIPMENT**

Limited Warranty

Force Control Industries, Inc. ("Force Control") warrants its products to be free from defects in material and workmanship under normal and proper use for a period of one year from the date of shipment. Any products purchased from Force Control that upon inspection at Force Control's factory prove to be defective as a result of normal use during the one year period will be repaired or replaced (at Force Controls'option) without any charge for parts or labor. This limited warranty shall be void in regard to (1) any product or part thereof which has been altered or repaired by a buyer without Force Control's previous written consent or (2) any product or part thereof that has been subjected to unusual electrical, physical or mechanical stress, or upon which the original identification marks have been removed or altered. Transportation charges for shipping any product or part thereof that the buyer claims is covered by this limited warranty shall be paid by the buyer. If Force Control determines that any product or part thereof should be repaired or replaced under the terms of this limited warranty it will pay for shipping the repaired or replaced product or part thereof back to the buyer. EXCEPT FOR THE EXPRESS WARRANTY SET OUT ABOVE, FORCE CONTROL DOES NOT GRANT ANY WARRANTIES EITHER EXPRESSED OR IMPLIED, INCLUDING IMPLIED WARRANTIES OF MERCHANTABILITY OR FITNESS FOR USE. The warranty obligation set forth above is in lieu of all obligations or liabilities of Force Control for any damages. Force Control specifically shall not be liable for any costs incurred by the buyer in disconnecting or re-installing any product or part thereof repaired or replace under the limited warranty set out above. FORCE CONTROL EXPRESSLY EXCLUDES ALL LIABILITY FOR ANY INDIRECT OR CONSEQUENTIAL DAMAGES THE BUYER MAY SUSTAIN IN CONNECTION WITH THE DELIVERY, USE, OR PERFORMANCE OF FORCE CONTROL PRODUCTS. Under no circumstances shall any liability for which Force Control is held responsible exceed the selling price to the buyer of the Force Control products that are proven to be defective. This limited warranty may be modified only in writing signed by a duly authorized officer of the company. This limited warranty applies exclusively to Force Control products; warranties for motors and gear reducers and other component parts may be provided by their respective manufactures. Any legal action for breach of any Force Control warranty must be commenced within one year of the date on which the breach is or should have been discovered.

A Return Goods Authorization (RGA) number must be obtained from the factory and clearly marked on the outside of the package before any equipment will be accepted for warranty work. Force Control will pay the shipping costs of returning the owner parts that are covered by warranty.

Force Control believes that the information in this document is accurate. The document has been carefully reviewed for technical accuracy. In the event that technical or typographical errors exist, Force Control reserves the right to make changes to subsequent editions of this document without prior notice to holders of this edition. The reader should consult Force Control if errors are suspected. In no event shall Force Control be liable for any damages arising out of or related to this document or the information contained in it.

01 and 1.5 *Posidyne* CLUTCH/BRAKE

TABLE OF CONTENTS

Section 1

DESCRIPTION and OPERATION

1-1 The Oil Shear Principle.....	1
1-2 Description.....	1
1-3 Operation.....	2

Section 2

SPECIFICATIONS

2-1 Model Designations.....	3
2-2 Operating Specifications.....	3
2-3 Dimensional Specifications.....	4

Section 3

INSTALLATION

3-1 Receiving the Drive Unit	6
3-2 Mounting the Drive Unit	6
A. With Split Quill Input Shaft.....	6
B. With Key Type Quill Input Shaft.....	7
3-3 Pneumatic Hookup.....	7
3-4 Electrical Hookup.....	7

Section 4

LUBRICATION

4-1 Checking the Oil Level.....	8
4-2 Changing the Oil.....	8
4-3 Type of Oil.....	8

Section 5

OPERATIONAL CHECKS

5-1 General Setup Instructions.....	9
5-2 Checking Clutch/Brake Piston Seals	9
5-3 Checking Clutch/Brake Engagement or Input Shaft Vs. Output Shaft Rotation.....	9
5-4 Drive Motors.....	9
5-5 Pneumatic Control.....	9

Section 6

TROUBLESHOOTING

6-1 Troubleshooting Chart.....	10
6-2 Checking Brake and Clutch Stacks for Wear.....	12

Section 7

DISASSEMBLY

7-1 General Disassembly Procedure.....	13
7-2 Disconnecting the C-Face Motor	13
7-3 Disassembly of Position Encoder	13
7-4 Access to the Clutch and Brake Stacks.....	13
7-5 Removing Cooling Fan (#25) from the Input Shaft....	15
7-6 Quill Input Shaft Removal.....	15
A. With Split Clamp Quill Input Shaft.....	15
B. With Key Type Quill Input shaft.....	15
7-7 Quill Input Shaft Disassembly.....	15
7-8 Male Input Shaft Disassembly	15
7-9 Output Shaft Removal and Disassembly.....	16
A. With Split Clamp Quill Input Shaft.....	16
B. With Key Type Quill Input shaft.....	16
7-10 Removing Oil Seals.....	16
7-11 Piston Housing Subassembly Disassembly.....	16

Section 8

CLEANING and INSPECTION

8-1 Cleaning and Inspection.....	18
8-2 Repair and Replacement.....	18

Section 9

REASSEMBLY

9-1 General Reassembly Instructions.....	18
9-2 Reassembly of the Piston Housing Sub-Assembly.....	19
9-3 Output Shaft Reassembly.....	19
9-4 Input Shaft Reassembly.....	20
9-5 Installing Oil Seals into Input and Output Housings.....	21
9-6 Installing Output Shaft into Output Housing.....	21
A. With Split Clamp Quill Input Shaft.....	21
B. Without Split Clamp Quill Input Shaft.....	21
9-7 Measuring and Controlling Stack Height.....	21
9-8 Installing Brake Stack.....	21
9-9 Installing the Piston Housing Assembly.....	22
9-10 Installing Clutch Stack.....	22
9-11 Installing Input Shaft and Input Housing.....	22
A. With Split Clamp Quill Input Shaft.....	22
B. Without Split Clamp Quill Input Shaft.....	23
9-12 Installing Cooling Fan on Input Shaft.....	23
9-13 Final Reassembly.....	23
9-14 Remounting the Drive Unit to the C-Face Motor.....	23

Section 10

ORDERING REPAIR PARTS

10-1 General Information	24
10-2 Drive Motors.....	24
10-3 Factory Rebuild Service.....	24
10-4 Ordering Replacement Parts.....	24
10-5 Name Plate and Model Numbers.....	25

Exploded View Drawings

Figure 10.1 - 01 and 1.5 <i>Posidyne</i> Clutch/Brake Unit (With Split Quill Input Shaft).....	27
Figure 10.2 - 01 and 1.5 <i>Posidyne</i> Clutch/Brake Unit (With Key Type Quill Input Shaft).....	29
Figure 10.3 - Piston Housing and Retainer Sub-Assembly	31
Figure 10.4 - Optional Extended Male Input Shaft.....	33
Figure 10.4 - Optional 8-1/2" AK C-Face Adapter.....	33
Figure 10.5 - Optional Manifold Mounted Control Valves.....	35
Figure 10.5 - Optional Optical Encoder Assembly.....	35
Figure 10.6 - Optional Fan Cooling.....	36
Figure 10.7 - Optional Foot Mounting.....	37
Figure 10.8 - Clutch/Brake Stacks (Vertical Installation)..	38
Figure 10.9 - Vertical Installation Kits.....	39

Special Assembly Tools

Size 01 <i>Posidyne</i> Special Assembly Tools.....	40
Size 1.5 <i>Posidyne</i> Special Assembly Tools.....	43

Section 1

DESCRIPTION and OPERATION

1-1 THE OIL SHEAR PRINCIPLE

Conventional clutches and brakes depend on the friction between solid surfaces operating in air to transmit torque. Friction does the job, but produces a great amount of heat and wear. The *Posidyne* Clutch/Brake units are oil shear drives, with the friction surfaces operating in a bath of oil, the oil molecules tend to cling to each other and to the friction surfaces. As moving and stationary elements are brought together, a thin, but positive film of oil is maintained between them, controlled by the clamping pressure and carefully designed grooves in the elements. Torque is transmitted from one element to the other through the viscous shear of the oil film. So long as there is relative motion between the elements, they are protected by the oil, thus greatly reducing wear. The oil bath also effectively transmits heat away from the friction elements.

1-2 DESCRIPTION

(See Figure 1.1)

In the *Posidyne* Clutch/Brakes, the friction surfaces consist of alternate carbon steel plates and advanced friction material on steel discs. The oil control grooves are molded into the friction material disc surfaces. The discs have internal teeth which mate with a spline on the output shaft for both clutch and brake applications. The steel plates are pinned to the input shaft in the clutch and the housing for the brake when used. The splined sections of the *Posidyne* output shaft contain centrifugal impellers to maintain a positive flow of oil between the discs and plates.

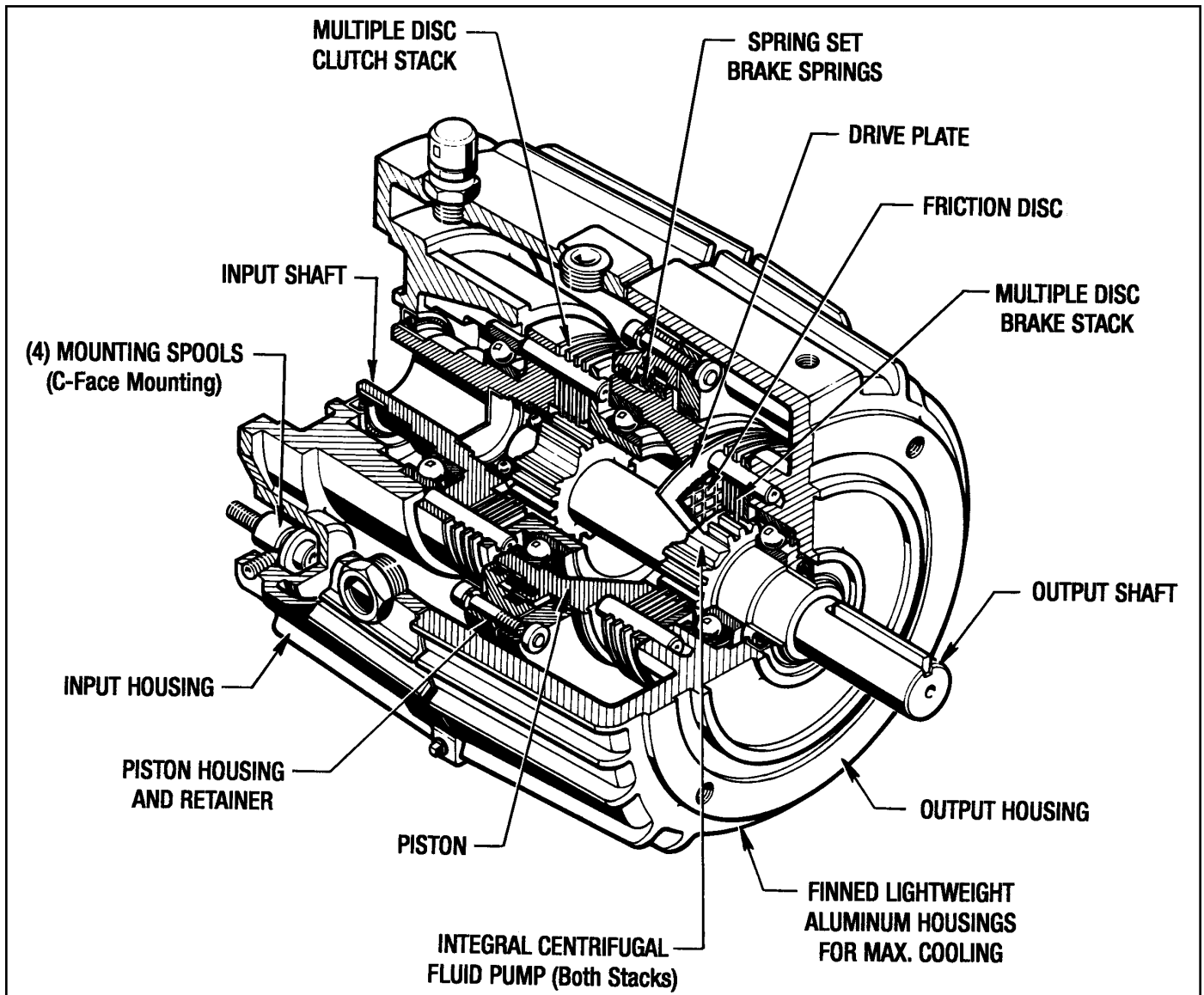

Figure 1.1 - 01 and 1.5 Posidyne Clutch/Brake Description

As noted in Section 2, Specifications, standard *Posidyne* units may be equipped with a clutch and a brake, or a clutch only. The Clutch is normally operated by compressed air, although hydraulic pressure can be used. The *Posidyne* brake may be pressure operated, or it may be spring loaded to operate automatically when the clutch is released.

1-3 OPERATION

The *Posidyne* cross-section (Figure 1.2) shows the drive with the Brake engaged. A nominal braking force is provided by springs located in the Piston Housing. Heavier springs are used to provide a greater braking force, when needed. Air

Assist (as shown), controlled by external valves, also provides a greater braking force. The drive is normally in the Brake Position. The Drive Plates are pinned to the Output Housing and the Friction Discs are splined to the Output Shaft. The Output Shaft is not able to rotate in the Brake Position.

The Clutch is engaged when the air pressure is exhausted from the Brake Port and applied to the Clutch Port. The Piston moves to compress the Clutch Stack on the Input Shaft. The Drive Plates are pinned to the Input Shaft and the Friction Discs are splined to the Output Shaft. This allows both shafts to rotate at the same speed.

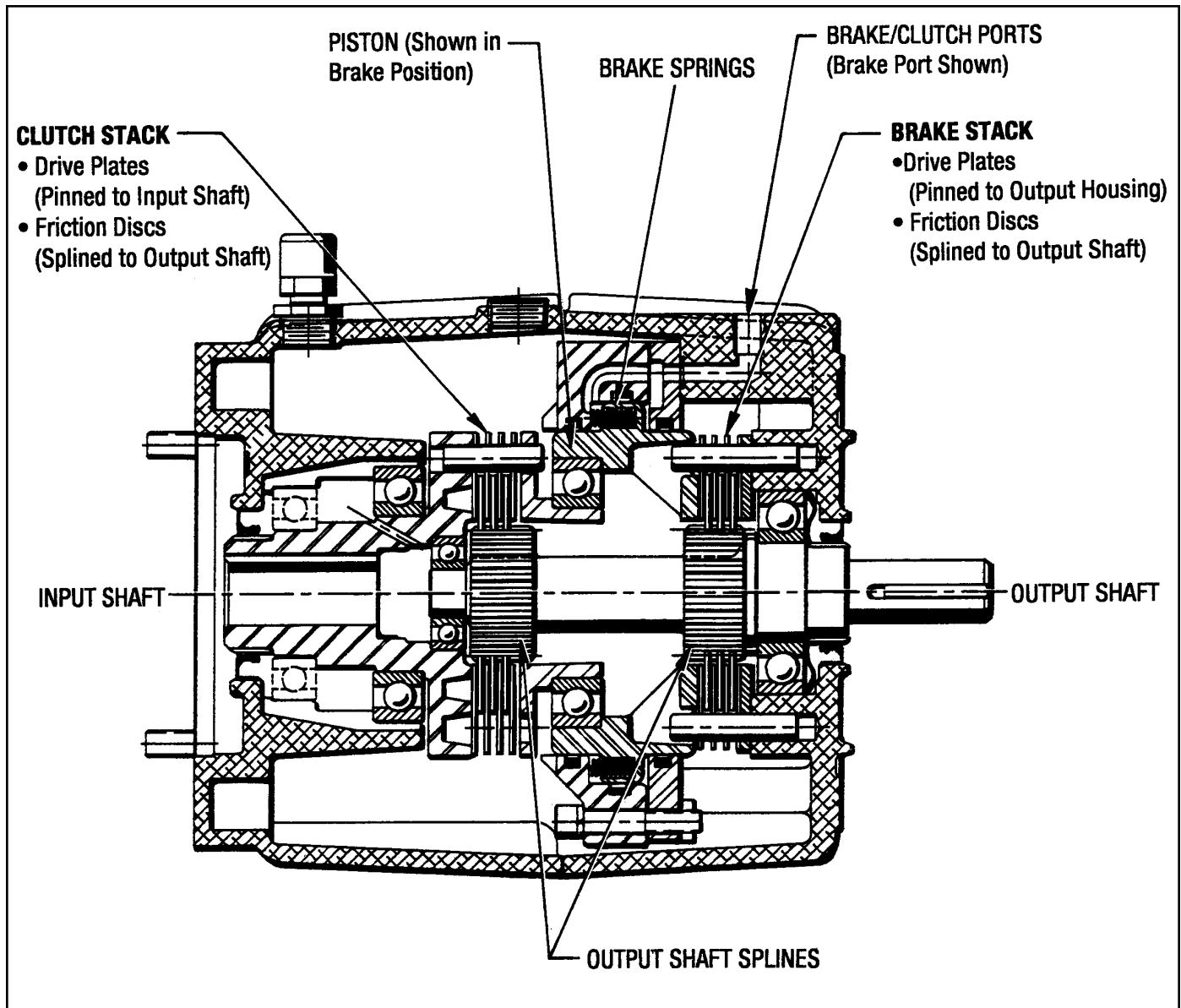

Figure 1.2 - 01 and 1.5 *Posidyne* Clutch/Brake Operation

Section 2 SPECIFICATIONS

2-1 MODEL DESIGNATIONS

The model designations specifies the size (01 and 1.5) and type of unit. The types are:

- S** - Air set clutch, light spring set brake with air assist.
- SA** - Air set clutch, medium spring set brake with air assist.
- A** - Air set clutch, medium spring set brake. (See NOTE following).
- B** - Air set clutch, heavy spring set brake. (See NOTE following).
- C** - Air set clutch, no brake.

NOTE: Type A and B units both have spring actuated brakes. The difference is that type B units have additional springs.

2-2 OPERATING SPECIFICATIONS

Specifications for the *Posidyne* Clutch/Brake Drives are listed in the following Specification Table.

TORQUE RATINGS

The Torque Ratings are based on maximum actuation pressure.

OPERATING SPECIFICATIONS

Size	Logic	Max. Clutch Torque (Lb. In.)			Max.Brake Torque (Lb. In.)					Max RPM	Max KE per Engmt. (Ft. Lbs.)	Avg. Therm. H.P.*		Air Vol. per Engmt. (Cu. In.)	Oil Cap. (Qts.)		Inertia of Cyclic Parts (Lb. Ft. ²)
		Static	Dyn.	*Max Air Pr.	Springs Only		With Air Assist					Cooling			Horiz	Vert	
					Static	Dyn.	Static	Dyn.	*Max Air Pr.			Basic	Fan				
															Horiz.	Vert.	
01	S	108	93	60 psi	11	9	131	113	60 psi	3600	2987	Horiz. .15 .45		.40	1.5	2	.005
	SA	110	95	70 psi	25	22	100	86	38 psi			-----					
	A	100	86	80 psi	33	28	---	---	---			Vert. --- ---					
	B	62	53	80 psi	67	58	---	---	---								
	C	106	91	70 psi	---	---	---	---	---								
	P	104	90	60 psi	---	---	104	90	60 psi								
1.5	S	427	367	60 psi	32	27	484	416	60 psi	3600	11,230	Horiz. .25 .55		.50	2.0	2.5	.012
	SA	387	333	70 psi	110	95	492	423	70 psi			-----					
	A	387	333	70 psi	110	95	---	---	---			Vert. --- ---					
	B	240	206	70 psi	220	189	---	---	---								
	C	427	367	60 psi	---	---	---	---	---								
	P	464	399	70 psi	---	---	464	399	70 psi								

* - Listed air pressures are at maximum. Operating pressures are generally much lower.

OVERHUNG LOAD CAPACITY (Lbs. Pull)**

Size	Male Input Shaft				Output Shaft							
	300 RPM	1200 RPM*	1800 RPM	3600 RPM	300 RPM		1200 RPM		1800 RPM		3600 RPM	
					Without Encoder	With Encoder	Without Encoder	With Encoder	Without Encoder	With Encoder	Without Encoder	With Encoder
01	250	160	140	110	175	99	175	99	175	99	140	79
1.5	275	175	150	120	360	245	360	245	335	235	265	186

** - At midpoint of shaft extension.

2-3 DIMENSIONAL SPECIFICATIONS (Inches)

Size	In/Out Module	Input			Output		Other Dimensions								Foot Mounting					
		FU	FV	Q	U	V	AB	AL	CC1	CC2	C1	C2	D1	O1	E	2F1	2F2	BSV	D2	O2
01	1	7/8	2.13	---	7/8	2.13	4.00	3.63	7.62	---	11.88	---	---	---	3.75	4.50	---	3.62	4.50	9.09
	2	5/8	---	2.19	5/8	2.06	4.00	3.63	7.62	---	---	---	3.31	7.75	---	---	---	---	---	---
	3	7/8	---	2.19	7/8	2.13	4.00	3.63	7.62	---	---	---	3.31	7.75	---	---	---	---	---	---
1.5	1	7/8	2.13	---	7/8	2.13	4.70	4.25	9.00	10.00	13.25	14.25	---	---	3.75	5.38	6.63	3.81	4.50	9.93
	2	5/8	---	2.59	5/8	2.06	4.70	4.25	9.00	10.00	---	---	3.92	9.25	---	---	---	---	---	---
	3	7/8	---	2.59	7/8	2.13	4.70	4.25	9.00	10.00	---	---	3.92	9.25	---	---	---	---	---	---
	4	1-1/8	---	3.12	1-1/8	2.62	4.70	4.25	9.00	---	---	---	3.92	9.25	---	---	---	---	---	---

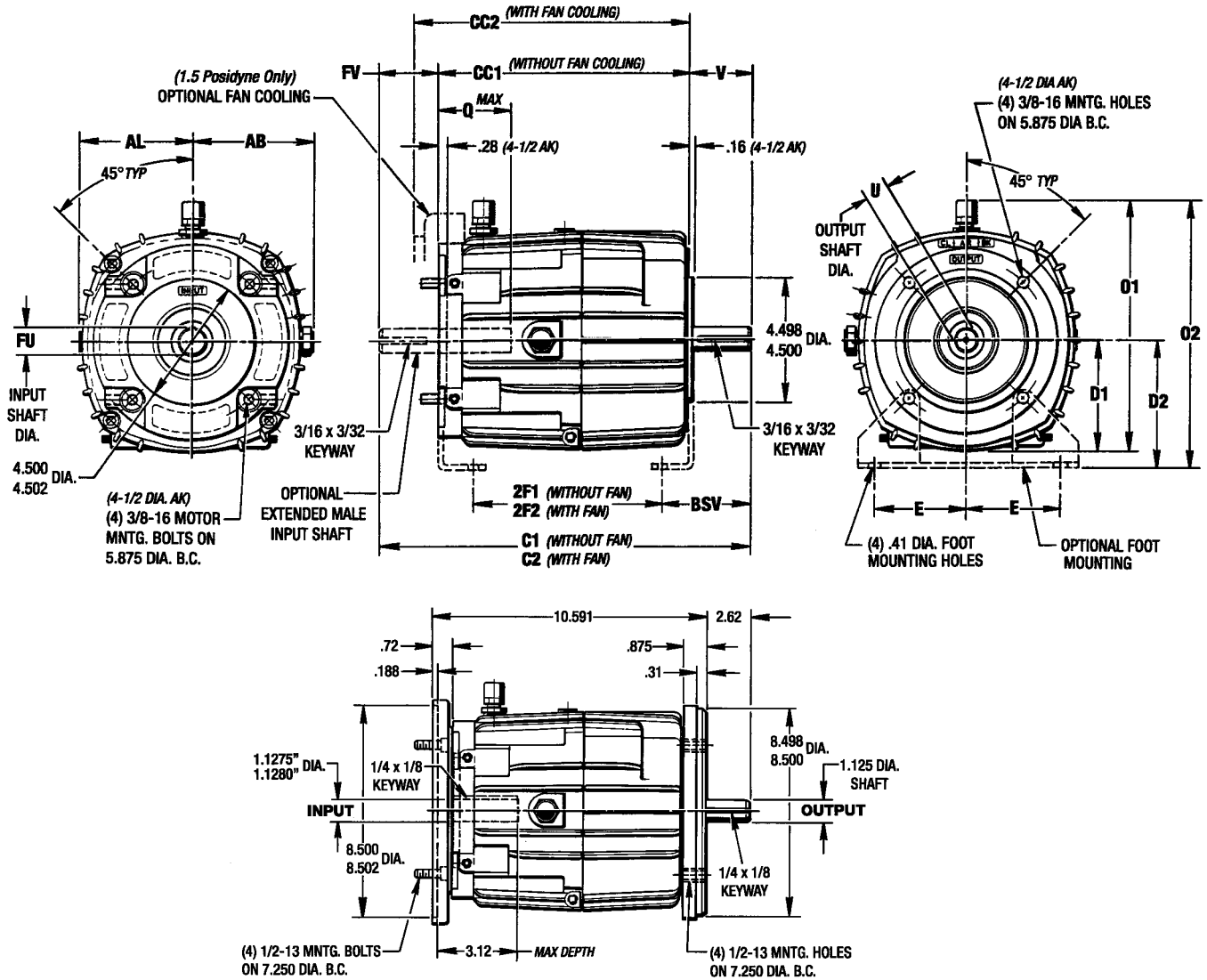

8-1/2" AK C-Face Flange (182 TC and 184 TC Motor Frame)

Dimensions are subject to change without notice. Certified Installation Drawings are available upon request.

DIMENSIONS (With Split Quill Input Shaft, Optical Encoder and Manifold Mounted Control Valve) (Inches)

Size	Input Module	Output Module	Input		Output			Overall Dimensions					
			FU	Q	U	V	BSV	AB	AL	D1	H		L
											Valve with Reg.	Valve W/O Reg.	
01	5	A	5/8	2.19	5/8	2.12	3.62	4.00	3.63	3.31	9.13	7.38	12.08
	6	C	7/8	2.19	7/8	2.16	3.62				9.13	7.38	12.08
1.5	5	A	5/8	2.39	5/8	2.16	3.65	4.70	4.25	3.92	9.75	8.00	13.47
	6	C	7/8	2.39	7/8	2.16	3.62				9.75	8.00	13.50

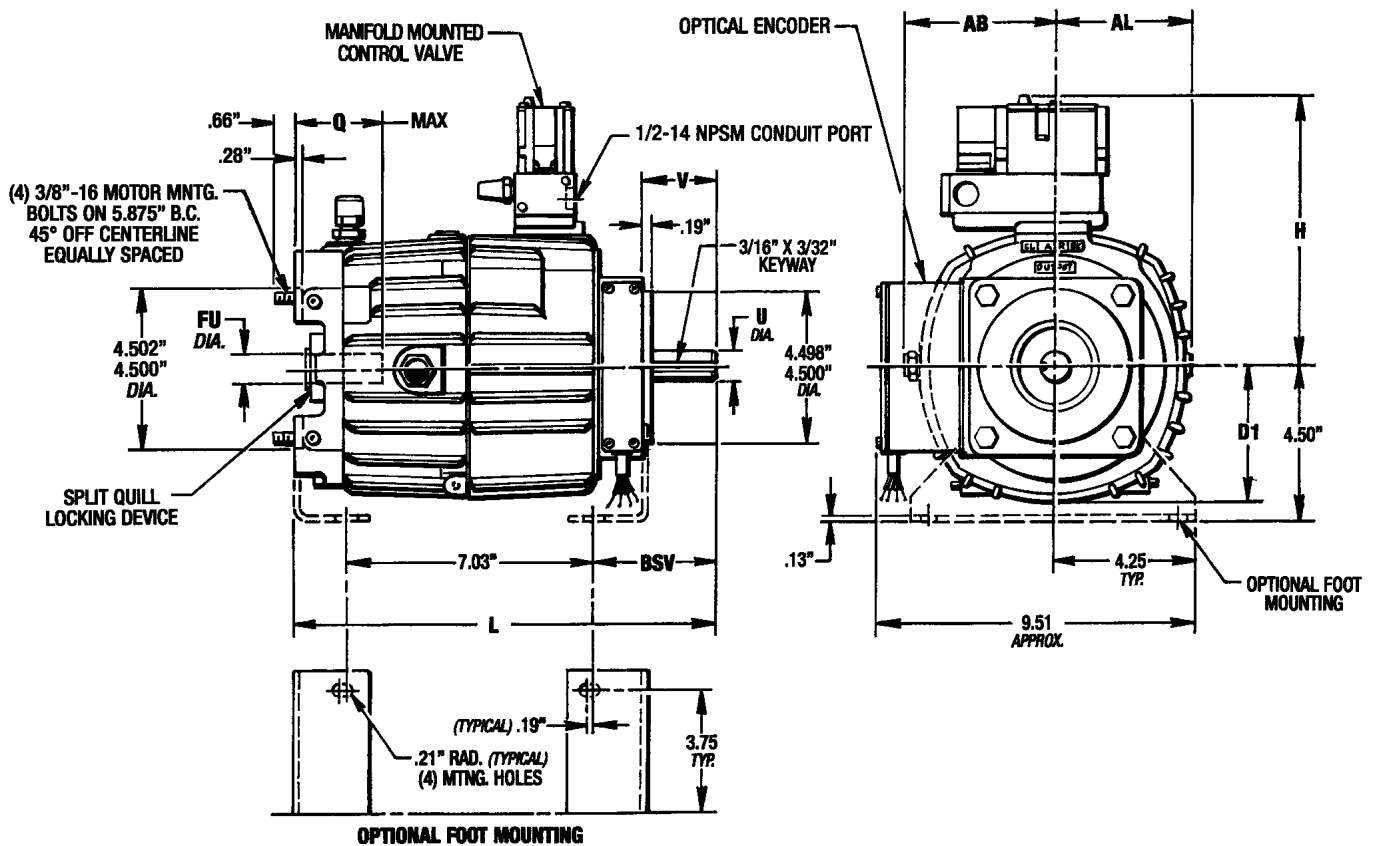

Dimensions are subject to change without notice. Certified Installation Drawings are available upon request.

Section 3 INSTALLATION

3-1 RECEIVING THE DRIVE UNIT

Check the Drive Unit for shortages or damages immediately after arrival. Prompt reporting to the Carrier's Agent, with notations made on the Freight Bill, will expedite any adjustment made by the Carrier.

When unloading or handling the Drive Unit, keep it upright. All Drive Units are filled with oil, ready to run, when shipped. However, before placing the Drive Unit in service or storage, check the oil level to make sure none has spilled out in transit. Add oil if necessary. Refer to Section 4 LUBRICATION.

Remove the red plastic pipe plug from the Reducer Bushing (#73) in the top of the Input Housing and install the Air Breather (#45). **Do not remove the Reducer Bushing.**

If the Drive Unit is not to be installed or operated soon after arrival, store it in a clean dry place having a slow and moderate change in ambient temperature.

3-2 MOUNTING THE DRIVE UNIT

A. With Split Quill Input Shaft

(See Figure 3.1 and 10.1)

1. First make sure that the pilot diameter and mating surfaces of the C-Face Flange is clean and free of all nicks, burrs or anything that would not allow the Drive Unit to seat properly.

2. Install the (4) Mounting Spools (#221), (4) Lockwashers (#265) and (4) Hex Hd. Screws (#305) to the C-Face mounting surface. Apply Blue Loctite to the Screws (#305) and only finger tighten at this time.
3. Loosen the Locking Collar (#281) which is only hand tightened on the Split Quill Input Shaft (#2).
4. Remove the drive motor key if there is one on the motor shaft.

IMPORTANT - Make sure that the motor shaft is thoroughly cleaned but do not lubricate the shaft with any oil. Torque transfer depends on friction between the motor shaft and the split quill input shaft.

5. Loosen the (4) Set Screws (#154) and slip the Drive Unit onto the motor shaft. Push the Drive Unit until it seats on the motor pilot diameter and the (4) Mounting Spools (#221) are seated in the mounting cavities.
6. Carefully remove the Drive Unit without moving the position of the spools. **Torque the Screws (#305) to 12 Ft. Lbs.**
7. Reposition the unit back on the C Face motor flange and tighten the (4) Set Screws (#154). **Torque to 12 Ft. Lbs.**

Visually check to see if the C Face mounting surfaces are snug and tight all the way around.

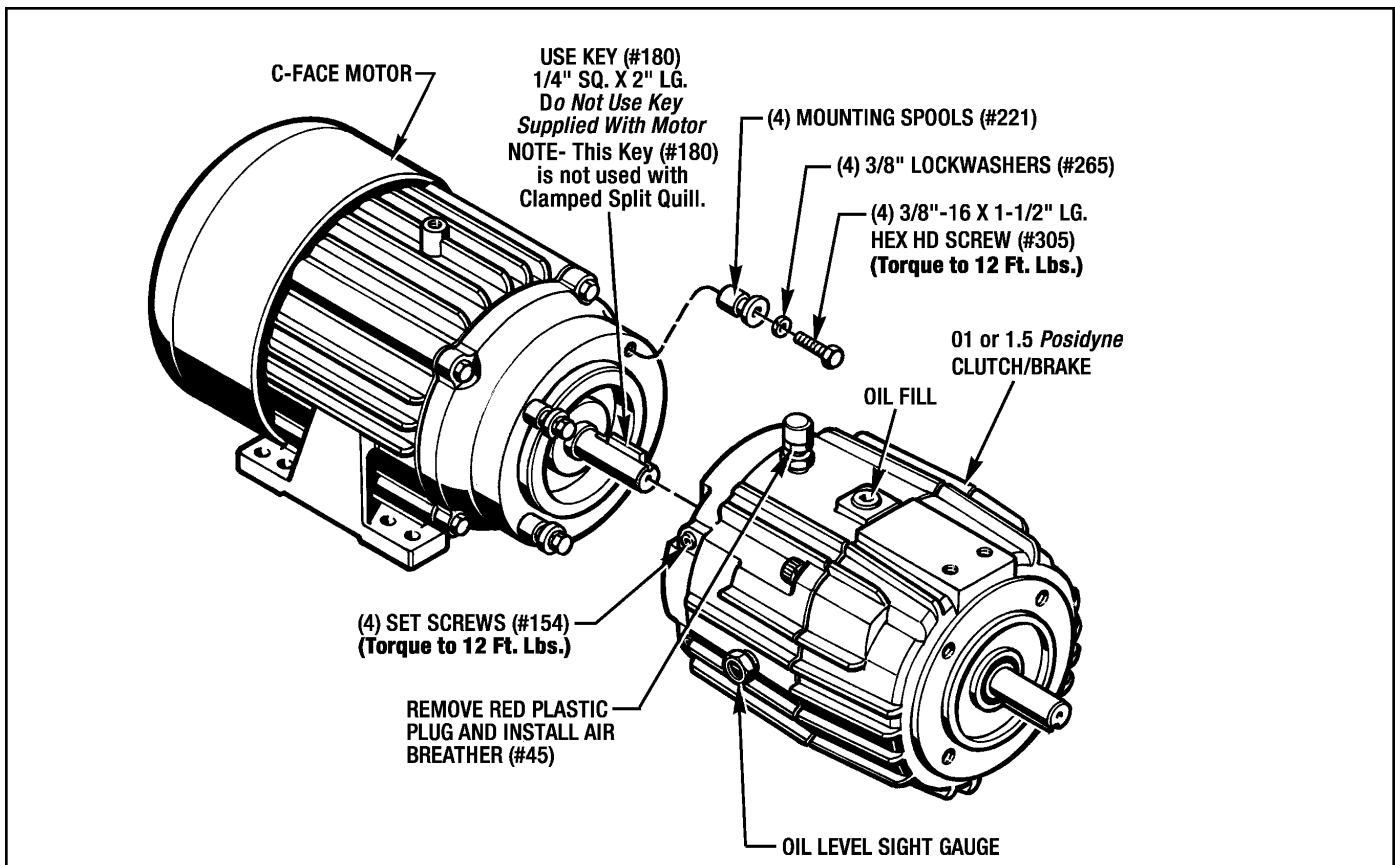

Figure 3.1 - 01 and 1.5 Posidyne Installation

B. With Key Type Quill Input Shaft

(See Figure 3.1 and 10.2)

1. First make sure that the pilot diameter and mating surfaces of the C-Face Flange is clean and free of all nicks, burrs or anything that would not allow the Drive Unit to seat properly.
2. Install the (4) Mounting Spools (#221), (4) Lockwashers (#265) and (4) Hex Hd. Screws (#305) to the C-Face mounting surface. Apply Blue Loctite to the Screws (#305) and only finger tighten at this time.
3. Loosen the (4) Set Screws (#154) and slip the Drive Unit onto the motor shaft. Make sure the Key (#180), which is located in the Quill Input Shaft, is aligned with the motor shaft keyway. Push the Drive Unit until it seats on the motor pilot diameter and the Mounting Spools are seated in the mounting cavities.
4. Carefully remove the Drive Unit without moving the position of the spools. **Torque the Screws (#305) to 12 Ft. Lbs.**
5. Reposition the unit back on the C Face motor flange and tighten the (4) Set Screws (#154). **Torque to 12 Ft. Lbs.**

Visually check to see if the C Face mounting surfaces are snug and tight all the way around.

IMPORTANT NOTE - Whether or not you have optional 8-1/2" AK C-Face Flanges or Fan Cooling, this spool alignment procedure must be maintained to assure proper mounting spool alignment and position.

3-3 PNEUMATIC HOOKUP

Figures 3.2 and 3.3 illustrate typical compressed air systems for the 01 and 1.5 Posidyne Clutch/Brake Unit.

Note the following when planning and installing the air system:

1. Use direct acting solenoid air valves or pilot operated valves to give the response speed required. Locate the valves as close as possible to the air inlets on the Drive. The valves may be installed directly on the drive if they are supported. Manifold mounted control valves are available as an option from the factory. Consult your representative or the Force Control factory.
2. Be sure to use valves of at least .4 Cv.
3. The optional accumulator should be used for quick response, particularly if the air line loss and the nature of the air supply is such that recovery is slow. Size the accumulator to be at least 10 times the air required per engagement. (See Specification Chart.)
4. The air pressure regulator should be sized and set to provide the required torque. (See Torque Specifications.)
5. Pressure is directly proportional to torque. If 80 PSI is not required to drive the machine, use only the air pressure necessary. This will give additional life to the Clutch/Brake Unit.
6. After using the drive for a few weeks the acceleration time may increase. Increasing the air pressure will restore the acceleration time.

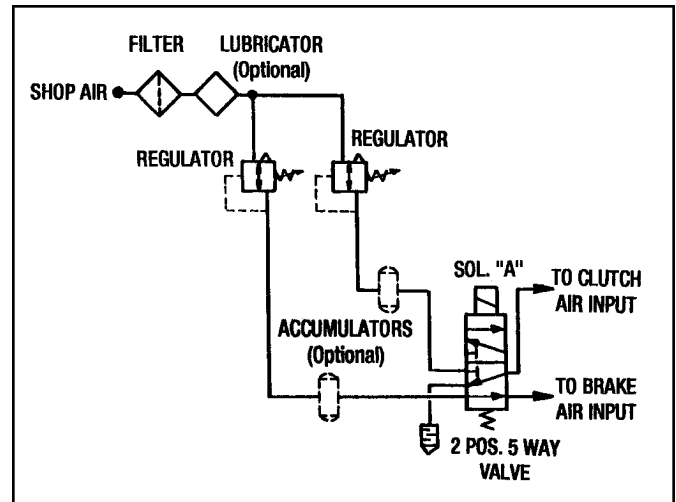

Figure 3.2 - Air operated clutch and brake. (Posidyne - S and SA Logics) with different actuation pressures for the clutch and the brake.

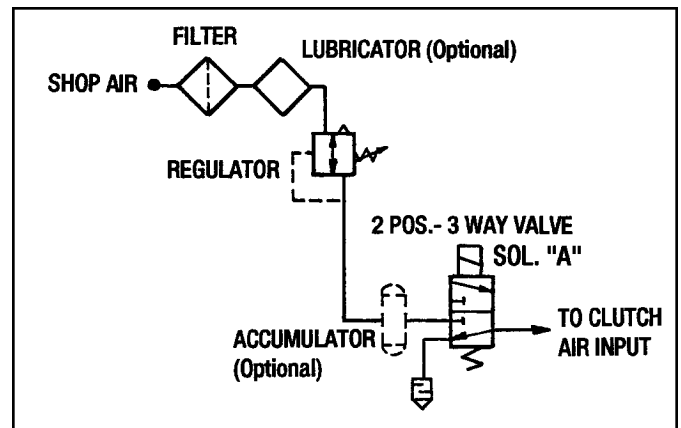

Figure 3.3 - Air operated clutch only and spring set brake. (Posidyne A, B and C Logics)

3-4 ELECTRICAL HOOK-UP

(For Mac 82 Series Control Valves Only)

Use the (2) yellow wires marked "A" for Solenoid "A". The (2) red wires marked "B" are not used for a single clutch unit. They can be cut off and capped.

Section 4 LUBRICATION

4-1 CHECKING THE OIL LEVEL *(See Figure 4.1)*

When the drive is installed and weekly thereafter, or until experience dictates otherwise, check the oil level. Always check the oil level with the drive at room temperature and while it is not running.

The drive has an oil sight gauge located at the input end of the drive. The oil level is to show at the center of the gauge.

4-2 CHANGING THE OIL *(See Figure 4.1)*

IMPORTANT : Open the disconnects to the drive motors before attempting to change the oil.

After the first 30 days of operation completely drain the oil from the drive using the drain plugs provided. If the oil sight glass is dirty it should be removed and cleaned.

Reinstall the drain plugs and refill the drive to the center of the sight glass with fresh oil.

After the first oil change check the oil level and color of the oil at least once per month. Maintain the oil level to the center of the sight glass by adding additional oil as needed. The oil should be changed after every 12 months of operation or sooner if the oil color darkens. High energy applications will usually darken the oil sooner and require more frequent oil changes. Low energy applications will usually not darken the oil.

CAUTION: Do not overfill the Drive Unit. Excess oil will cause the unit to overheat.

4-3 TYPE OF OIL

Use only Mobil Automatic Transmission Fluid ATF-210 (Type "F") or Mobil Multi-purpose Automatic Transmission Fluid for most drives. Other fluids may be specified for special applications. **Always use the type of fluid specified on the Name Plate.**

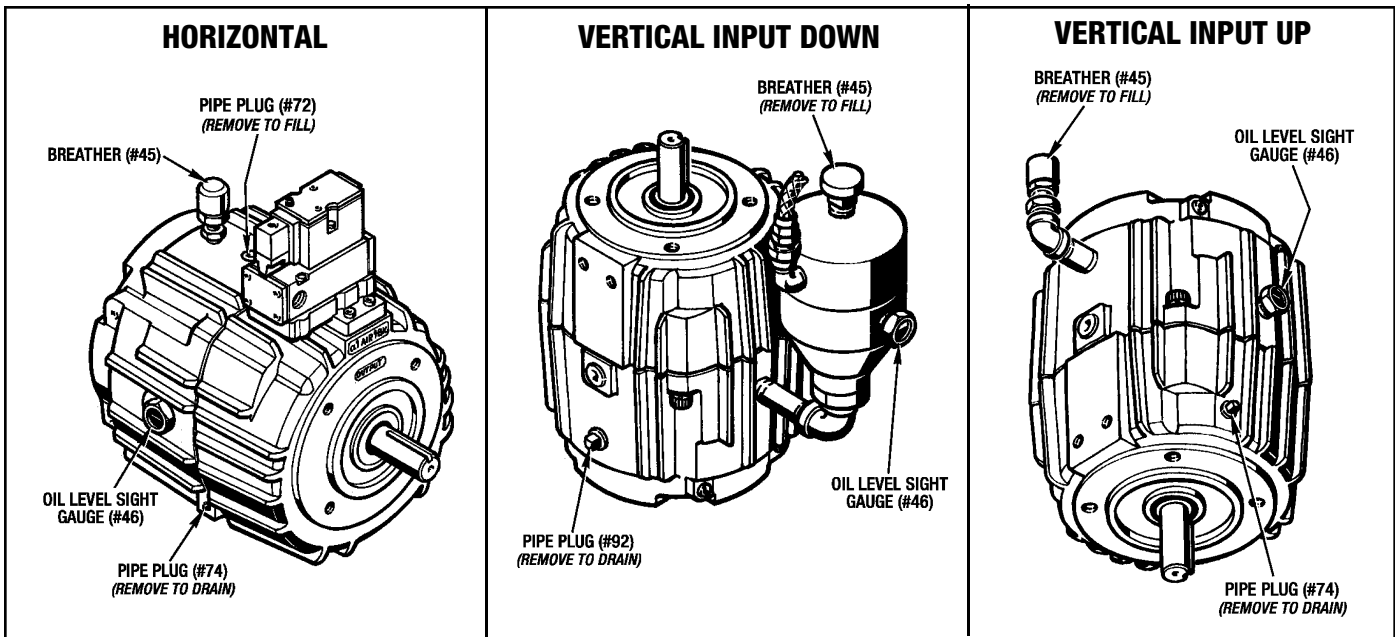

Figure 4.1 - Lubrication

Section 5

OPERATIONAL CHECKS

These Operational Checks are to be made when the Drive Unit is removed from service for repair. Provisions for manually controlled 60 to 80 PSI air pressure must be made for these Operational Checks.

5-1 GENERAL SET-UP INSTRUCTIONS

Assemble a Pneumatic Testing Set-Up similar to the one shown in *Figure 5.1*

5-2 CHECKING CLUTCH AND BRAKE PISTON SEALS

1. Hook the Pneumatic Testing Setup to the Clutch Port and apply shop air to it.
2. Crack the Shut-off Valve until the air pressure reads about 80 PSI on the Pressure Gauge and then quickly shut the air off.
3. Observe the Pressure Gauge to see if the air pressure stays the same, or drops. If the pressure stays the same or drops slowly, the Piston Seals are okay. If the pressure drops rapidly (more than 5 PSI per minute), the Piston Seals are leaking and will need to be replaced.
4. Disconnect the shop air and exhaust the air pressure from the drive unit.

(S and SA Logic Only) "Air Assist " to Brake

5. Hook the Pneumatic Testing Setup to the Brake Port and apply shop air to it.
6. Repeat Steps 2, 3 and 4.

5-3 CHECKING CLUTCH AND BRAKE ENGAGEMENT OR INPUT SHAFT Vs. OUTPUT SHAFT ROTATION.

(WITH C-FACE MOUNTED DRIVE MOTORS)

If the C-Face mounted Drive Motors are still attached, then the Input Shaft is not accessible to be manually rotated to check Clutch/Brake Engagement and Input Shaft vs. Output Shaft rotation.

1. Temporarily hook-up Drive Motor and "Bump" it to check the Clutch or Brake Operating Modes and Output Shaft rotation.

CAUTION: Do not attempt to run motors with the Inspection Plug removed. They must first be replaced.

5-4 DRIVE MOTORS

Check wiring connections against the wiring diagram on the Name Plate. "Bump" the motor and check direction of rotation. Check all connections for tightness.

5-5 PNEUMATIC CONTROL

The Pneumatic Control Operational Checks are to be made with Pneumatic Control valves hooked up.

(See Figures 3.2 and 3.3 for appropriate Pneumatic Control Diagrams.)

1. Shut off air supply, lock it out, and bleed off any trapped air in the system.
2. Insert Diagnostic Pressure Gauges in the air supply between the control valves and the drive. Turn air supply back on.
3. Activate Solenoid Control Valves for desired function.
 - A. Clutch Drive
 - B. Brake "Air Assist"
4. Check air pressure with installed diagnostic pressure gauges for each function.
5. Check all electrical connections and the solenoid operation per manufacturer's specifications.

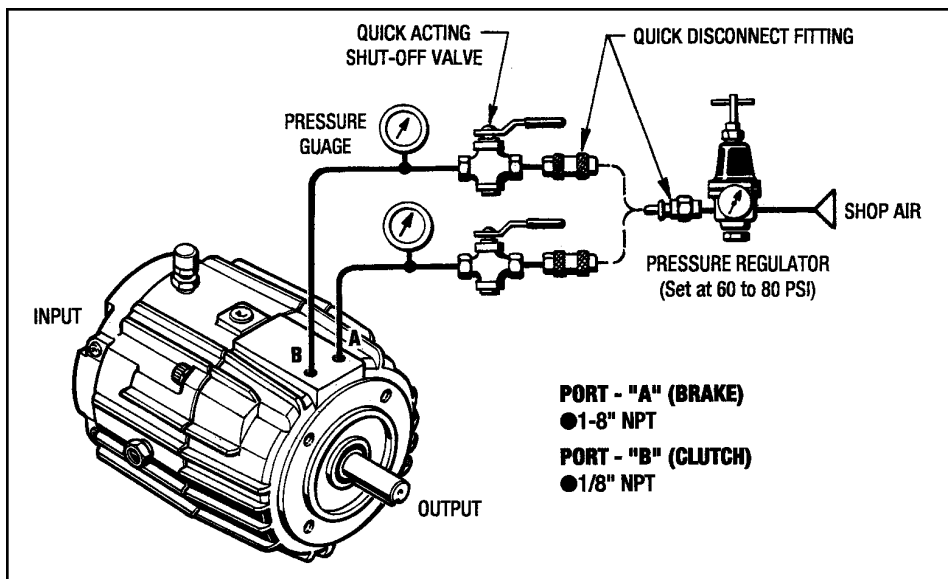

Figure 5.1 - Pneumatic Testing Set-Up

Section 6 TROUBLESHOOTING

6-1 TROUBLESHOOTING CHART

TROUBLE	POSSIBLE CAUSE	REMEDY
Both clutch and brake fail to engage properly.	Electrical control circuit.	Check control circuit.
	Low air pressure.	Increase air pressure.**
	Air pressure regulator or piping.	Check for improper operation or leaks.
	Worn friction surfaces.	Check parts for wear and replace if necessary. (See Section 6-2)
Clutch fails to engage properly.	Electrical control circuit.	Check control circuit.
	Valve not functioning properly.	Check valve operation. Replace if necessary.
	Internal air leakage.	Check and replace O-Rings and Liners if necessary.
	Low air pressure	Increase air pressure.**
	Worn friction surfaces.	Check parts for wear and replace if necessary. (See Section 6-2)
Picks up load too quickly.	Air pressure too high.	Reduce air pressure.
	Low oil level.	Check oil level and add if necessary.
Clutch fails to disengage properly.	Electrical control circuit.	Check control circuit.
	Valve not functioning properly.	Check and replace valve if necessary.
	Piston sticking-broken return springs.	Disassemble to extent necessary and inspect for damaged parts.
Noise and vibration	Mounted on poor foundation.	Improve installation. Tighten foot bolts.
	Misaligned couplings.	Recheck alignment.
	Damaged bearings.	Disassemble to extent necessary and inspect for damaged bearings.
<p>Noise without load (With C-Face Motor) Slight noise or rattling sound in the input end of a C-Face unit when the drive motor is running in an unloaded condition. If the motor is AC variable speed it may be louder at certain speeds.</p>	<p>This is a normal condition. The input shaft is loosely supported in order to compensate for motor shaft run-out and out of round conditions of the pilot.. Some noise can be generated by the movement of the input shaft & drive plates.</p>	<p>This is not a harmful condition to the clutch/brake, and will not cause premature wear.</p>
<p>Noise with load (With C-Face DC Motor) Slight noise or chatter coming from the input end of a C-Face unit when the drive motor is DC and is running in a loaded condition. Noise exists only when the motor is loaded under certain conditions.</p>	<p>This is a normal condition of the motor and is not in the clutch/brake unit. The harmonics of the DC motor is transmitted to the clutch/brake housing and sounds as if it was coming from the clutch/brake.</p>	<p>This is not a harmful condition to the clutch/brake, and will not cause premature wear.</p>

6-1 TROUBLESHOOTING CHART (Continued)

TROUBLE	POSSIBLE CAUSE	REMEDY
Brake fails to engage properly.	Electrical control circuit.	Check control circuit.
	Valve not functioning properly.	Check valve operation. Replace if necessary.
	Internal air leakage.	Check and replace O-Rings and Liners if necessary.
	Low air pressure	Increase air pressure.**
	Worn friction surfaces.	Check parts for wear and replace if necessary. (See Section 6-2)
	Piston sticking	Disassemble to extent necessary and inspect for damaged parts
	Weak or broken brake spring	Replace spring
Drive overheats. (Oil temp. above 225° F.)	Inertia or resistance changed.	Check with Force Control engineering.
	Improper oil level.	Check oil level. Add or drain as needed.
	Fan blocked.	Clean shroud.
Oil leakage	Oil seal lips damaged.	Check to see if oil is leaking around shaft and replace if necessary.
	Gaskets	Tighten all external bolts.
	Poor ventilation.	Remove breather and clean.
Oil leakage out breather.	Damaged seal around piston.	Disassemble and repair.
	Oil level too high.	Drain excess oil.
Excessive shaft end play.	Bearings bad.	Disassemble and replace.
Clutch or brake does not repeat.	Air pressure changed.	Check air pressure and adjust.
	*Oil temperature changed.	Check temperature.
	Resistance in machine changed.	Lubricate bearings.

* - For installations requiring precise starting and stopping, operating temperatures are important. Operating temperatures between 116° F. and 165° F. are recommended. If the transmission fluid is allowed to drop to ambient temperatures overnight, the clutch input shaft should be run approx. 1/2 hour before operating the machinery

** - Maximum Air Pressure. (See Section 2 Specifications Chart for maximum operating air pressure.)

6-2 CHECKING BRAKE and CLUTCH STACKS for WEAR

An easy procedure has been established to visually check the Clutch and Brake Stacks for Wear to determine whether or not they need replaced. There is a **projection** on the back-face of the Piston Housing (#10) to enable you to visually check this. (See Figure 6.1)

CAUTION: Disconnect and lockout all electrical power to the drive motor. This step must be taken to avoid any possibility of personal injury or damage to the unit.

1. Remove the Inspection Plug (#72) from the top of the Input Housing.
2. Apply air pressure to the clutch port and with a flashlight observe the position of Surface "A" of the Piston. If this surface "A" is flush with Surface "C" the Clutch Stack is worn and needs to be replaced. (See Figure 6.1)
3. Apply air to the brake port and again observe the position of Surface "A" of the piston. If it is flush with Surface "B" of the piston housing, the Brake Stack is worn and needs to be replaced. (See Figure 6.1)

IMPORTANT NOTE: Even though the Clutch Stack and the Brake Stack can, individually, be checked for wear, **both stacks should be replaced as a complete set** if either stack is worn and needs replaced. Refer to Section 7 Disassembly and Section 9 Reassembly for Clutch and Brake Stack Replacement.

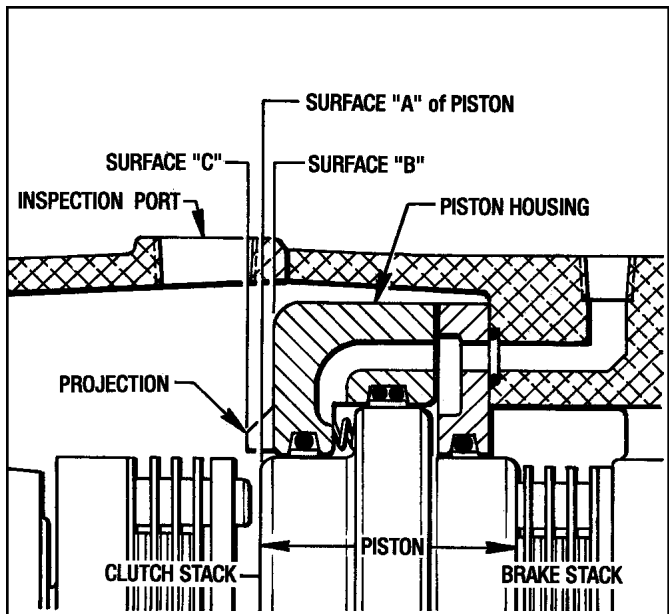

Figure 6.1 - Checking Stack Wear

Section 7 DISASSEMBLY

7-1 GENERAL DISASSEMBLY PROCEDURE

1. Disconnect the Drive Unit and move it to a suitable work area. See Section 7-2 to disconnect the drive motor from the unit.
2. Disconnect all necessary pneumatic piping and valves.
3. Remove the Drain Plugs (#74) from the bottom of the Input Housing and drain out all of the automatic transmission fluid into a suitable container and either save or discard as condition warrants.

NOTE: It is recommended that you set the drive unit on the output end with the output shaft in vertical down position for ease of disassembly. Also supply suitable bracing and clamping to stabilize the drive unit.

The 01 and 1.5 *Posidyne* Drive Unit is comprised of a Main Assembly (Shown on Figures 10.1 or 10.2) and a Piston Housing Sub-Assembly (Shown on Figure 10.3).

The Main Assembly consists of:

1. Input Housing and Input Shaft.
2. Clutch and Brake Stacks.
3. Piston Housing Sub-Assembly, which consists of:
 - a. Piston Housing, Liners and O-Rings.
 - b. Piston, Thrust Plate and Bearing.
 - c. Piston Retainer, Liners and O-Rings.
4. Output Housing and Output Shaft.

7-2 DISCONNECTING THE C-FACE DRIVE MOTOR

(Standard 4-1/2" AK Flange)

(See Figure 7.1 and 10.1 and 10.2)

1. Loosen the (4) Cone Point Set Screws (#154) in the Input Housing enough so the Drive Unit can be removed from the (4) Mounting Spools (#221), which are attached to the drive motor. Loosen the (2) Screws in the Locking Collar (#281). Pull the Drive Unit away from the motor, sliding the motor shaft out of the Quill Input Shaft (#2). (See Figure 7.1)

(1.5 *Posidyne* Only With 8-1/2" AK Flange)

(See Figures 7.1 and 10.4)

1. Loosen the (4) Cone Point Set Screws (#154) in the Input Housing enough so the Drive Unit can be removed from the (4) Mounting Spools (#239), which are attached to the Mounting Flange (#200). Loosen the (2) Screws in the Locking Collar (#281). Pull the Drive Unit away from the flange and motor, sliding the motor shaft out of the Quill Input Shaft (#2).

(With Fan Cooling)

(See Figure 10.6)

1. Loosen the (4) Cone Point Set Screws (#154) in the Input Housing enough so the Drive Unit can be removed from

the (4) Mounting Spools (#239), which are attached to the Fan Shroud (#24) and Drive Motor. Pull the Drive Unit away from the shroud and motor, sliding the motor shaft out of the Quill Input Shaft (#2).

If the Cooling Fan (#25) has to be removed from the Input Shaft (#2), see Section 7-5.

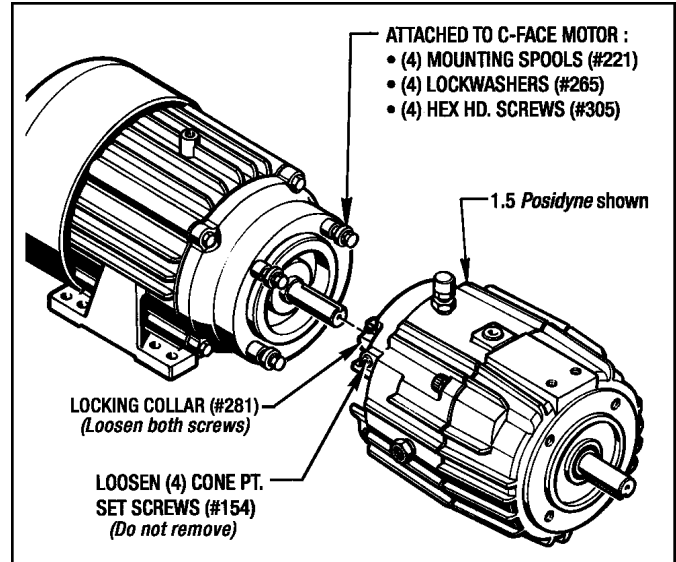

Figure 7.1 - Disconnecting the C-Face Motor

7-3 DISASSEMBLY OF OPTICAL ENCODER

(See Figure 10.5)

NOTE: The Positioning Sensor (#355) can be removed and replaced without having to take the whole assembly off the Clutch/Brake Unit.

1. Remove the Top Cover (#372) by taking out the (2) Cap Screws (#225).
2. Disconnect the wires to the Brad-Harrison Connector (#368).
3. Remove (2) Cap Screws (#226) and lift the Top Housing (#105) off.
4. Pry the Retainer Gasket (#214) out of the top of the Main Housing (#17) and lift the Positioning Sensor (#355) out of the housing.
5. Remove the (4) Screws (#268) and (4) Lockwashers (#257). Pull the Front Cover (#253) and the Main Housing (17) off the Clutch/Brake Unit.
6. Loosen the (2) Set Screws (#57) and remove the Pulse Gear (#186) from the output shaft.

7-4 ACCESS TO THE CLUTCH AND BRAKE STACKS

(See Figure 10.1)

(01 *Posidyne*)

1. Remove the (4) Screws (#69) and (4) Lockwashers (#127) from the Output Housing (#9).

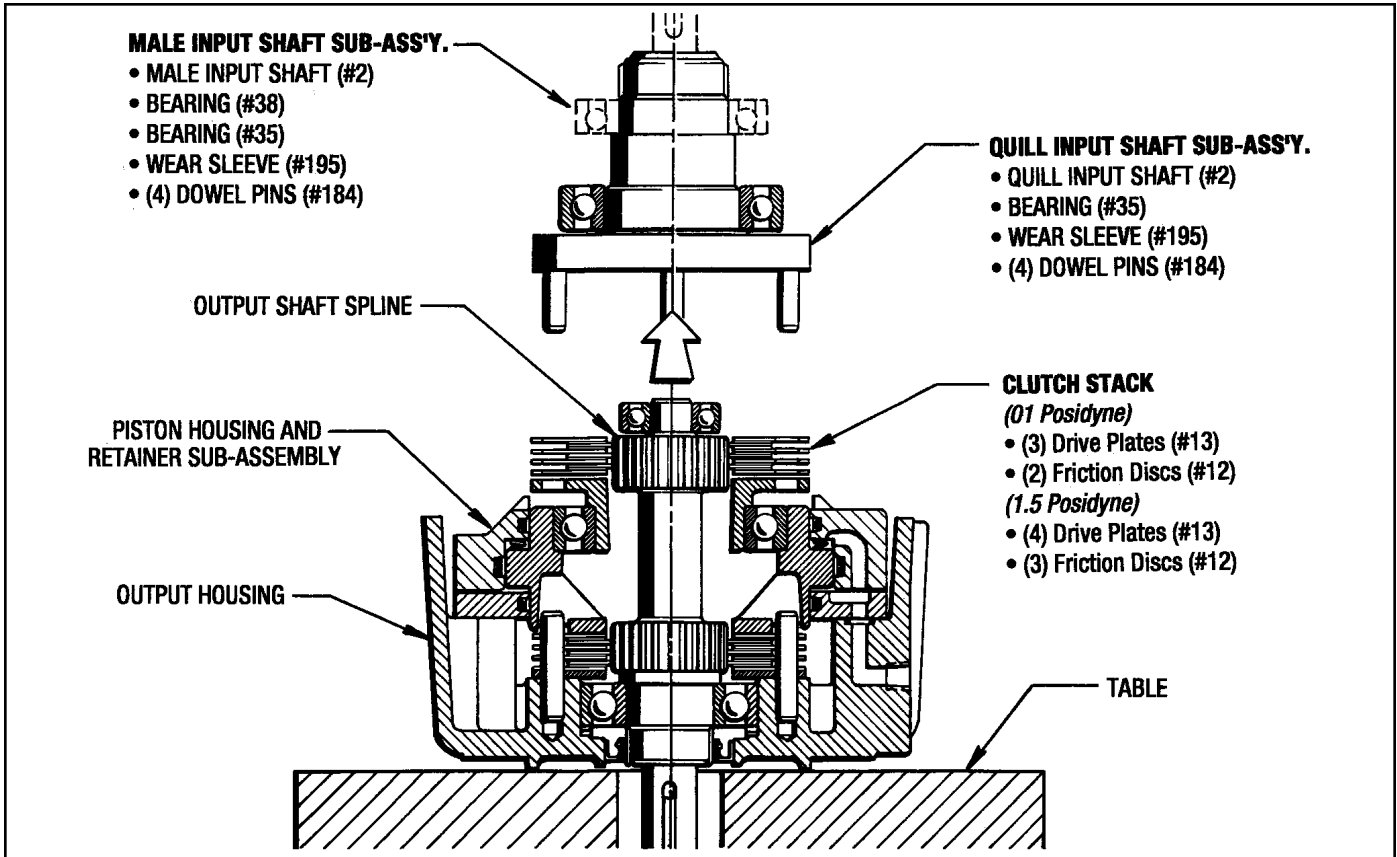

Figure 7.2 - Access to the Clutch Stack

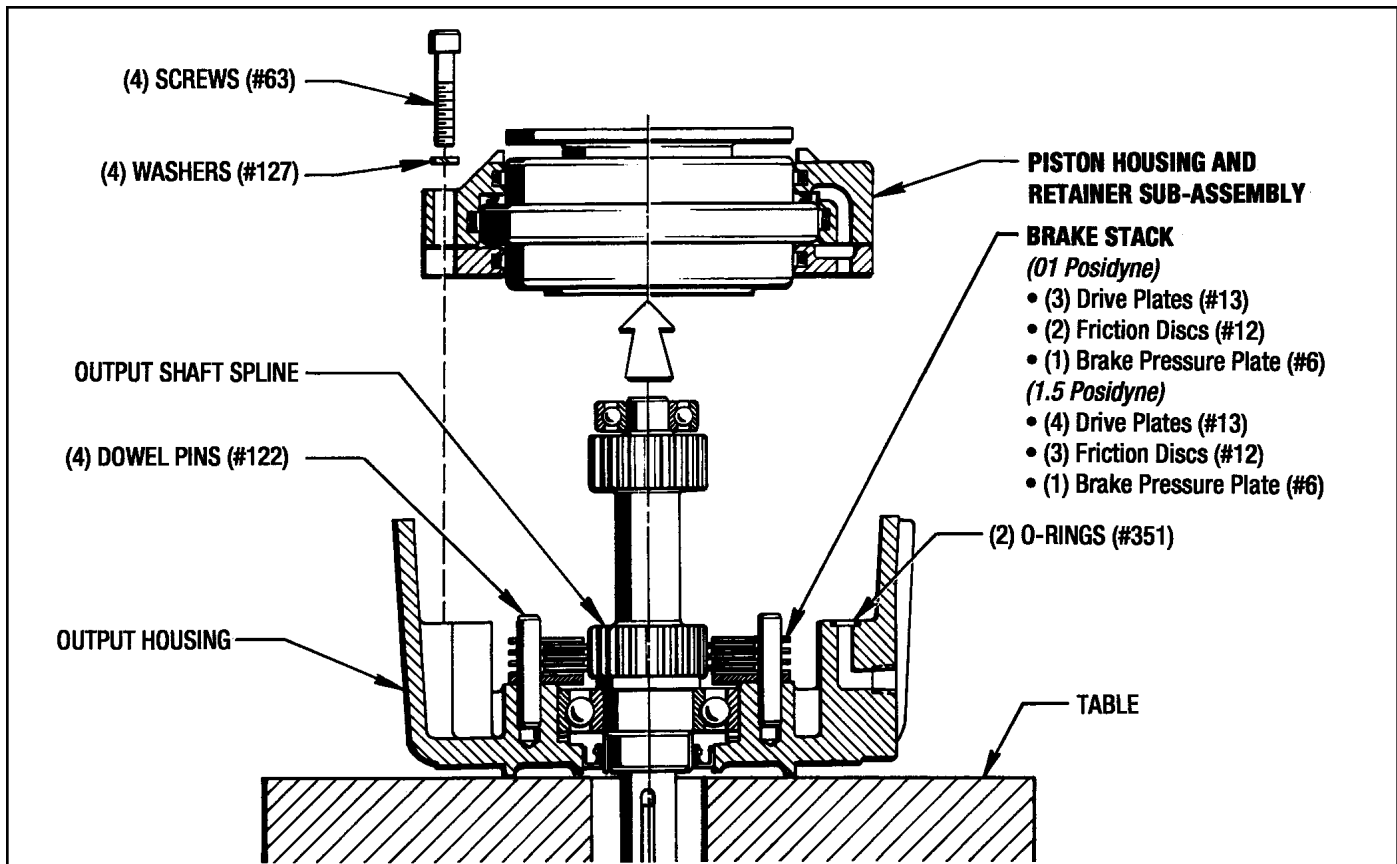

Figure 7.3 - Access to the Brake Stack

(1.5 Posidyne)

1. Remove the (4) Screws (#69) and (4) Lockwashers (#127) from the Input Housing (#8).

(01 and 1.5 Posidyne)

2. Pry the housings apart with a couple screw drivers inserted between the cooling ribs.
3. Pull the Input Housing (#8) and Input Shaft (#2) away from the Output Housing. **Be careful not to damage the lip of the Oil Seal (#31) located in the Input Housing bore.**

NOTE: If there is a Cooling Fan or if you have a Split Clamp Quill on your unit the Input Shaft (#2) will stay in the Input Housing (#8) when it is lifted off the output housing. See Section 7-5 if the Cooling Fan (#25) has to be removed from the Input Shaft (#2).

4. Remove and discard Gasket (#53).
5. Pull the Input Shaft (#2) off the Output Shaft (#1). *At this time this only applies to units with a Key Type Quill.*
6. The Clutch Stack can now be removed from the Output shaft spline. This includes Drive Plates (#13) and Friction discs (#12) (See Figure 7.2)
7. Remove (4) Screws (#63) and (4) Lockwashers (#127) from the Piston Housing Assembly. Pull the Piston Housing Sub-assembly out of the Output Housing and over the end of the Output Shaft (#1).

NOTE: The (2) small O-Rings (#351), located in the inner surface of the Output Housing (#9) can also be removed and checked for damage and replacement now.

8. The Brake Stack can now be removed from the Output Shaft spline. This includes Drive Plates (#13), Friction discs (#12) and a Pressure Plate (#6). (See Figure 7.3)

IMPORTANT NOTE: When removing the Clutch and Brake Stacks, always keep them in the same order as they were removed.

7-5 REMOVING COOLING FAN (#25) FROM THE INPUT SHAFT (#2)

(See Figure 10.6)

1. Place the Input Housing Sub-Assembly into an arbor press and push the Input Shaft (#2) out of the Input Housing (#8). The Cooling Fan (#25) will be pushed off the Input Shaft (#2).
2. Remove and inspect the Tolerance Ring (#251). If it is damaged then replace it with a new one. If it is okay then save it for reassembly.

7-6 QUILL INPUT SHAFT REMOVAL

IMPORTANT: Only remove this Input Shaft if the Bearing (#35) and/or the Wear Sleeve (#195) are damaged and need replaced.

A. With Split Clamp Quill Input Shaft

(See Figure 10.1)

1. Pull the Locking Collar (#281) off the Split Quill Input shaft (#2), if it is still on there.

2. With a pair of pliers squeeze the tangs of the Bearing Retainer (#47) together and remove it.
3. Push the Input Shaft (#2) down and out of the Input Housing (#8) with an arbor press.

B. With Key Type Quill Input Shaft

(See Figure 10.2)

1. Push the Input Shaft (#2) down and out of the Input Housing (#8) with an arbor press.

7-7 QUILL INPUT SHAFT DISASSEMBLY

(See Figures 7.6 and 10.1 and 10.2)

IMPORTANT: Only remove the Bearing (#35) and the Wear Sleeve (#195) if they are damaged and need replaced.

1. With an Arbor Press and a Bearing Splitter, remove Bearing (#35) from the Input Shaft (#2). (See Figure 7.4)

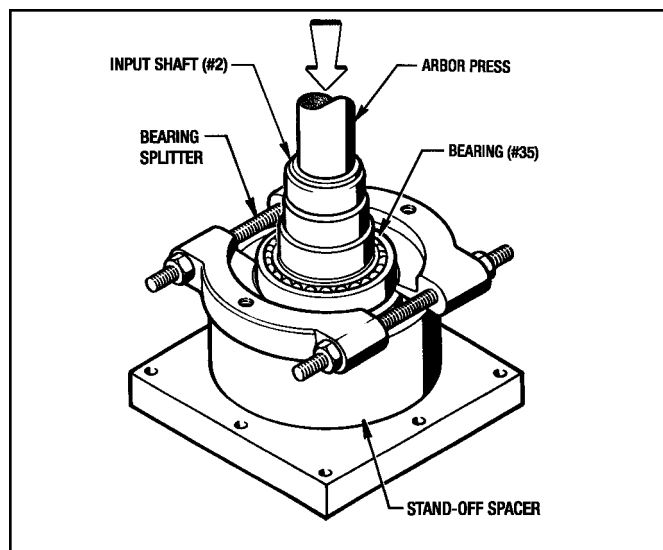

Figure 7.4 - Removing Bearing (#35) from Quill Input Shaft

2. Remove the Wear Sleeve (#195) from the Input Shaft. The procedure is the same as the one shown in Figure 7.6 for the Wear Sleeve (#236) on the output shaft of the 1.5 Posidyne.

The procedure is as follows:

- a. Make 5 or 6 notches in the Wear Sleeve (#195) with a chisel the same width as the Wear Sleeve.
- b. The Wear Sleeve (#195) can now be removed from the Input Shaft by hand.

7-8 MALE INPUT SHAFT DISASSEMBLY

(See Figures 7.7 and 10.3)

IMPORTANT: Only remove Bearings (#35 and #38) and the Wear Sleeve (#195) if they are damaged and need replaced.

1. With an Arbor Press, Bearing Splitter and appropriate tooling first remove Bearing (#38) and then Bearing (#35) from the Input Shaft (#2). (See Figure 7.7 on the next page.)
2. Remove the Wear Sleeve (#195) from the Input Shaft. The procedure is the same as the one shown in Figure 7.6 for the other Wear Sleeve (#236) on the 1.5 Posidyne.

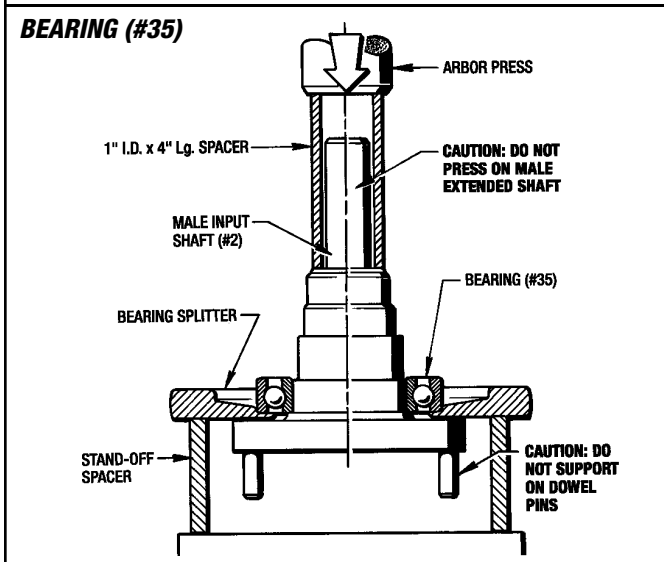
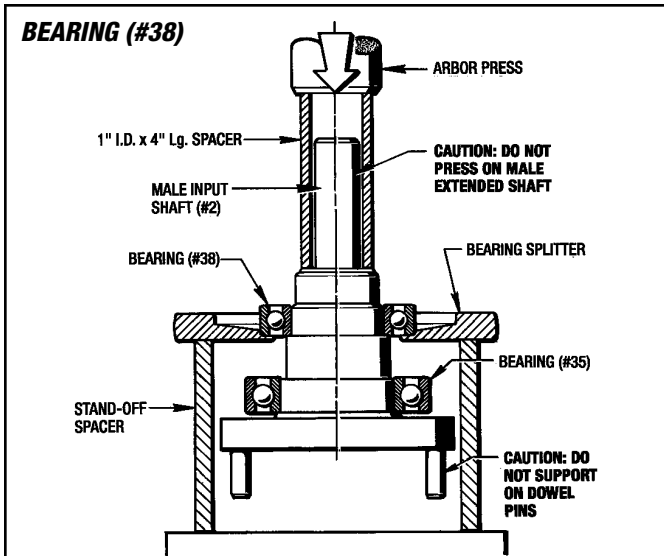

Figure 7.5 - Removing Bearings from Male Input Shaft

7-9 OUTPUT SHAFT REMOVAL AND DISASSEMBLY

A. With Split Clamp Quill Input Shaft

(See Figure 10.1)

1. Remove the Bearing Retainer (#44) from the Output Housing (#9).
2. Tap the Output Shaft (#1) out of the rear of the Output Housing (#9) with a wooden mallet. **Be careful not to damage the lip of the Oil Seal (#32).**

IMPORTANT: Only remove the Bearings (#26 and #28) and the Wear Sleeve (#236) if they are damaged and need replaced.

(1.5 Posidyne Only)

3. Remove the Wear Sleeve (#236) from the Output Shaft as shown in Figure 7.6.

The procedure is as follows:

- a. Make 5 or 6 notches in the Wear Sleeve (#236) with a chisel the same width as the Wear Sleeve.
- b. The Wear Sleeve (#236) can now be removed from the Output Shaft by hand.

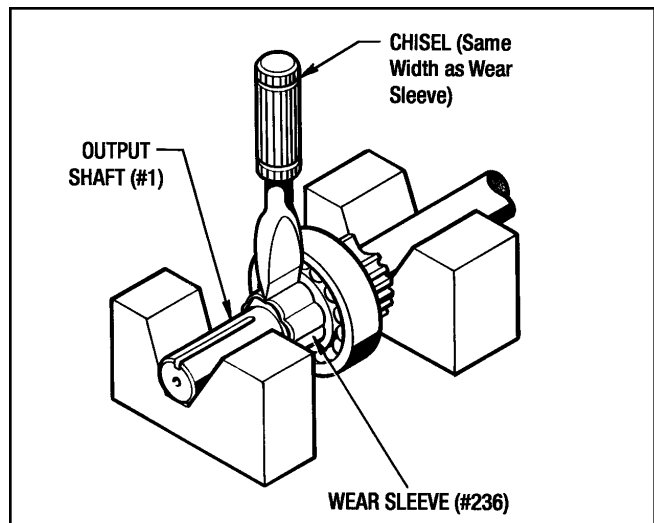

Figure 7.6 - Removing Wear Sleeve (#236) on 1.5 Posidyne (01 and 1.5 Posidyne)

4. Remove Bearing (#26) with a Bearing Puller. (See Figure 7.7)

NOTE: On the 01 Posidyne the Mating Ring (#4) will be pulled off with the Bearing (#26). There is also an O-Ring (#80) behind the 01 Posidyne Mating Ring (#4). Remove it from the Output Shaft (#1).

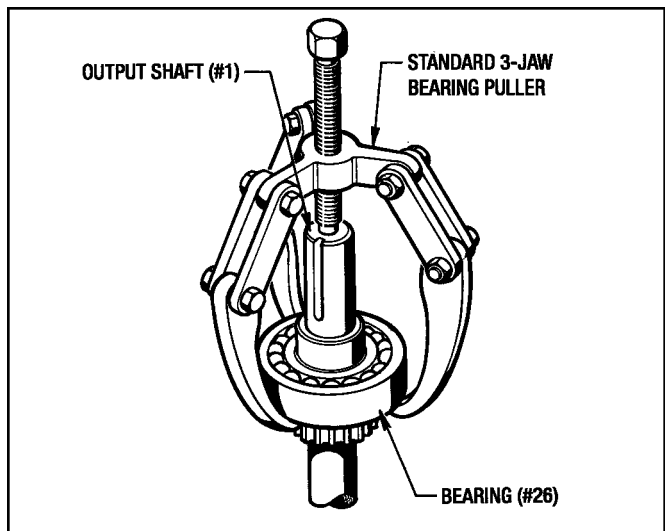

Figure 7.7 - Removing Bearing (#25)

5. If the Pilot Bearing (#28) on the other end of the Output Shaft (#1) needs replaced, take the Screw (#151) or (#76) and the Bearing Retainer Washer (#182) off.
6. Pull the Bearing (#28) off the Output Shaft (#1) with a bearing splitter.

B. With Key Type Quill Input Shaft

(See Figure 10.2)

1. Tap the Output Shaft (#1) out of the rear of the Output Housing (#9) with a wooden mallet. Be careful not to damage the lip of the Oil Seal (#32).
2. Take the Pre-Load Spring (#96) out of the Output Housing bore.

IMPORTANT: Only remove the Bearings (#26 and #28) and the Wear Sleeve (#236) if they are damaged and need replaced.

(1.5 Posidyne Only)

3. Remove the Wear Sleeve (#236) from the Output Shaft with the same procedure as shown in *Figure 7.6*.

The procedure is as follows:

- a. Make 5 or 6 notches in the Wear Sleeve (#236) with a chisel the same width as the Wear Sleeve.
- b. The Wear Sleeve (#236) can now be removed from the Output Shaft by hand.

(01 and 1.5 Posidyne)

4. Remove Bearing (#26) with a Bearing Puller. (See *Figure 7.7*)

NOTE: On the 01 *Posidyne* the Mating Ring (#4) will be pulled off with the Bearing (#26). There is also an O-Ring (#80) behind the 01 *Posidyne* Mating Ring (#4). Remove it from the Output Shaft (#1).

5. Remove the Pilot Bearing (#28), on the other end of the Output Shaft, if it needs replaced.

7-10 REMOVING OIL SEALS

(See *Figures 10.1 or 10.2*)

There is an Oil Seal (#31) in the Input Housing and an Oil Seal (#32) in the Output Housing. **Only remove them if they are damaged and need replaced.**

1. Both Oil Seals can be removed with an Arbor Press.

7-11 PISTON HOUSING SUB-ASSEMBLY DISASSEMBLY

(See *Figure 10.3*)

1. Evenly back out the (4) Screws (#198) and with a screw driver, pry the housings apart. Continue this procedure until the spring pressure is relieved and the housings are separated. Remove the (4) Screws (#198) and (4) Lockwashers (#128).

CAUTION: This Piston Housing Sub-assembly is under spring pressure and care must be taken to avoid personal injury when removing these screws.

2. Remove and discard Gasket (#51).
3. Pull the Piston Sub-Assembly out of the Piston Housing (#10) and remove the Springs (#36) from the Piston (#3).

NOTE: If all of the holes are not used it would be helpful for you to make a free hand sketch of the Spring Placement in the Piston. This will help you at Reassembly.

4. Remove and inspect the O-Rings (#39 and #40) and the Piston Seals (#42 and #43) from the Piston Housing (#10) and the Piston Retainer (#11). (See *Figure 10.2*.)

IMPORTANT: Only remove the Thrust Plate (#5) and the Bearing (#27) from the Piston if they are damaged and need to be replaced.

5. Press out the Thrust Plate (#5) and the Bearing (#27) out of the Piston (#3) with an Arbor Press.
6. With a Bearing Splitter, take the Bearing (#27) off of the Thrust Plate (#5).

This completes the Disassembly Procedure.

Section 8

CLEANING AND INSPECTION

8-1 CLEANING AND INSPECTION

Clean metal parts in a suitable solvent and dry in a stream of low pressure compressed air. The Clutch and Brake Drive Plates (#13) can be cleaned in a solvent, but DO NOT clean the Clutch and Brake Friction Discs (#12) in solvent. Use only a clean, dry and lint-free rag to clean these Friction Discs. (Solvent will damage the resilient paper-based friction material used on the Friction Discs). Keep the Drive Plates and Friction Discs in the same order as they were removed. After cleaning, inspect parts for cracks, distortion, scoring, nicks, burrs or other damage would affect serviceability. Pay particular attention to the following:

1. Check the disc wear surfaces for scoring, galling or evidence of uneven wear.
2. Check the clutch and brake plates for scoring or galling. Make sure they are flat. If a perceptible ridge is worn in any of the drive plates, replace all of the drive plates and friction discs as a complete set.
3. Carefully check the piston and bore surfaces for nicks, scratches, scoring or other damage which would affect operation or cause leakage.

4. Pay particular attention to Wear Sleeves (#195 and #236) and shafts in the area of rotary seals. Check for nicks, scratches which would cause leakage. Replace any damaged parts.
5. It is not necessary to remove the ball bearings to check their operation. Slowly rotate the free race of each bearing by hand checking to see if it turns freely without rough or flat spots.

8-2 REPAIR AND REPLACEMENT

A fine stone or crocus cloth may be used to remove minor surface defects from parts so long as the operating or sealing action of the part is not affected. The use of coarser abrasives or other machining methods should not be attempted. Otherwise, damaged parts should be replaced.

Replacement is recommended also for the following, as applicable:

1. Replace all O-Rings, Liners, Gaskets and Oil Seals removed during the course of disassembly.
2. Replace Clutch or Brake Discs and Drive Plates in complete sets only.

Section 9

REASSEMBLY

9-1 GENERAL REASSEMBLY INSTRUCTIONS

1. Lubricate O-Rings and the lips of Oil Seals with the same oil as used in the Drive Unit immediately before reassembly and installation of any mating parts.
2. The installation of press fitted parts can be eased by heating the outside parts in an oven. Heat bearings to a maximum of 250° F.

CAUTION: Wear suitable gloves when handling heated parts.

3. Apply Gasket Sealant (Permatex #30), or equivalent, only to the flat gasket (#51) between the Piston Housing and the Piston Retainer.
4. Use Cap Screw Adhesive (Loctite #271), or equivalent, to all Cap Screws. Use sparingly and clean off any excess with (Loctite #755) Adhesive Cleaner.

Basically the Reassembly Procedure is just a reverse order of the Disassembly Procedure described in Section 7.

It requires special Assembly Tools to install the Bearings and Wear Sleeves on the Input and Output Shafts. At the end of Section 10 are machining drawings for each Assembly Tool if you prefer to make your own tools. **Each Assembly Tool has a Part Number and can be ordered from the Force Control Factory.**

They are as follows:

(Size 01 Posidyne)

- A. 5/8" Dia. Quill Input Shaft -
Wear Sleeve (#195).....(Part No. 601-01-008)
- B. 7/8" Dia. Quill Input Shaft -
Wear Sleeve (#195).....(Part No. 601-01-009)
- C. 5/8" Dia. Split Quill Input Shaft -
Wear Sleeve (#195).....(Part No. 601-01-013)
- D. 7/8" Dia. Male Input Shaft -
Wear Sleeve (#195).....(Part No. 601-01-005)
- E. 7/8" Dia. Male Input Shaft -
Outboard Bearing (#38).....(Part No. 601-01-006)
- F. 7/8" Dia. Male Input Shaft -
Inboard Bearing (#35).....(Part No. 601-01-010)
- G. Quill Input Shaft -
Inboard Bearing (#35)..... (Part No. 601-01-003)
- H. 5/8" Dia. Output Shaft -
Mating Ring (#4) and Brg. (#26).....(Part No. 601-01-002)
- I. 7/8" Dia. Output Shaft -
Mating Ring (#4) and Brg. (#26).....(Part No. 601-01-007)

(Size 1.5 Posidyne)

- J. 5/8" Dia. Quill Input Shaft -
Wear Sleeve (#195).....(Part No. 601-1.5-006)
- K. 7/8" Dia. Quill Input Shaft -
Wear Sleeve (#195).....(Part No. 601-1.5-001)

- L. 1-1/8" Dia. Quill Input Shaft -
Wear Sleeve (#195).....(Part No. 601-1.5-011)
- M. 5/8" & 7/8" Split Quill Input Shaft -
Bearing (#35) & Wear Sleeve (#195)...(Part No. 601-1.5-017)
- N. 7/8" Dia. Male Input Shaft -
Wear Sleeve (#195).....(Part No. 601-1.5-009)
- O. 7/8" Dia. Male Input Shaft -
Outboard Bearing (#38).....(Part No. 601-1.5-013)
- P. Quill Input Shaft -
Inboard Bearing (#35).....(Part No. 601-1.5-003)
- Q. 7/8" Dia. Male Input Shaft -
Inboard Bearing (#35).....(Part No. 601-1.5-012)
- R. 5/8" Dia. Output Shaft -
Wear Sleeve (#236) & Brg. (#26)....(Part No. 601-1.5-014)
- S. 7/8" Dia. Output Shaft -
Wear Sleeve (#236) & Brg. (#26)....(Part No. 601-1.5-002)
- T. 1-1/8" Dia. Output Shaft -
Wear Sleeve (#236) & Brg. (#26)....(Part No. 601-1.5-015)
- U. 24 mm Dia. Output Shaft -
Wear Sleeve (#236) & Brg. (#26)....(Part No. 601-1.5-022)

9-2 REASSEMBLY OF THE PISTON HOUSING SUB-ASSEMBLY

(See Figure 10.2)

1. Apply Sealant (Loctite #620), or equivalent, to the I.D. of Bearing (#27) and press it onto the Thrust Plate (#5) with an arbor press. **Make sure that the Bearing is well seated on the Thrust Plate shoulder.**

IMPORTANT: Before applying (Loctite #620) to the I.D. and O.D. of Bearing (#27), clean it well with (Loctite #755) Cleaning Solvent.

2. Apply Sealant (Loctite #620) to the O.D. of Bearing (#27) and press the Bearing and Thrust Plate into the Piston (#3). **Make sure that the Bearing is well seated into the piston counterbore.**
3. Install the O-Rings (#39 and #40) and the Teflon Liners (#42 and #43) into the Piston Housing (#10) and Piston Retainer (#11). See Figure 10.2 for correct placement of the Liners and O-Rings.
4. Place the Piston Springs (#36) into the piston holes. White grease may be used to hold the Springs in place during reassembly. Refer to the sketch made at disassembly for correct placement of the Piston Springs.
5. Insert the Piston Sub-Assembly into the Piston Housing (#10). **Be careful not to damage the Teflon Liners in the Piston Housing.**
6. Apply Gasket Sealant (Permatex #30) to the mating surfaces on the Piston Housing (#10) and the Piston Retainer (#11). Install Gasket (#51), using the Dowel Pins (#121) for proper alignment.
7. Place the Piston Retainer (#11) over the Piston (#3). **Be careful not to damage the Teflon Liners in the Piston Retainer.** Attach with (4) Screws (#198) and (4) Lockwashers (#128).

IMPORTANT: Tighten these Screws in an even manner to compress the Piston Springs correctly. Torque to 12 Ft. Lbs.

9-3 OUTPUT SHAFT REASSEMBLY

(See Figures 10.1 and 10.2)

(01 Posidyne)

1. With an arbor press and the proper Assembly Tool, press on the Bearing (#26). Install the O-Ring (#80) onto the Output Shaft shoulder. Then press the Mating Ring (#4) onto the Output Shaft (#1) as shown in Figure 9.1.

(1.5 Posidyne)

1. With an arbor press and the proper Assembly Tool, press the Bearing (#26) and then the Wear Sleeve (#236) onto the Output Shaft (#1) as shown in Figure 9.1.

(01 and 1.5 Posidyne)

2. Next press the Pilot Bearing (#28) onto the other end of the Output Shaft (#1) with an arbor press.

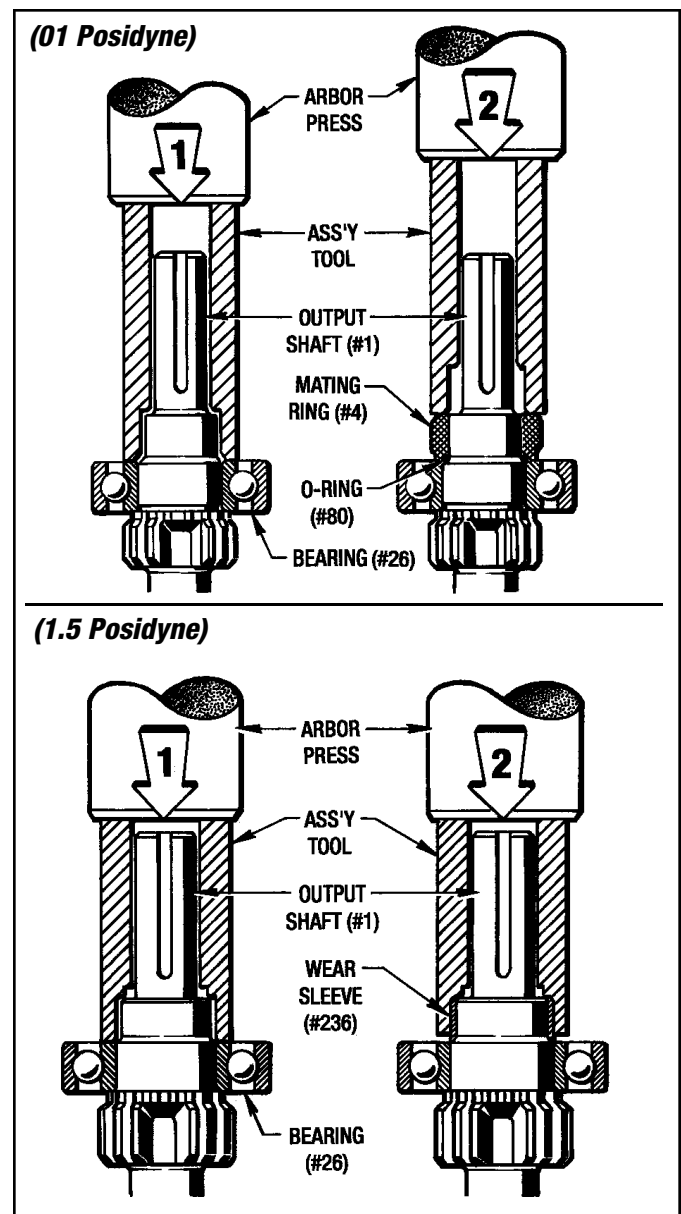

Figure 9.1 - Installing Bearing & Wear Sleeve/Mating Ring

This next Step #3 only applies to units with a Split Clamp Quill Input Shaft. (See Figure 10.1)

(01 Posidyne)

3. Install Screw (#151) and Washer (#182) into the end of the Output Shaft (#1). **Torque to 7 Ft. Lbs.**

(1.5 Posidyne)

3. Install Screw (#76) and Washer (#182) into the end of the Output Shaft (#1). **Torque to 7 Ft. Lbs.**

9-4 INPUT SHAFT REASSEMBLY

(See Figures 10.1 and 10.2)

(Quill Input Shaft)

1. With an arbor press and the appropriate Assembly Tool, install Inboard Bearing (#35) onto the Input Shaft (#2) as shown in Figure 9.2.

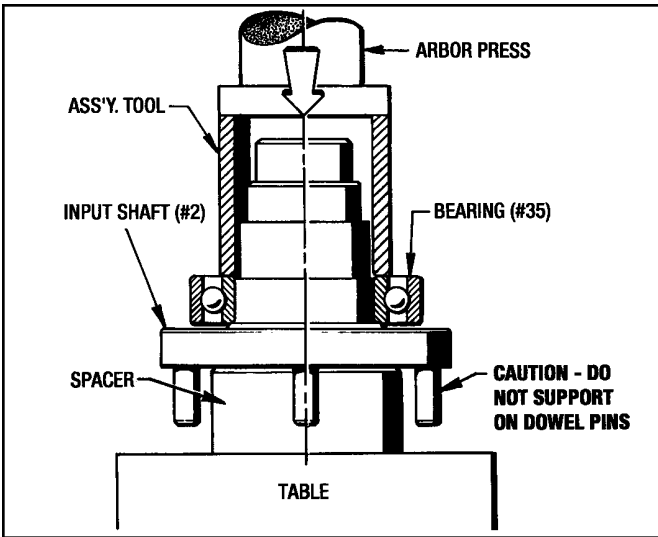

Figure 9.2 - Installing Bearing (#35) on Quill Shaft

2. With an arbor press and the appropriate Assembly Tool, install the Wear Sleeve (#195) onto the Input Shaft (#2) as shown in Figure 9.3.

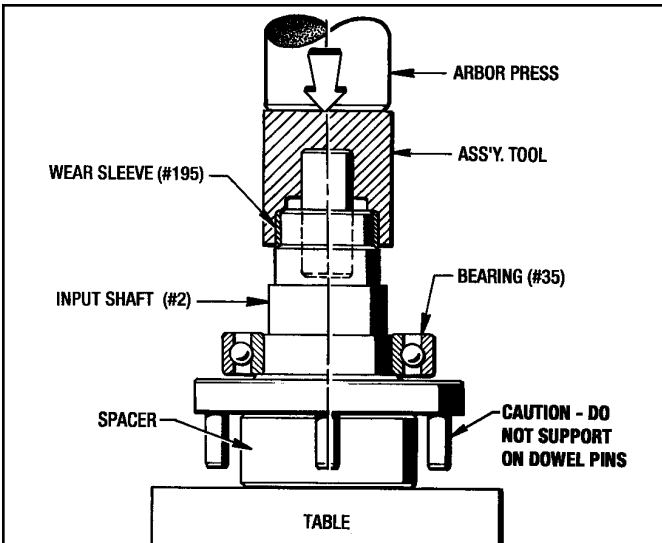

Figure 9.3 - Installing Wear Sleeve (#195) on Quill Shaft

(Male Extended Input Shaft)

1. With an arbor press and the appropriate Assembly Tool, install Inboard Bearing (#35) onto the Input Shaft (#2) as shown in Figure 9.4.

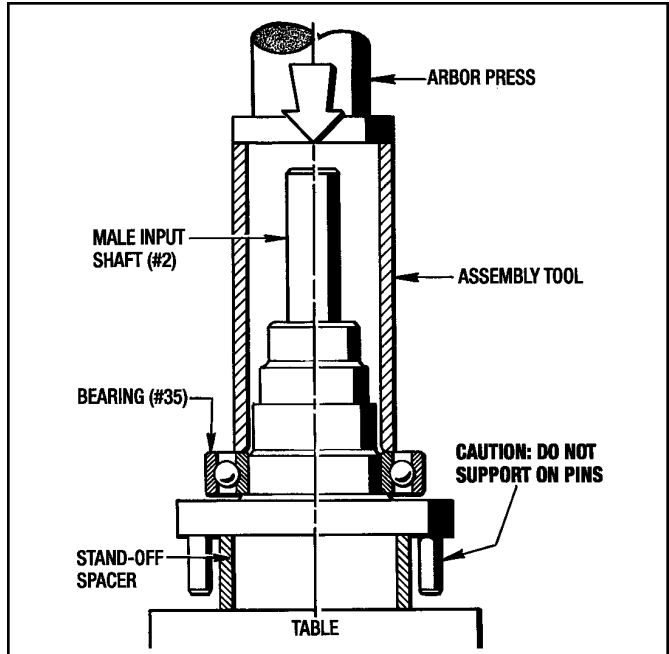

Figure 9.4 - Installing Inboard Bearing (#35) on Male Shaft

2. With an arbor press and the appropriate Assembly Tool, install Outboard Bearing (#38) onto the Input Shaft (#2) as shown in Figure 9.5.

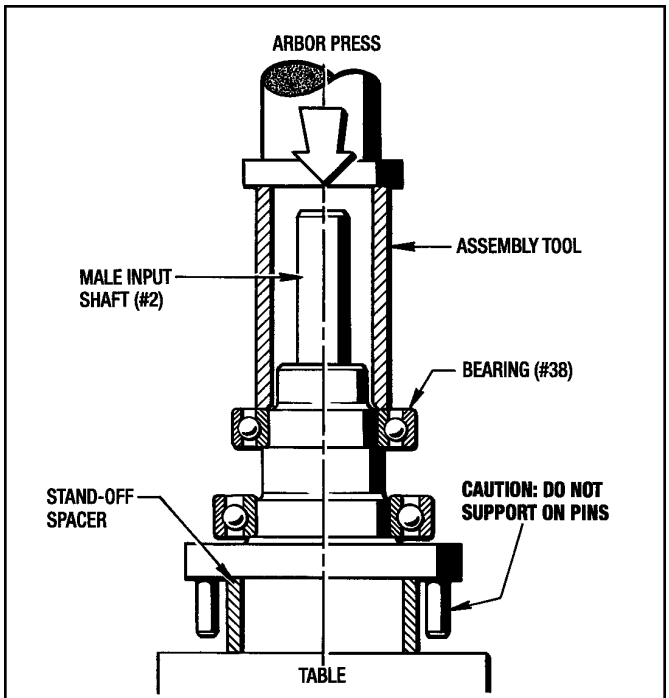

Figure 9.5 - Installing Outboard Bearing (#38) on Male Shaft

3. With an arbor press and the appropriate Assembly Tool, install the Wear Sleeve (#195) onto the Male Input Shaft (#2) as shown in Figure 9.6 on next page.

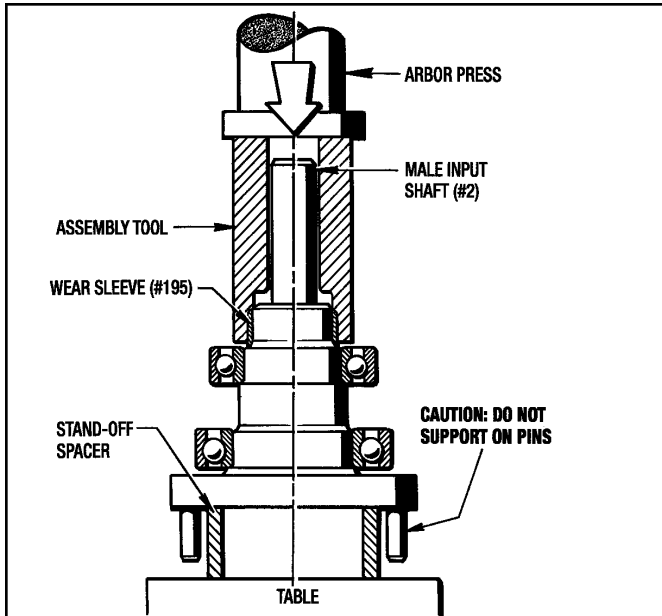

Figure 9.6 - Installing Wear Sleeve (#195) on Male Shaft

9-5 INSTALLING OIL SEALS INTO INPUT AND OUTPUT HOUSINGS

(See Figures 10.1 and 10.2)

1. Press the Oil Seal (#32) into the Output Housing (#9). Use Sealant (Permatex #30) on the outside diameter of the Oil Seal.
2. Press the Oil Seal (#31) into the Input Housing (#8). Use Sealant (Permatex #30) on the outside diameter of the Oil Seal.

9-6 INSTALLING OUTPUT SHAFT INTO THE OUTPUT HOUSING

A. With Split Quill Input Shaft

(See Figure 10.1)

1. First lubricate the lip of the Oil Seal (#32) with vaseline or equivalent.
2. Carefully insert the Output Shaft (#1) into the Output Housing (#9) until the Bearing (#26) is completely seated in the bearing bore.

CAUTION - Be very careful not to damage the lip of the Oil Seal (#32) when inserting the Output Shaft (#1).

3. Squeeze the tangs of the Bearing Retainer (#44) together and install it into the bearing retainer grooves.

B. Without Split Quill Input Shaft

(See Figure 10.2)

1. Place the Pre-Load Spring (#96) into the Output Housing bearing bore.
2. Lubricate the lip of the Oil Seal (#32) with vaseline or equivalent.
3. Carefully insert the Output Shaft (#1) into the Output Housing (#9) until the Bearing (#26) is completely seated in the bearing bore.

CAUTION - Be very careful not to damage the lip of the Oil Seal (#32) when inserting the Output Shaft (#1).

9-7 MEASURING AND CONTROLLING STACK HEIGHT

To assure correct piston travel, the following steps must be done when replacing the Clutch and Brake Stacks.

1. Based on the parts list, place the total number of Friction Discs (#12) and Drive Plates (#13) in an arbor press as shown in Figure 9.7. Clamp firmly and measure the stack height.

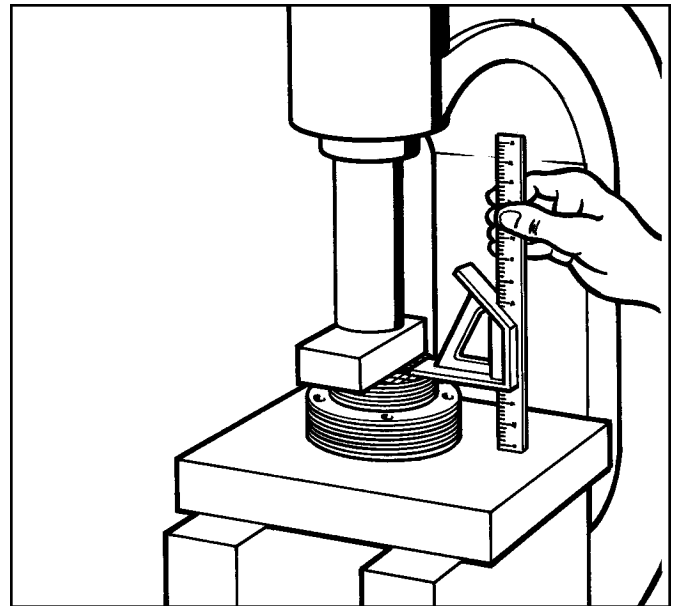

Figure 9.7 - Measuring Stack Height

2. Compare the measurement with the tabulated value given in the following Stack Height Table and, if necessary, add one or two Drive Plates to bring the stack within specified limits.

NOTE: Always add the extra Drive Plate to the stack side away from the Piston. Add 1st. extra plate to the Clutch Stack and 2nd. extra plate to the Brake Stack.

STACK HEIGHT TABLE

SIZE	MIN	MAX
01 with Clutch Only	.365"	.385"
01 with Clutch & Brake	.730"	.770"
01.5 with Clutch Only	.546"	.586"
01.5 with Clutch & Brake	1.092"	1.172"

9-8 INSTALLING BRAKE STACK

(See Figures 9.8 and 10.1)

Place the Output Housing on a flat stable surface with the keyed end of the Output Shaft in a down position.

1. First install the Brake Pressure Plate (#6) Align the holes in the Brake Pressure Plate with the Pins (#122) in the Output Housing.

- Next place the Brake Stack onto the Output Shaft Spline, starting with a Drive Plate (#13) and then a Friction Disc (#12), ending with a Drive Plate (#13). Align the holes in the Drive Plates with the Pins (#122) in the Output Housing and align the internal teeth in the Friction Discs with the teeth on the Output Shaft Spline.

NOTE: See Figure 10.8 for Brake Stack Configuration with Vertical Installation.

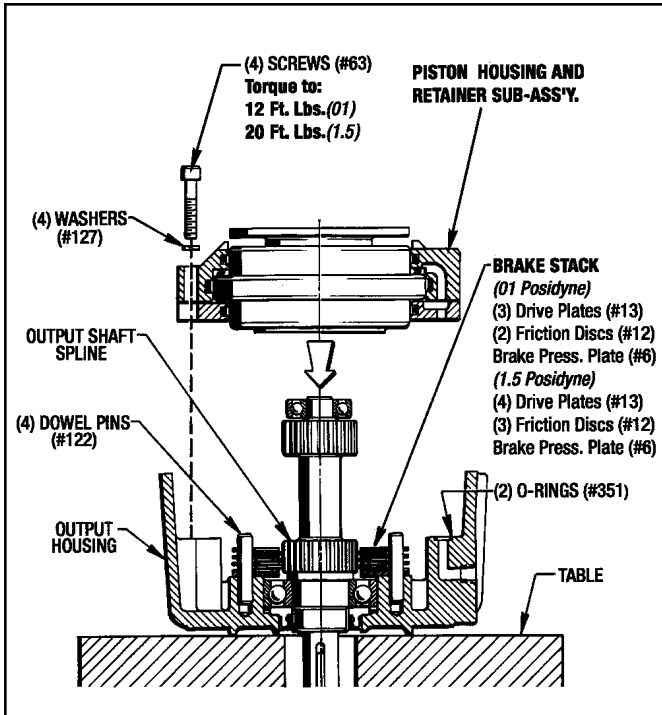

Figure 9.8 - Installing Brake Stack

9-9 INSTALLING THE PISTON HOUSING ASSEMBLY

(See Figure 9.8 and 10.1)

- First place the (2) O-Rings (#351) into the (2) counterbores in the Output Housing. (See Figure 9.8 for location of these O-Rings.)
- Attach the Piston Housing Assembly with (4) Screws (#63) and (4) Lockwashers (#127). (See Figure 9.8 for Torque Requirements.)

9-10 INSTALLING CLUTCH STACK

(See Figures 9.9 and 10.1)

- Place the Clutch Stack onto the Output Shaft Spline, starting with a Drive Plate (#13) and then a Friction Disc (#12), ending with a Drive Plate (#13). Center the Drive Plates (#13) on the Output Shaft as close as possible and align all the holes up in the Drive Plates. Align the internal teeth in the Friction Discs (#12) with the teeth on the Output Shaft Spline.

NOTE: See Figure 10.8 for Clutch Stack Configuration with Vertical Installation.

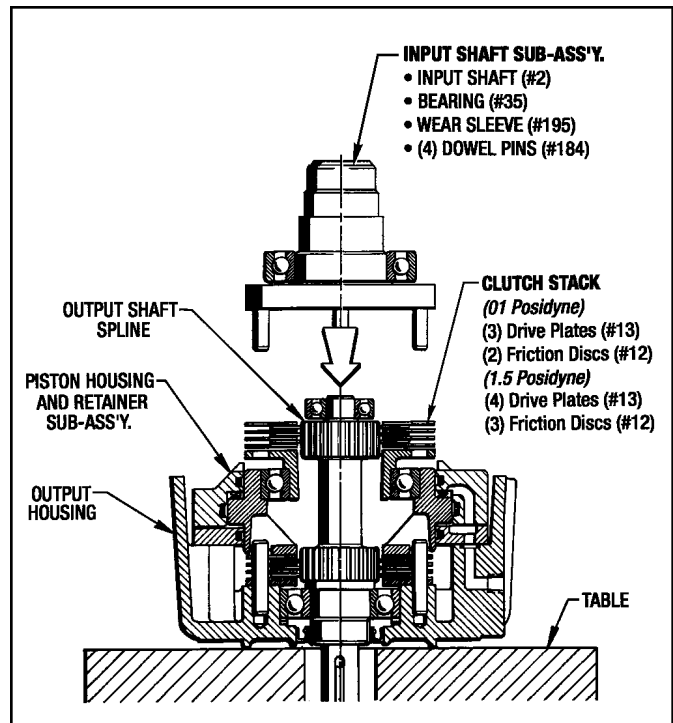

Figure 9.9 - Installing Clutch Stack

9-11 INSTALLING INPUT SHAFT AND INPUT HOUSING

A. With Split Quill Input Shaft

(See Figure 10.1)

- Lubricate the lip of the Oil Seal (#31) with vaseline or equivalent.
- Carefully insert the Input Shaft (#2) into the Input Housing (#8) until the Bearing (#35) is completely seated in the bearing bore.

CAUTION - Be very careful not to damage the lip of the Oil Seal (#31) when inserting the Input shaft (#2).

- Squeeze the tangs of the Bearing Retainer (#47) together and install it into the bearing retainer grooves.
- Place the Gasket (#53) onto the Output Housing (#9) face. Use the (2) Dowel Pins (#121) to align the gasket properly.
- Make sure that the holes in the Clutch Stack Drive Plates (#13) are all aligned with each other.
- Place the Input Housing (#8) and Input Shaft (#2) down on the Output Housing (#9) and clutch stack. **Make sure the (4) Driver Pins (#184) in the Input Shaft (#2) are aligned with the holes in the clutch stack.** Tap the Input Housing (#8) and the Input Shaft (#2) until they are firmly seated On the Pilot Bearing (#28) and the Output Housing (#9) face.
- Attach the housings together with (4) Screws (#69) and (4) Lockwashers (#127). (See Figure 10.1 for Torque Requirements.)

NOTE: The Unit will have to be turned over for the 01 *Posidyne* to insert the screws and lockwashers

- Loosely install the Locking Collar (#281) on the Split Quill Input shaft (#2). Do not tighten at this time. Make sure the roll pin in the collar fits in the drilled indent in the shaft.

B. Without Split Quill Input Shaft

(See Figure 10.2)

- Aligning the Pins (#184) in the Input Shaft (#2) up with the holes in the Drive Plates (#13), place the Input Shaft onto the Clutch Stack and the Output Shaft Pilot Bearing (#28). Tap the Input Shaft until it seats on the Pilot Bearing.
- Position the Gasket (#53) onto the Output Housing. Use the Dowel Pins (#121) in the housing face to align up the gasket.
- Lubricate the lip of the Oil Seal (#31) with vaseline or equivalent.
- Carefully place the Input Housing (#8) over the Input Shaft until the Inboard Bearing (#35) is seated firmly into the bearing bore and the Input Housing is resting firmly onto the Output Housing. Use the Dowel Pins (#121) to align the housings. **Be very careful that you don't damage the lip of Oil Seal (#31) in the Input Housing.**
- Attach the housings together with (4) Screws (#69) and (4) Lockwashers (#127). (See Figure 10.1 for Torque Requirements.)

NOTE: The Unit will have to be turned over for the 01 *Posidyne* to insert the screws and lockwashers.

9-12 INSTALLING COOLING FAN ON INPUT SHAFT

(See Figure 10.6)

(Quill Input Shaft)

- Place the Tolerance Ring (#251) into the Fan (#25) and press them both onto the Input Shaft (#2).

(Male Input Shaft)

- First place the Tolerance Ring (#251) onto the Male Input Shaft (#2), then press the Fan (#25) onto the Input Shaft (#2) and Tolerance Ring (#251) as far as it will go.

9-13 FINAL REASSEMBLY

- Replace any Pipe Plugs, Air Breather, Sight Gauge, etc. removed during disassembly.
- Fill with Automatic Transmission Fluid as specified in **Section 4 LUBRICATION.**

This completes the Reassembly Procedure for the 01 and 1.5 *Posidyne* Clutch/Brake Unit. Before proceeding any further an Operational Check of the Clutch and Brake movement should be made. Apply 60 to 80 PSI to the Clutch and Brake ports, as indicated in **Section 5 - OPERATIONAL CHECKS**, and observe the Piston Movement through the inspection port.

- Replace any optional equipment removed during disassembly such as:
 - 8-1/2" AK C-Face Flanges (See Figure 10.4)
 - Manifold Mounted Control Valve (See Figure 10.5)
 - Optical Encoder Assembly (See Figure 10.5)
 - Fan Cooling (See Figure 10.6 and Section 9-12 above.)
 - Foot Mounting (See Figure 10.7)
 - Vertical Installation (See Figure 10.9)

9-14 REMOUNTING THE DRIVE

UNIT TO THE C-FACE MOTOR

(See Figure 3.1 in Section 3 INSTALLATION)

Refer to **3-2 Mounting the Drive Unit** for correct Mounting Spool Alignment procedure.

After Reassembly is completed completely check the operation of your *Posidyne* Clutch/Brake as specified in Section 5 - OPERATIONAL CHECKS.

Section 10

ORDERING REPAIR PARTS

10-1 GENERAL INFORMATION

This section illustrates, lists and describes all available repair parts for the Force Control 01 and 1.5 Posidyne Clutch/Brake Drive Units. Parts are identified on the exploded views with Part Reference Numbers. These Numbers correspond to the Part Reference Number given in the Parts List. The Part Name and Quantity is also given in the Parts List. This Part Reference Number, Part Name and Quantity should be used when ordering parts.

The Exploded View Drawings are as follows:

- Figure 10.1 - 01 and 1.5 Posidyne Clutch Brake Unit.
- Figure 10.2 - Piston Housing and Retainer Sub-Assembly.
- Figure 10.3 - Optional Extended Male Input Shaft. Optional 8-1/2" AK C-Face Adapters.
- Figure 10.4 - Optional Manifold Mounted Control Valves. Optional Positioning Encoder Assembly.
- Figure 10.5 - Optional Foot Mounting (With C-Face Motor)
- Figure 10.6 - Optional Fan Cooling. Optional Foot Mounting.
- Figure 10.7 - Clutch/Brake Stacks (Vertical Mounting)
- Figure 10.8 - Vertical Installation Kits.

10-2 DRIVE MOTORS

The motors used with these Drive Units are standard and may be repaired or replaced by any qualified motor rebuild facility or supplier.

10-3 FACTORY REBUILD SERVICE

Reconditioning service is offered by Force Control Industries at the factory. Unless major parts (such as housings and pistons, etc.) are damaged, the cost of complete factory rebuild will be 50% the cost of a new unit. Before returning a unit for this service, however, be sure to first contact the Force Control Industries Service Sales Department for authorization and shipping instructions. Force Control Industries cannot be responsible for units returned to the factory without prior notice and authorization.

Care must be given to the packing of return drives. Always protect mounting feet by attaching to a skid. Shipment-damaged drives always delay repairs. It is usually impossible to recover damage costs from the carrier. When possible describe the problem experienced on your shipping papers.

RETURN TO :

Force Control Industries, Inc.
3660 Dixie Highway
Fairfield, Ohio 45014

Telephone: 513-868-0900
Fax No.: 513-868-2105
E-Mail: info@forcecontrol.com

10-4 ORDERING REPLACEMENT PARTS

When ordering replacement parts, please specify all of the following information:

1. **Drive Model Number** (on the name plate)
2. **Drive Serial Number** (on the name plate)
3. **Part Reference Number** (from the parts list or exploded view drawing.)
4. **Part Name** (from the parts list)
5. **Quantity** (from the parts list)
6. **Complete Shipping Information**

Failure to include information for items 1 thru 6 will only delay your parts order. Unless another method is specified for item 6, parts less than 150 pounds will be shipped United Parcel Service, parts over 150 pounds will be shipped Motor Freight. Air freight and other transportation services are available but only if specified on your order.

10-5 NAME PLATE and MODEL NUMBERS

The Name Plate shown is located on the Input Housing.

Force Control Industries, Inc.	
Fairfield, Ohio	
	For Service/Parts Call
	513-868-0900
Posidyne®	Clutch/Brake
Model No.	<input type="text"/>
Serial No.	<input type="text"/>
Use Mobil® ATF 210	

01 and 1.5 Posidyne Clutch/Brake

MODEL NUMBERS

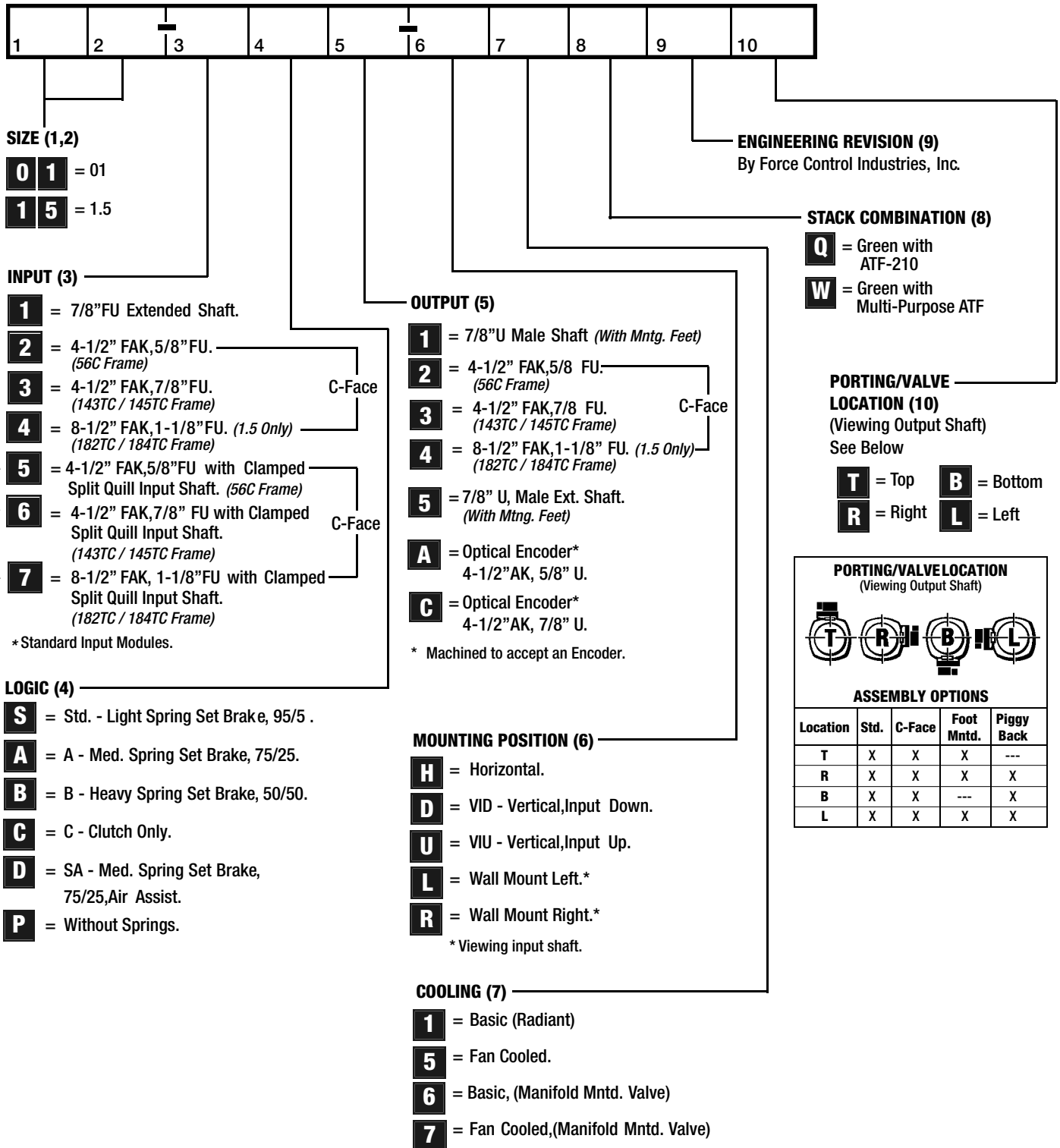

01 and 1.5 Posidyne CLUTCH/BRAKE UNIT
(With Split Clamp Quill Input Shaft)
 (Figure 10.1)

REF. No.	PART NAME	QTY.	REF. No.	PART NAME	QTY.
1	Output Shaft	1	69	Soc. Hd. Cap Screw.....	4
2	Quill Input Shaft.....	1	72	Pipe Plug, 1/2" NPT.....	2
**4	Mating Ring (01 Posidyne only).....	1	73	Reducer Bushing.....	1
*6	Brake Pressure Plate (Not on "C" Logic.)	1	74	Pipe Plug, 1/8" NPT.....	2
8	Input Housing	1	76	Soc. Hd. Cap Screw (1.5 Posidyne only).....	1
9	Output Housing.....	1	*80	O-Ring (01 Posidyne only)	1
*12	Friction Disc (See note below)		121	Dowel Pin, 1/4" x 1".....	2
	01 - "A", "B", "S", and "SA" Logic.....	4	122	Dowel Pin, Brake (Not used on "C" Logic)..	4
	01 -"C" Logic.....	2	127	Lockwasher.....	8
	1.5 - "A", "B", "S", and "SA" Logic.....	6	151	Soc. Hd. Cap Screw (01 Posidyne only).....	1
	1.5 -"C" Logic.....	3	154	Soc. Set Screw, Cone Point.....	4
*13	Drive Plate (See note below)		181	Key, Output Shaft	1
	01 -"A", "B", "S", and "SA" Logic.....	6	182	Washer, Bearing Retainer	1
	01 -"C" Logic.....	3	184	Dowel Pin, Clutch.....	4
	1.5 -"A", "B", "S", and "SA" Logic.....	8	*195	Wear Sleeve.....	1
	1.5 -"C" Logic.....	4	208	Plug, Input Shaft.....	1
*26	Bearing, Output Shaft.....	1	218	Roll Pin (01 Posidyne Only)	1
*28	Pilot Bearing.....	1	221	Spool, Mounting (Std. 4-1/2" AK Input)	4
*31	Oil Seal, Input Shaft	1	*236	Wear Sleeve (1.5 Posidyne only).....	1
*32	Oil Seal, Output Shaft.....	1	241	Heli-coil Insert.....	4
*35	Bearing, Input Shaft.....	1	281	Locking Collar.....	1
*44	Bearing Retainer.....	1	303	Roll Pin (1.5 Posidyne Only)	1
**45	Air Breather	1	305	Hex. Hd. Cap Screw.....	4
**46	Sight Gauge.....	1	346	Heli-coil Insert.....	4
*47	Bearing Retainer.....	1	*351	O-Ring	2
*53	Main Gasket	1	367	Lockwasher, 3/8"	4
63	Soc. Hd. Cap Screw.....	4			

* - Indicates parts in Minor Overhaul Kit.

** - Indicates parts in Major Overhaul Kit. (Plus all parts in Minor Overhaul Kit.)

NOTE: See Figure 10.8 for Clutch/Brake Stacks with Vertical Installation.

01 and 1.5 Posidyne CLUTCH/BRAKE UNIT (With Split Clamp Quill Input Shaft)

- * TORQUE REQUIREMENTS:**
SCREW (#63) and (#69)
 01 - 12 Ft. Lbs.
 1.5 - 20 Ft. Lbs.
SCREW (#154)
 01, 1.5 - 12 Ft. Lbs.
SCREW (#305)
 01, 1.5 - 25 Ft. Lbs.
SCREWS (#76) & (#151)
 01, 1.5 - 7 Ft. Lbs.

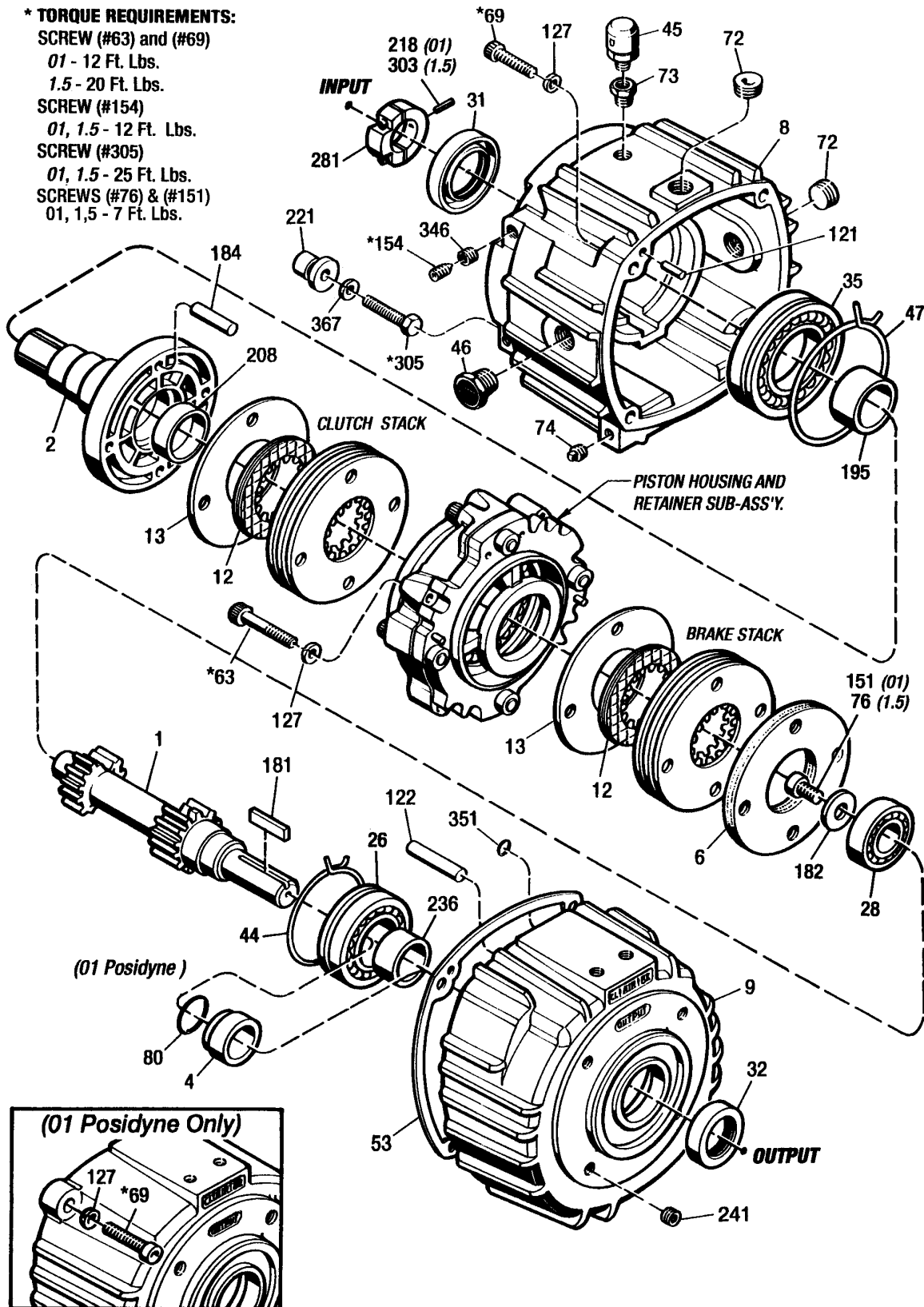

Figure 10.1 - 01 and 1.5 Posidyne Clutch/Brake Unit With Split Quill Input Shaft

01 and 1.5 Posidyne CLUTCH/BRAKE UNIT
(With Key Type Quill Input Shaft)
 (Figure 10.2)

REF. No.	PART NAME	QTY.	REF. No.	PART NAME	QTY.
1	Output Shaft	1	63	Soc. Hd. Cap Screw.....	4
2	Quill Input Shaft.....	1	69	Soc. Hd. Cap Screw.....	4
**4	Mating Ring (01 <i>Posidyne</i> only).....	1	72	Pipe Plug, 1/2" NPT.....	2
*6	Brake Pressure Plate (Not on "C" Logic.) ...	1	73	Reducer Bushing.....	1
8	Input Housing	1	74	Pipe Plug, 1/8" NPT.....	2
9	Output Housing.....	1	*80	O-Ring (01 <i>Posidyne</i> only).....	1
*12	Friction Disc (See note below)		*96	Spring, Bearing Pre-load.....	1
	01 - "A", "B", "S", and "SA" Logic.....	4	121	Dowel Pin, 1/4" x 1".....	2
	01 -"C" Logic.....	2	122	Dowel Pin, Brake (Not used on "C" Logic)..	4
	1.5 - "A", "B", "S", and "SA" Logic.....	6	127	Lockwasher.....	8
	1.5 -"C" Logic.....	3	154	Soc. Set Screw, Cone Point.....	4
*13	Drive Plate (See note below)		180	Key, Input Shaft.....	1
	01 -"A", "B", "S", and "SA" Logic.....	6	181	Key, Output Shaft	1
	01 -"C" Logic.....	3	184	Dowel Pin, Clutch.....	4
	1.5 -"A", "B", "S", and "SA" Logic.....	8	*195	Wear Sleeve.....	1
	1.5 -"C" Logic.....	4	208	Plug, Input Shaft.....	1
*26	Bearing, Output Shaft.....	1	221	Spool, Mounting (Std. 4-1/2" AK Input)	4
*28	Pilot Bearing.....	1	*236	Wear Sleeve (1.5 <i>Posidyne</i> only).....	1
*31	Oil Seal, Input Shaft	1	241	Heli-coil Insert.....	4
*32	Oil Seal, Output Shaft.....	1	305	Hex. Hd. Cap Screw.....	4
*35	Bearing, Input Shaft.....	1	346	Heli-coil Insert.....	4
**45	Air Breather	1	*351	O-Ring	2
**46	Sight Gauge.....	1	367	Lockwasher, 3/8"	4
*53	Main Gasket	1			

* - Indicates parts in Minor Overhaul Kit.

** - Indicates parts in Major Overhaul Kit. (Plus all parts in Minor Overhaul Kit.)

NOTE: See *Figure 10.8* for Clutch/Brake Stacks with Vertical Installation.

01 and 1.5 Posidyne CLUTCH/BRAKE UNIT (With Key Type Quill Input Shaft)

- * TORQUE REQUIREMENTS:**
SCREW (#63) and (#69)
 01 - 12 Ft. Lbs.
 1.5 - 20 Ft. Lbs.
SCREW (#154)
 01, 1.5 - 12 Ft. Lbs.
SCREW (#305)
 01, 1.5 - 25 Ft. Lbs.

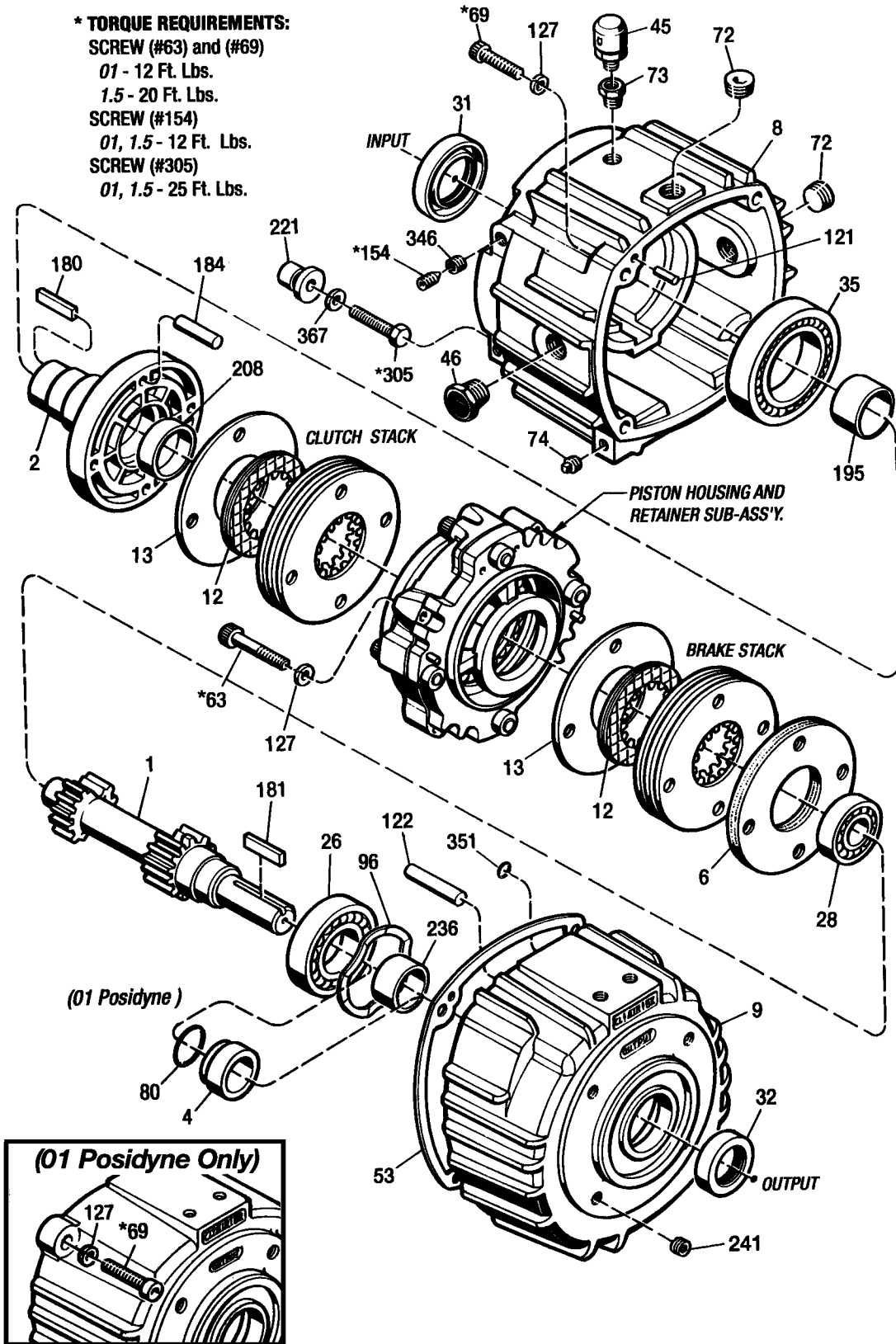

Figure 10.2 - 01 and 1.5 Posidyne Clutch/Brake Unit With Key Type Quill Input Shaft

PISTON HOUSING & RETAINER SUB-ASSEMBLY

(Figure 10.3)

REF. No.	PART NAME	QTY.	REF. No.	PART NAME	QTY.
3	Piston.....	1	* 40	O-Ring	
** 5	Clutch Thrust Plate.....	1		01 <i>Posidyne</i>	2
10	Piston Housing	1		1.5 <i>Posidyne</i>	1
11	Piston Retainer.....	1	* 42	Teflon Liner	
* 27	Bearing	1		"S" and "SA" Logic.....	2
* 36	Compression Spring			"A", "B" and "C" Logic.....	1
	01 <i>Posidyne</i> - "S" and "C" Logic.....	6	* 43	Teflon Liner.....	1
	01 <i>Posidyne</i> - "A" and "SA" Logic.....	14	* 51	Gasket	1
	01 <i>Posidyne</i> - "B" Logic.....	28	121	Dowel Pin	4
	1.5 <i>Posidyne</i> - "S" and "C" Logic.....	6	128	Lockwasher, 5/16"	4
	1.5 <i>Posidyne</i> - "A" and "SA" Logic.....	18	152	Cinch Nut.....	4
	1.5 <i>Posidyne</i> - "B" Logic	36	198	Soc. Hd. Cap Screw.....	4
* 39	O-Ring				
	"S" and "SA" Logic.....	2			
	"A", "B" and "C" Logic.....	1			

* - Indicates parts in Minor Overhaul Kit.

** - Indicates parts in Major Overhaul Kit. (Plus all parts in Minor Overhaul Kit.)

PISTON HOUSING & RETAINER SUB-ASSEMBLY

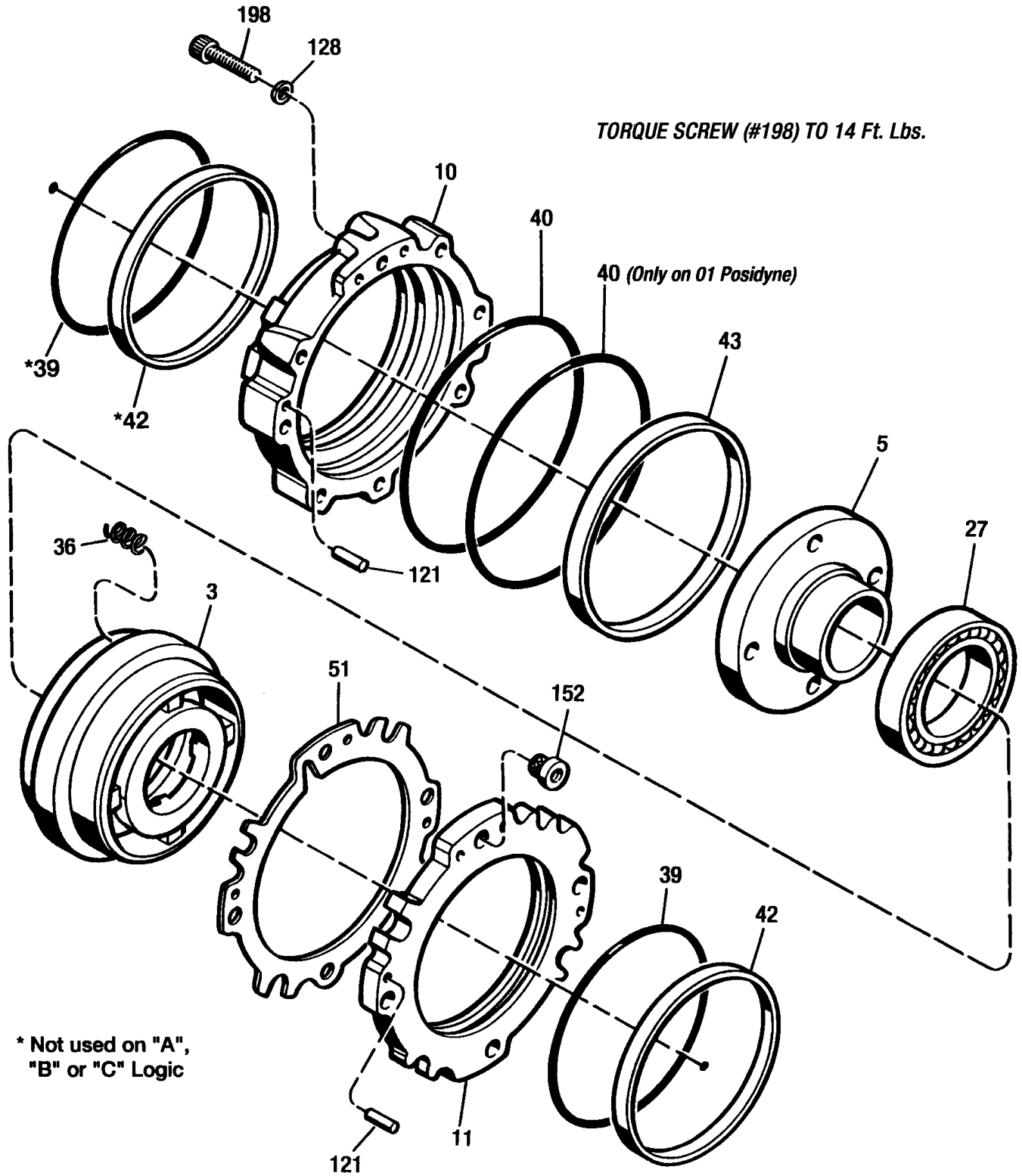

Figure 10.3 - Piston Housing & Retainer Sub-Assembly

OPTIONAL EXTENDED MALE INPUT SHAFT
OPTIONAL 8-1/2" AK C-FACE ADAPTER (1.5 Posidyne Only)
 (Figure 10.4)

REF. No.	PART NAME	QTY.	REF. No.	PART NAME	QTY.
2	Output Shaft	1	201	Soc. Hd. Cap Screw.....	4
*35	Bearing	1	203	Output C-Face Adapter, 8-1/2" AK	1
*38	Bearing	1	204	Soc. Hd. Cap Screw.....	4
154	Set Screw, Cone Point	4	205	Lockwasher.....	4
180	Key.....	1	239	Mounting Spool.....	4
184	Dowel Pin, Clutch.....	4	305	Hex. Hd. Cap Screw.....	4
*195	Wear Sleeve.....	1	367	Lockwasher.....	4
200	Input C-Face Adapter, 8-1/2" AK.....	1	392	Heli-Coil Insert.....	4

* - Indicates parts in Minor Overhaul Kit.

OPTIONAL EXTENDED MALE INPUT SHAFT

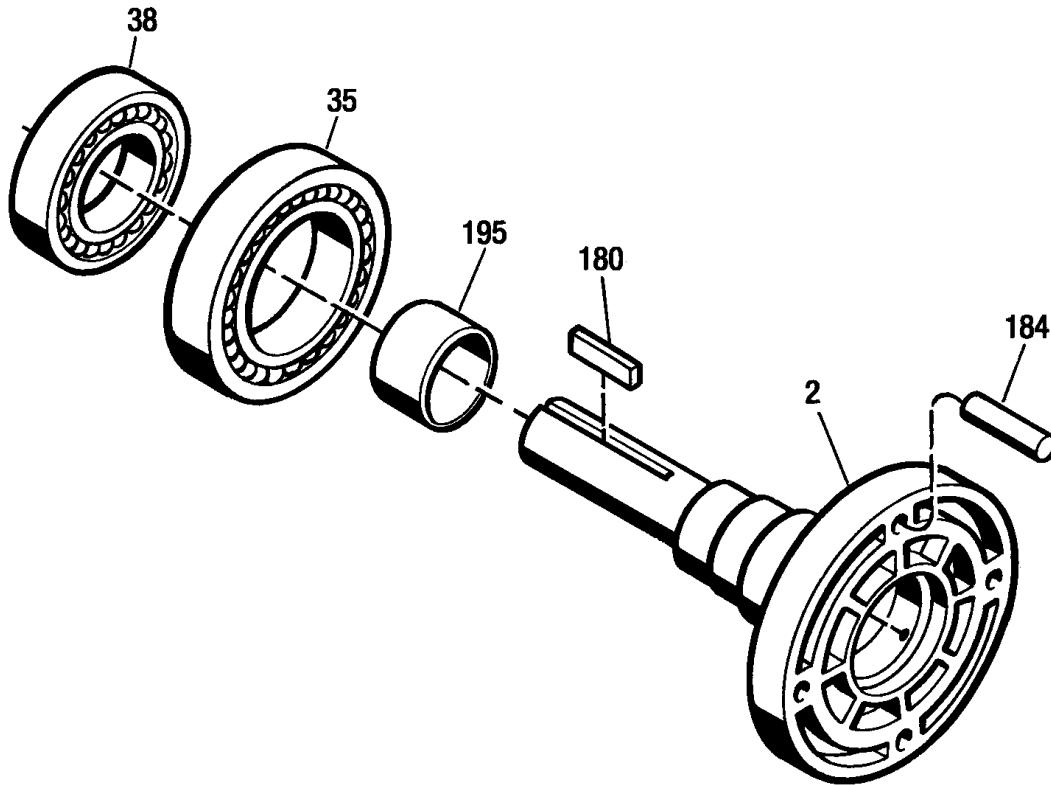

OPTIONAL 8-1/2" AK C-FACE ADAPTER (1.5 Posidyne Only)

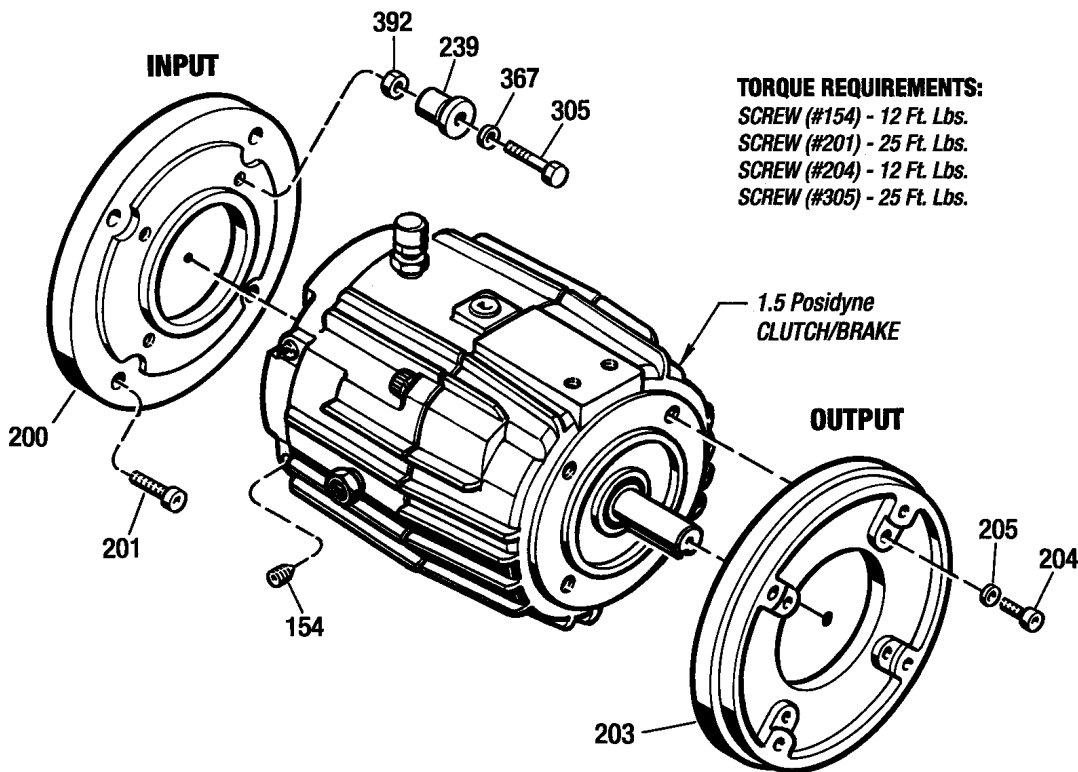

Figure 10.4 - Optional Extended Male Input Shaft and 8-1/2" AK C-Face Adapter

OPTIONAL MANIFOLD MOUNTED CONTROL VALVES
OPTIONAL OPTICAL ENCODER ASSEMBLY

(Figure 10.5)

REF. No.	PART NAME	QTY.	REF. No.	PART NAME	QTY.
17	Encoder Housing.....	1	372	Top Cover.....	1
18	Upper Enclosure.....	1	373	Insulator.....	1
*19	Gasket	2	700	Manifold Mounted Control Valve.....	1
76	Hex Hd. Screw.....	4	701	Manifold Spacer.....	1
77	Soc. Hd. Screw.....	2	725	Cap Screw.....	2
154	Set Screw	1	727	Cap Screw.....	4
186	Optical Disc Assembly.....	1	737	Lockwasher.....	2
225	But.Hd. Screw.....	4	738	Seal.....	2
234	Key.....	1	767	Pressure Gauge	
257	Lockwasher.....	4		1-PC-3/8" Valve.....	1
259	Cable	1		2-PC-3/8" Valve.....	2
260	Cable Grommet	1	*807	Manifold Gasket.....	1
269	Dirt Seal.....	1	*808	O-Ring	2
355	Circuit Board.....	1	810	Locating Tube.....	1
356	Jumper.....	1	811	Fastener.....	2
368	Cable Connector.....	1			

* - Indicates parts in Minor Overhaul Kit.

OPTIONAL MANIFOLD MOUNTED CONTROL VALVE

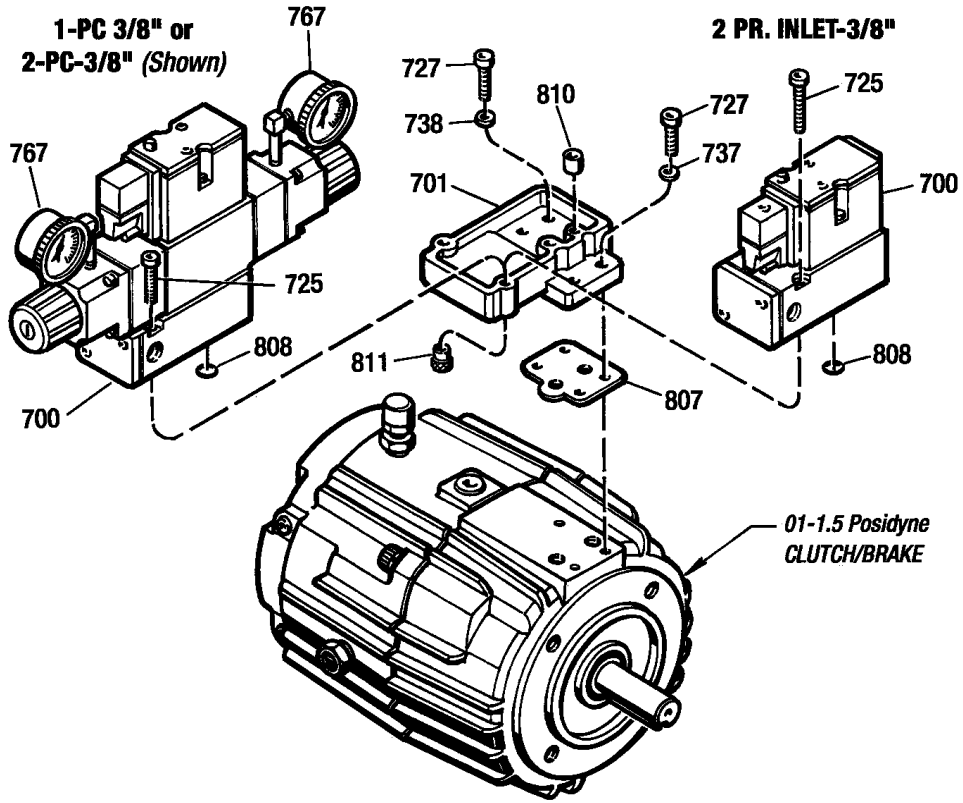

OPTIONAL OPTICAL ENCODER ASSEMBLY

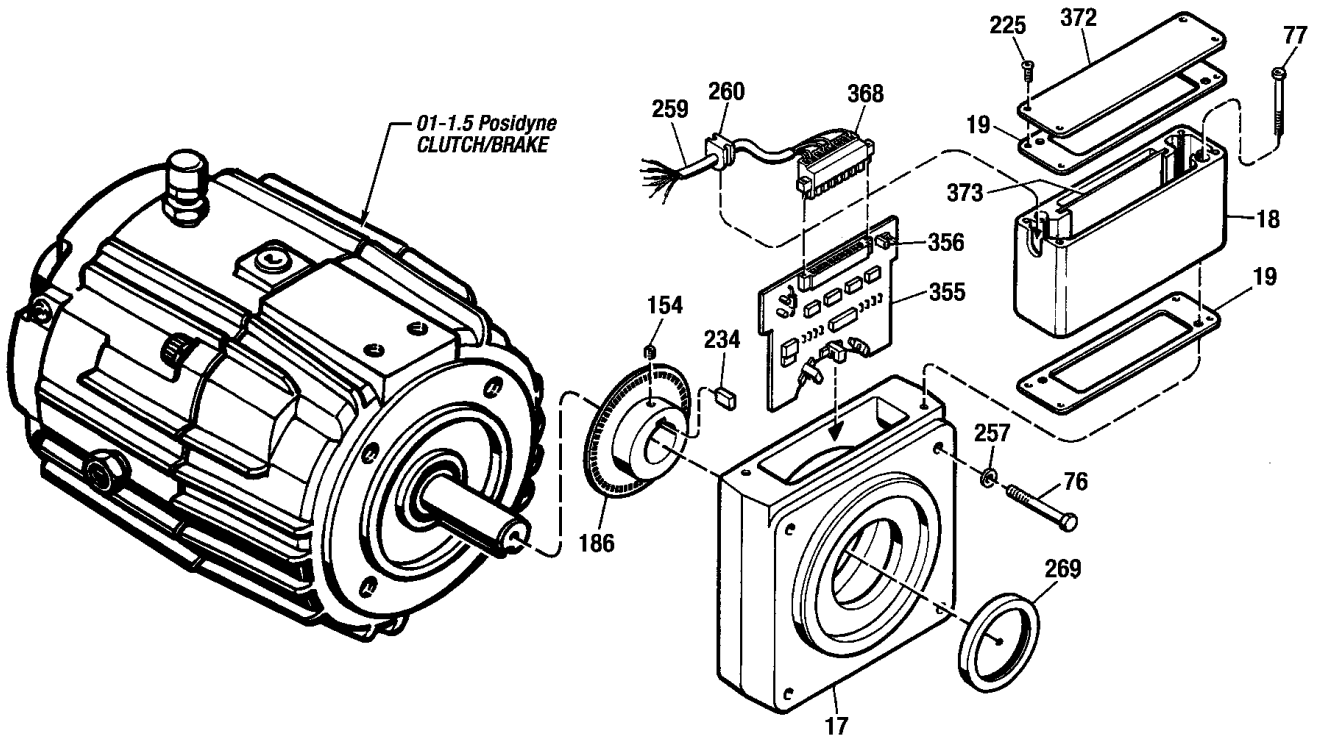

Figure 10.5 - Optional Manifold Mounted Control Valve and Optical Encoder Assembly

OPTIONAL FAN COOLING

(Figure 10.6)

REF. No.	PART NAME	QTY.	REF. No.	PART NAME	QTY.
24	Fan Shroud.....	1	239	Mounting Spool, Short.....	4
25	Cooling Fan.....	1	**251	Tolerance Ring.....	1
66	Hex. Hd. Cap Screw.....	4	367	Lockwasher.....	4
154	Cone Point Set Screw	4			

** Indicates parts in Major Overhaul Kit. (Plus all parts in Minor Overhaul Kit.)

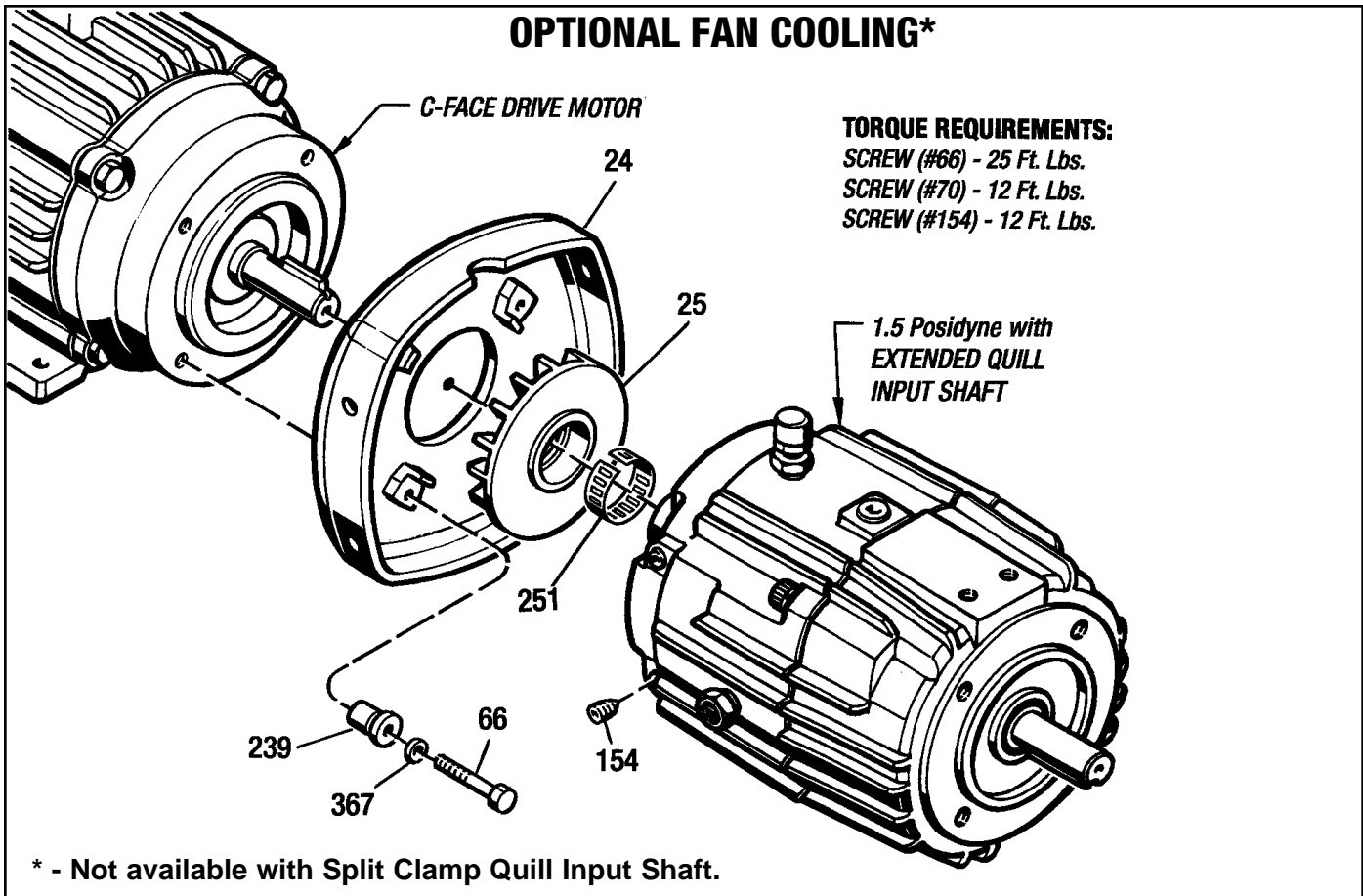

Figure 10.6 - Optional Fan Cooling

OPTIONAL FOOT MOUNTING

(Figure 10.7)

REF. No.	PART NAME	QTY.	REF. No.	PART NAME	QTY.
66	Hex. Hd. Cap Screw.....	4	265	Lockwasher.....	2
154	Cone Point Set Screw.....	4	367	Lockwasher	
165	Foot Mounting Bracket	2		Foot Mounting Only.....	2
221	Mounting Spool, Long (C-Face Motor).....	2		Foot Mounting, C-Face Motor.....	4
239	Mounting Spool, Short			Fan Cooled with Foot Mounting.....	4
	Foot Mounting Only.....	2	392	Hex. Nut	
	Fan Cooled with Foot Mounting.....	4		Foot Mounting Only.....	2
263	Hex. Hd. Cap Screw.....	2		Fan Cooled with Foot Mounting.....	4
264	Flat Washer (Without Fan Cooling).....	2			

OPTIONAL FOOT MOUNTING

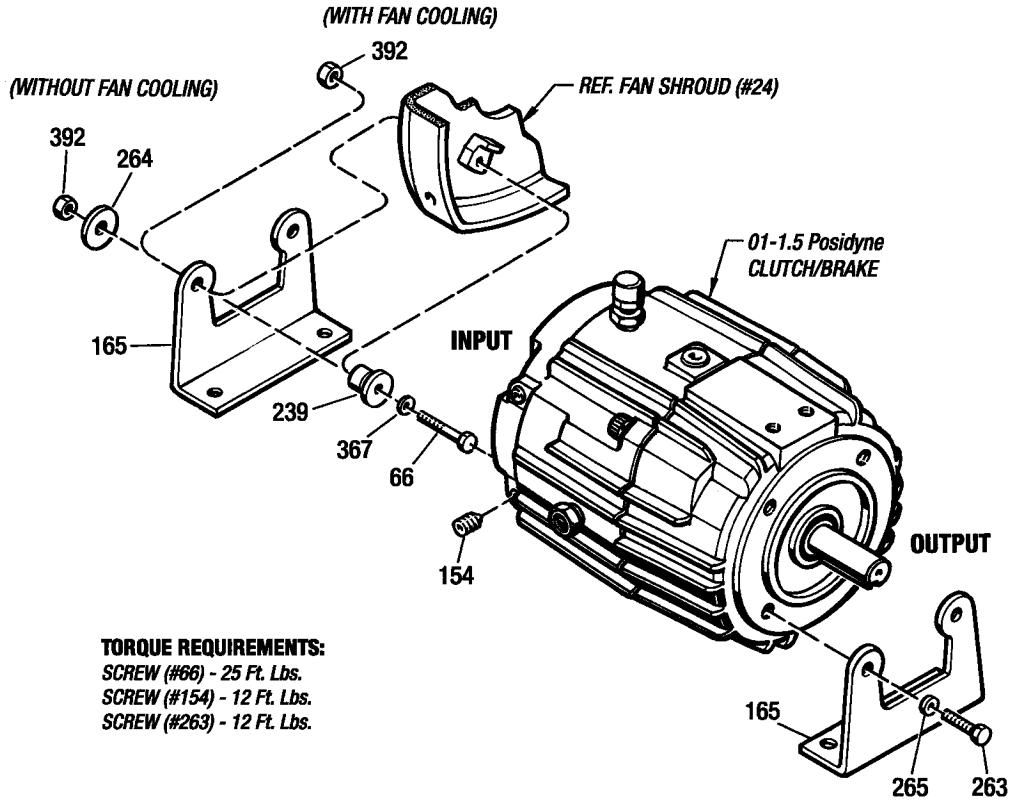

OPTIONAL FOOT MOUNTING (With C-Face Motor)

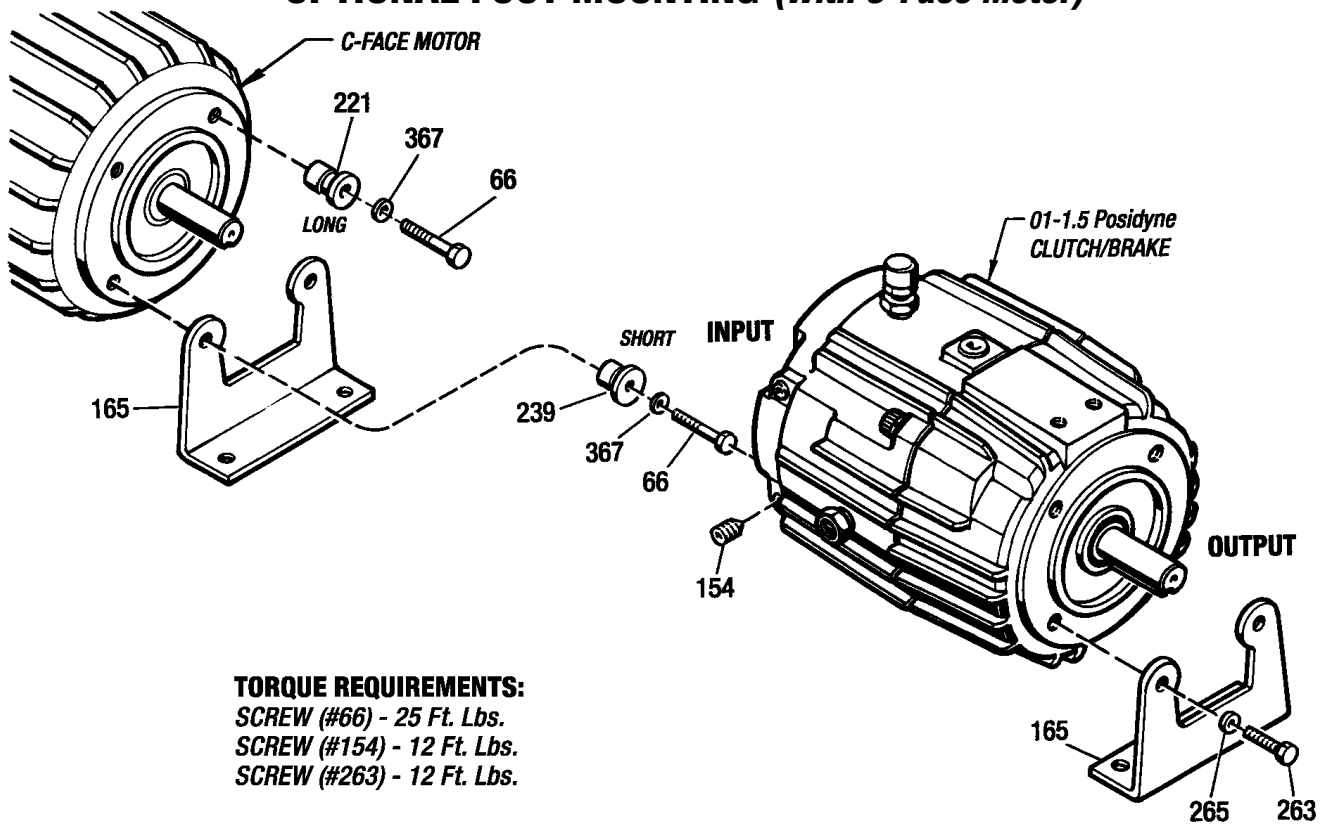

Figure 10.7 - Optional Foot Mounting

VERTICAL INSTALLATION KITS

(Figures 10.8 & 10.9)

REF. No.	PART NAME	QTY.	REF. No.	PART NAME	QTY.
*6	Brake Pressure Plate (Not on "C" Logic).....	1	82	Pipe Nipple	1
*12	Friction Disc		90	Reducer Bushing (01 Posidyne Only)	1
	01 - "A", "B", "S" and "SA" Logic.....	4	92	Sq. Hd. Mag. Pipe Plug.....	1
	01 - "C" Logic	2	101	Reducer Bushing (01 Posidyne Only)	1
	1.5 - "A", "B", "S" and "SA" Logic.....	6	136	90° Elbow.....	1
	1.5 - "C" Logic	3	144	Hose.....	1
*13	Drive Plate, Standard		145	Hose Fitting.....	1
	01 - "A", "B", "S" and "SA" Logic.....	6	146	90° Swivel Hose Adapter.....	1
	01 - "C" Logic	3	147	Hose Fitting.....	1
	1.5 - "A", "B", "S" and "SA" Logic.....	2	*229	Separator Spring (1.5 Posidyne)	
	1.5 - "C" Logic	1		"A", "B", "S" and "SA" Logic	24
20	Accumulator.....	1		"C" Logic.....	12
**45	Breather.....	1	*323	Drive Plate, with rivets (1.5 Posidyne)	
**46	Sight Gauge.....	1		01 - "A", "B", "S" and "SA" Logic.....	6
73	Reducer Bushing.....	1		01 - "C" Logic	3
74	Pipe Plug	1	*349	Separator Spring (01 Posidyne)	
81	Pipe Nipple	1		"A", "B", "S" and "SA" Logic.....	8

* - Indicates parts in Minor Overhaul Kit.

** - Indicates parts in Major Overhaul Kit. (Plus all parts in Minor Overhaul Kit.)

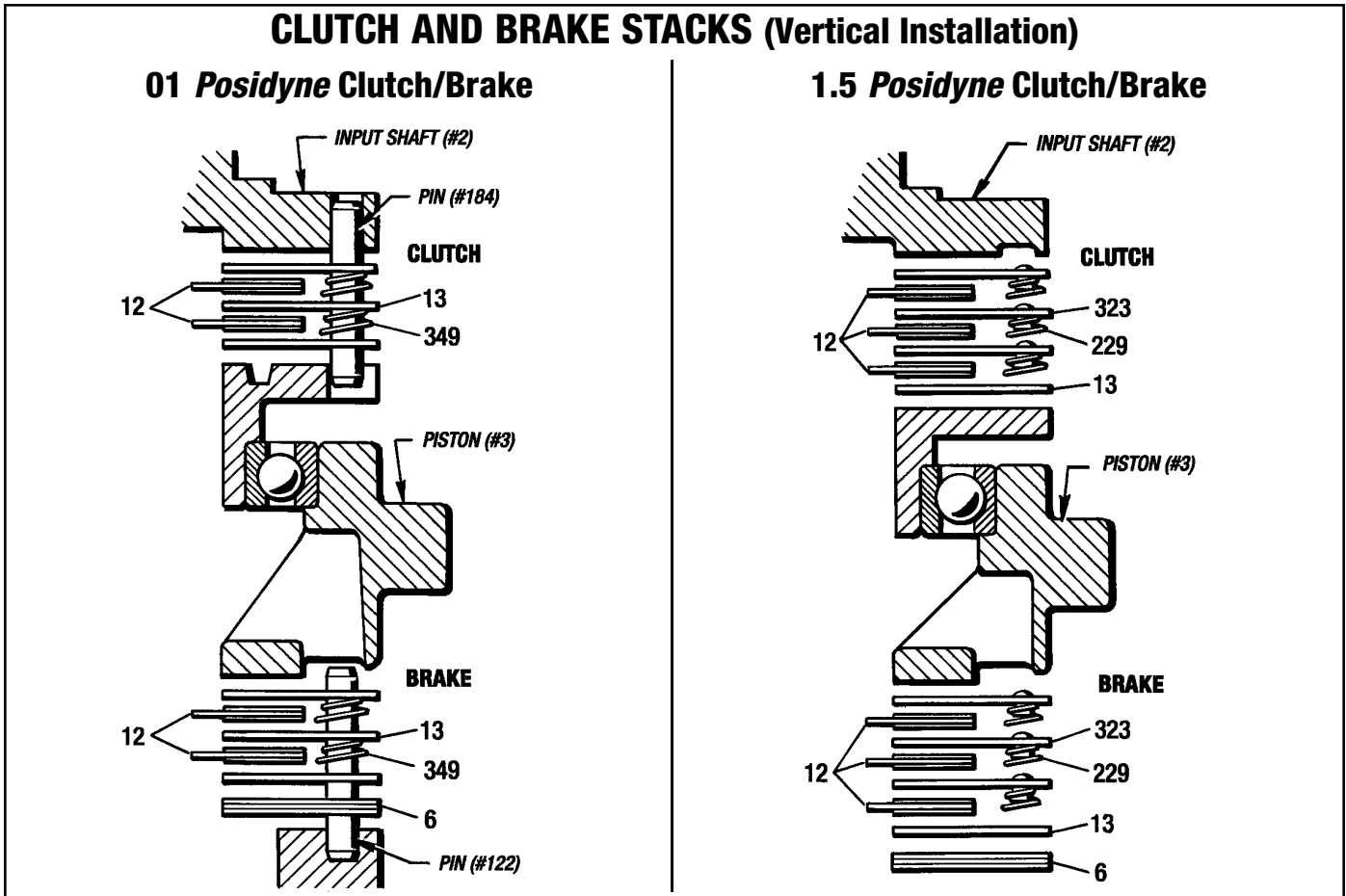
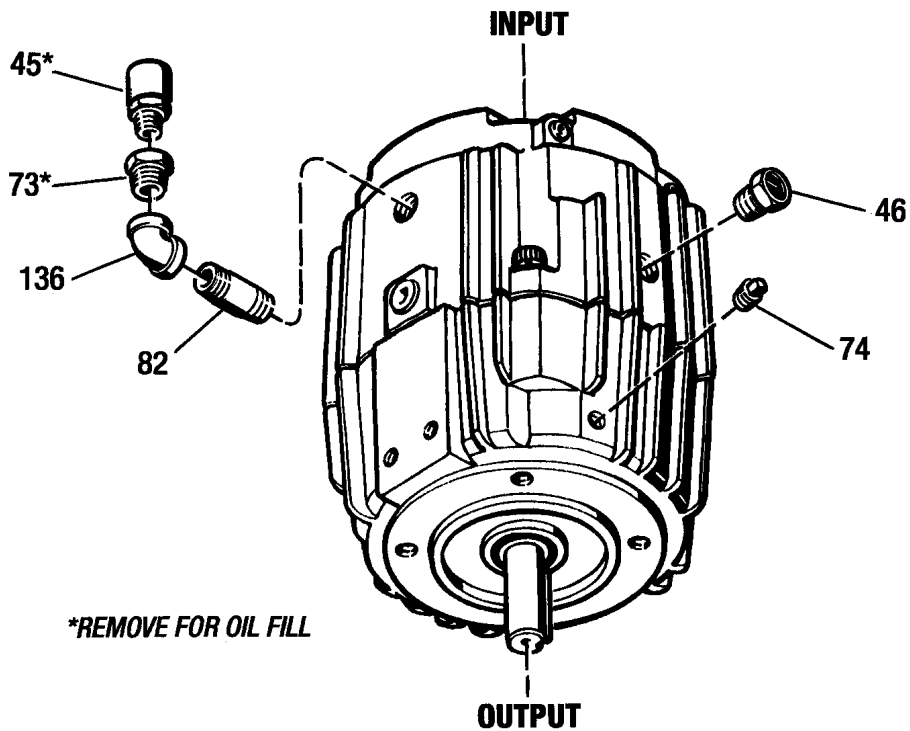

Figure 10.8 - Clutch and Brake Stacks (Vertical Installation)

VERTICAL INSTALLATION KITS (VERTICAL - INPUT UP)



(VERTICAL - INPUT DOWN)

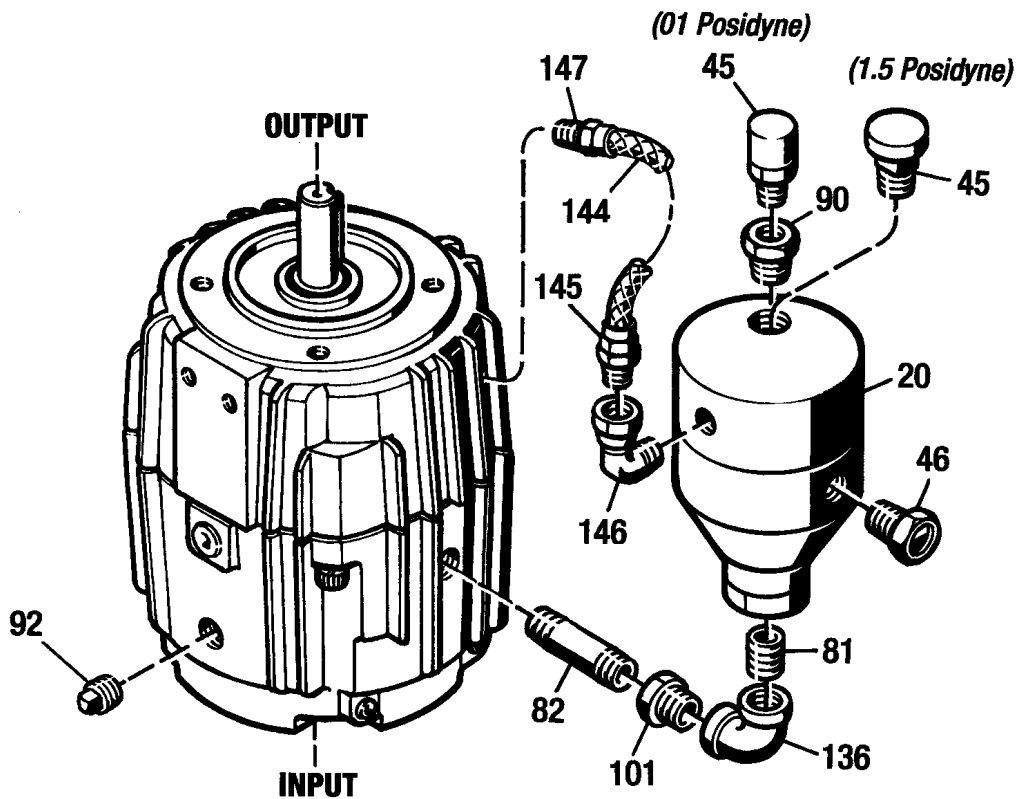
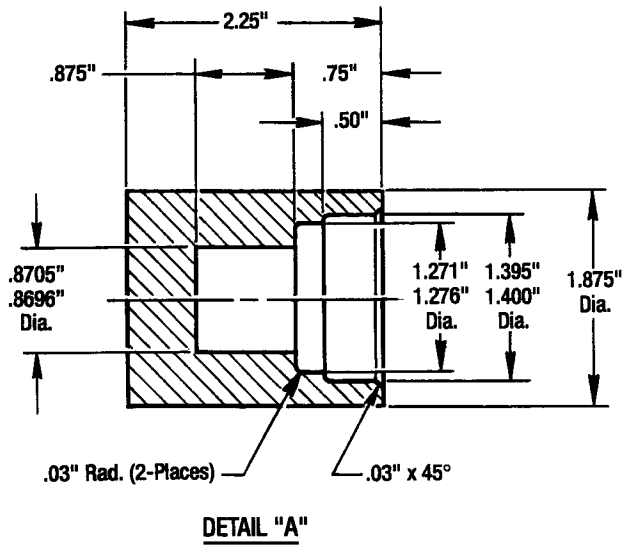

Figure 10.9 - Vertical Installation Kits

Size 01 *Posidyne* Special Assembly Tools

A 5/8" Dia. Quill Input Shaft - Wear Sleeve (#195) (Part No. 601-01-008)



Material: Mild Steel

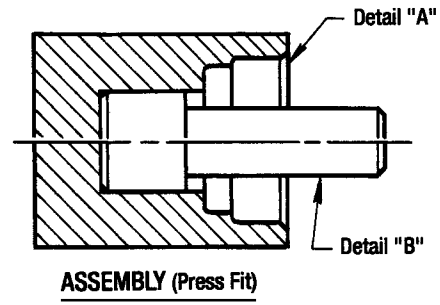
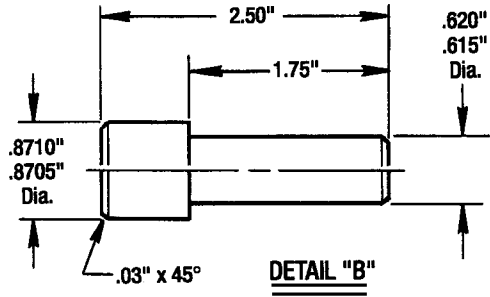

B 7/8" Dia. Quill Input Shaft - Wear Sleeve (#195) (Part No. 601-01-009)

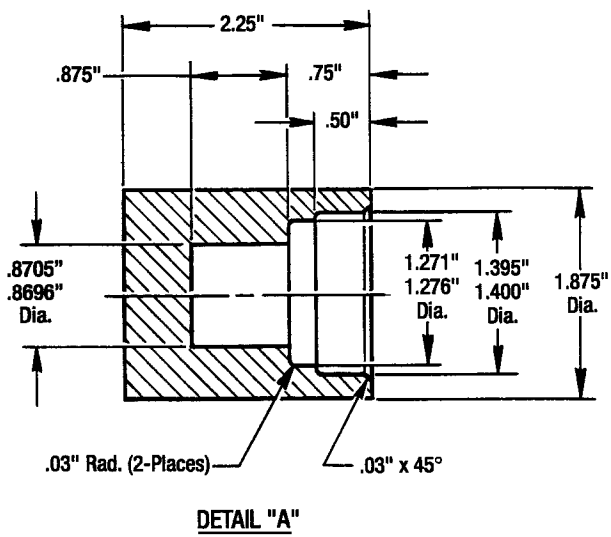

Material: Mild Steel

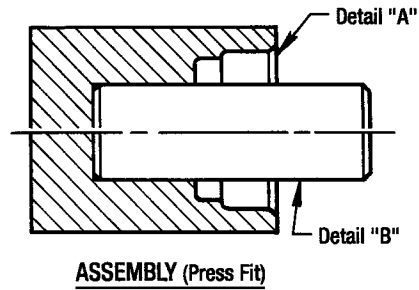
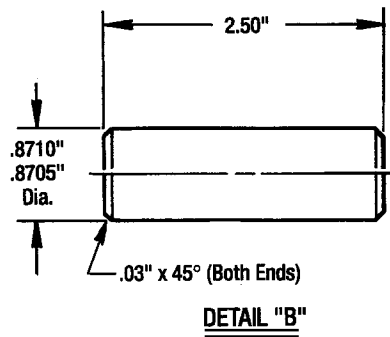

Size 01 *Posidyne* Special Assembly Tools

C 5/8" Dia. Split Quill Input Shaft - Wear Sleeve (#195)
(Part No. 601-01-013)

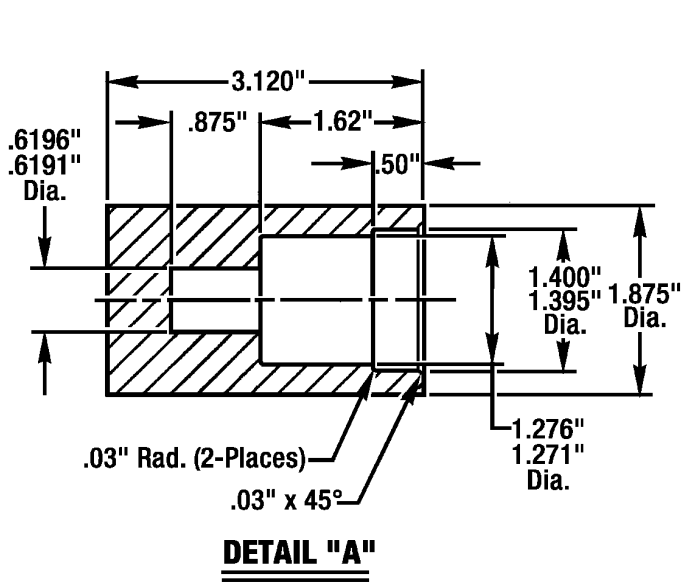

Material: Mild Steel

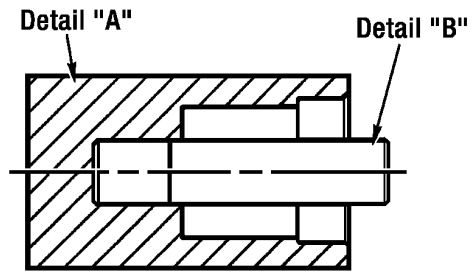
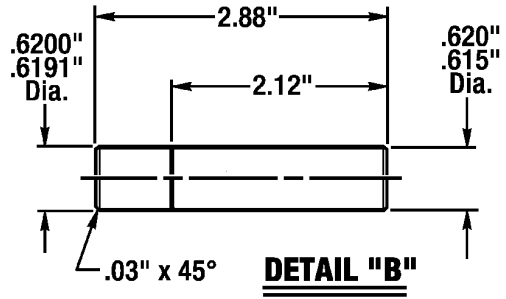

D 7/8" Dia. Male Input Shaft - Wear Sleeve (#195)
(Part No. 601-01-005)

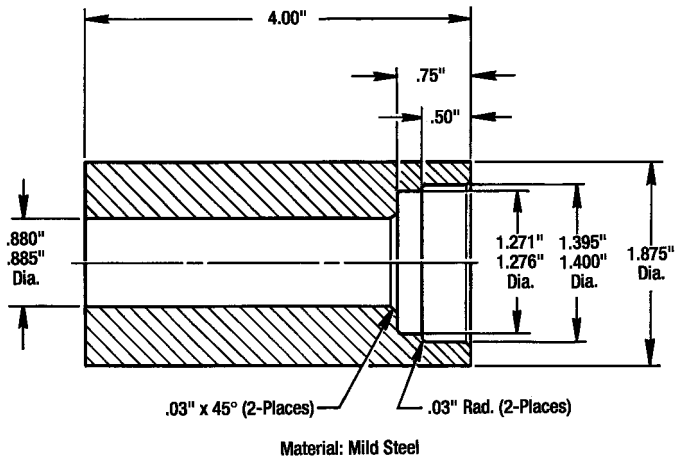

E 7/8" Dia. Male Input Shaft - Bearing (#38)
(Part No. 601-01-006)

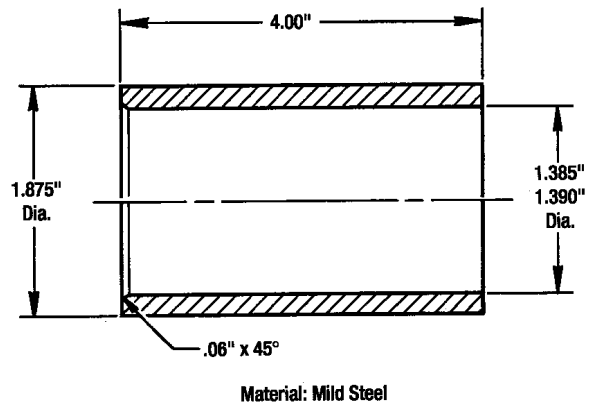

Size 01 *Posidyne* Special Assembly Tools

F 7/8" Dia. Male Input Shaft - Bearing (#35)
(Part No. 601-01-010)

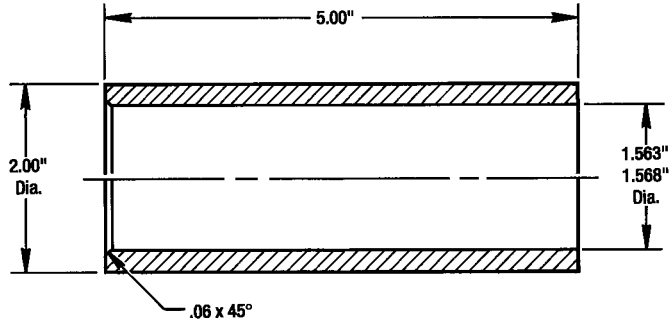

Material: Mild Steel

G Quill Input Shaft - Bearing (#35)
(Part No. 601-01-003)

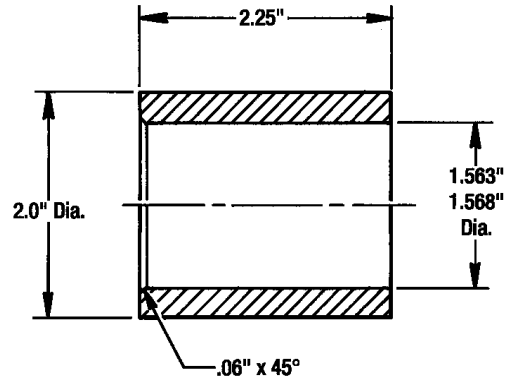

Material: Mild Steel

H 5/8" Dia. Output Shaft - Bearing (#26) and
Mating Ring (#4) (Part No. 601-01-002)

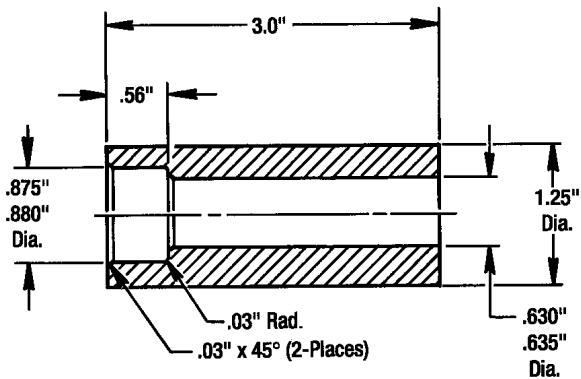

Material: Mild Steel

I 7/8" Dia. Output Shaft - Bearing (#26) and
Mating Ring (#4) (Part No. 601-01-011)

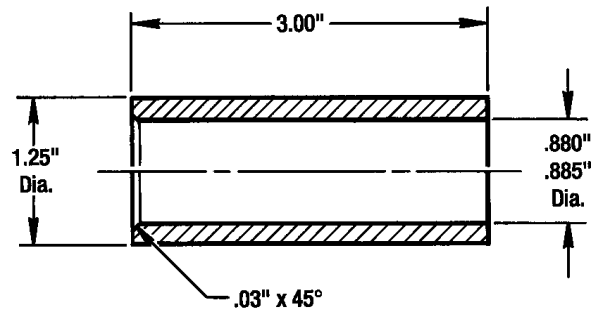

Material: Mild Steel

Size 1.5 *Posidyne* Special Assembly Tools

J 5/8" Dia. Quill Input Shaft - Wear Sleeve (#195) (Part No. 601-1.5-006)

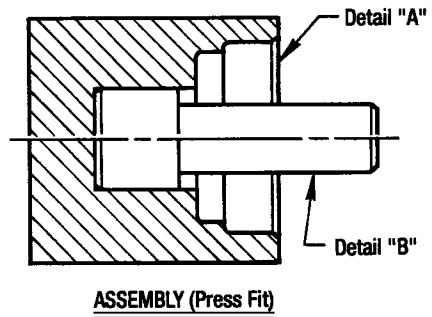
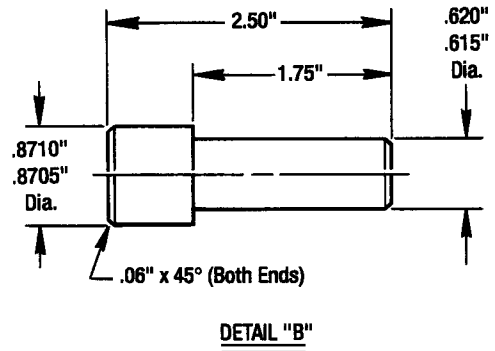
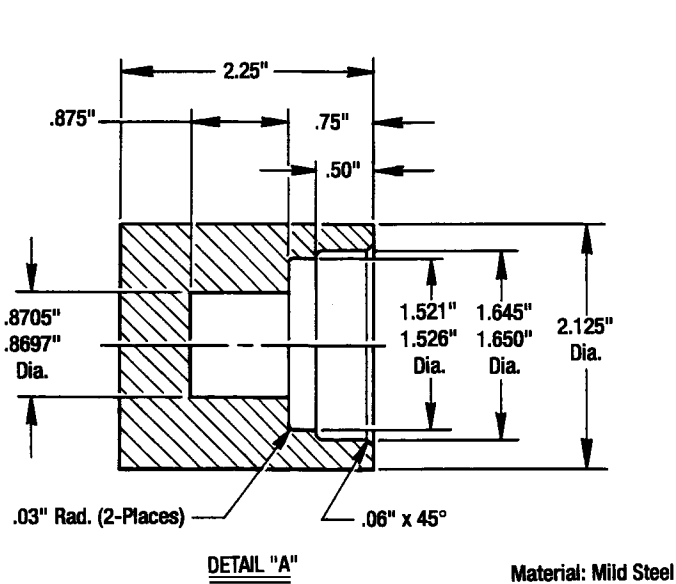

K 7/8" Dia. Quill Input Shaft - Wear Sleeve (#195) (Part No. 601-1.5-001)

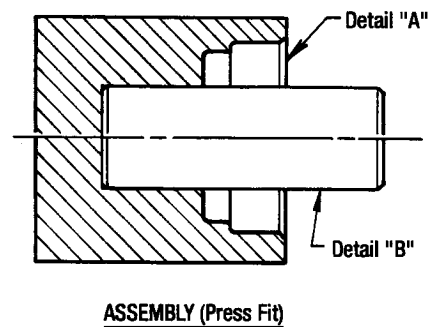
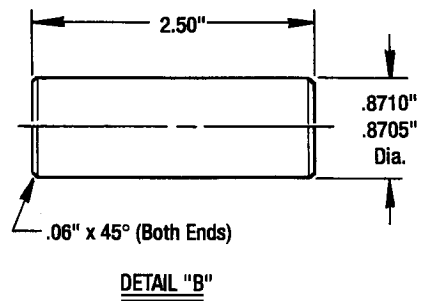
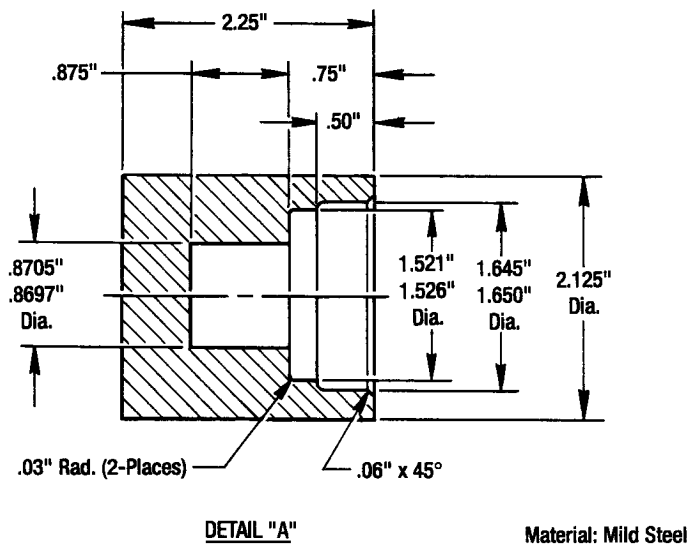

Size 1.5 *Posidyne* Special Assembly Tools

L 1-1/8" Dia. Quill Input Shaft - Wear Sleeve (#195) (Part No. 601-1.51-011)

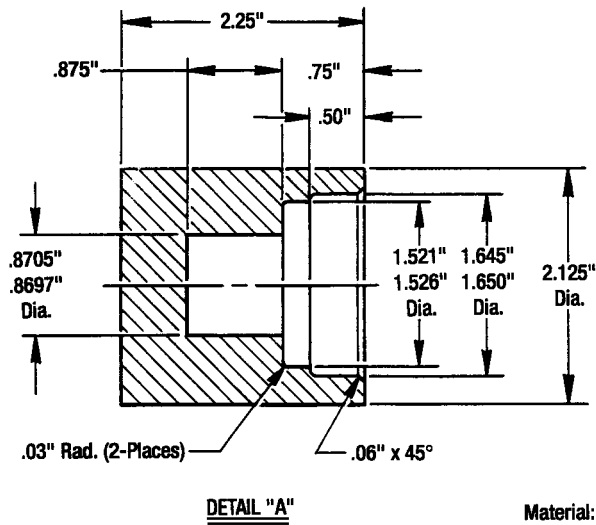

Material: Mild Steel

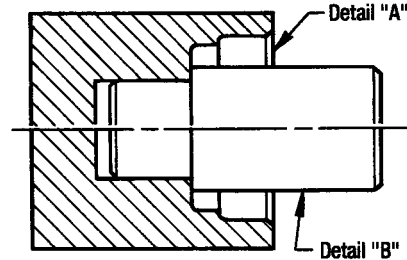
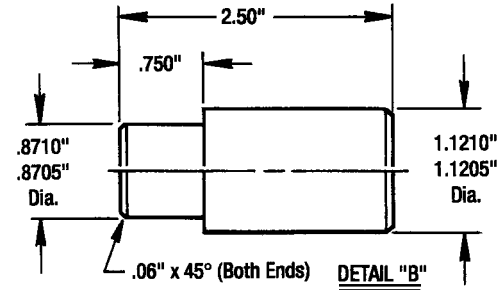

ASSEMBLY (Press Fit)

M 5/8" - 7/8" Dia. Split Quill Input Shaft - Wear Sleeve (#195) (Part No. 601-1.5-017)

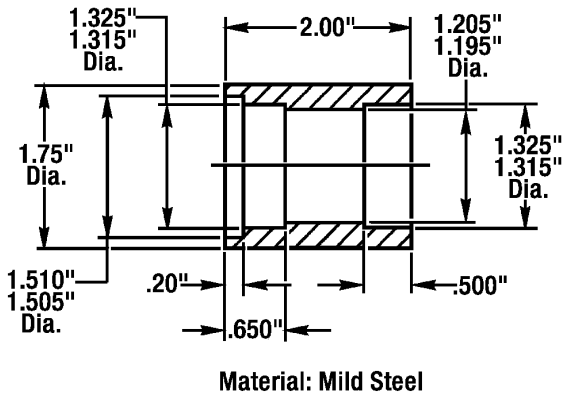

N 7/8" Dia. Male Input Shaft - Wear Sleeve (#195) (Part No. 601-1.5-009)

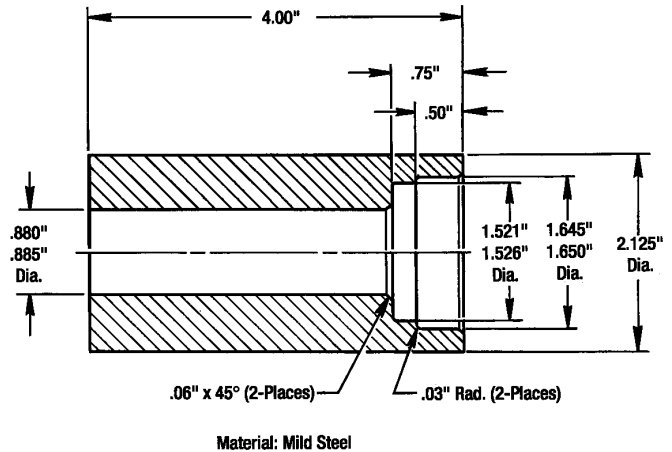

O 7/8" Dia. Male Input Shaft - Bearing (#38) (Part No. 601-1.5-013)

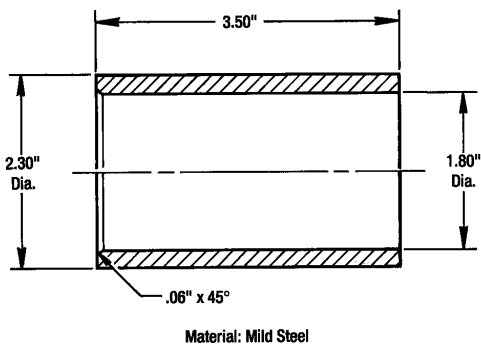

P Quill Input Shaft - Bearing (#35) (Part No. 601-1.5-003)

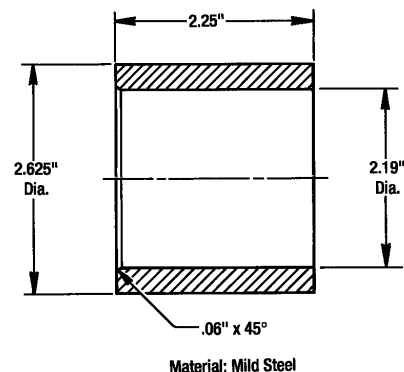

Size 1.5 *Posidyne* Special Assembly Tools

Q Male Input Shaft - Bearing (#35)
(Part No. 601-1.5-012)

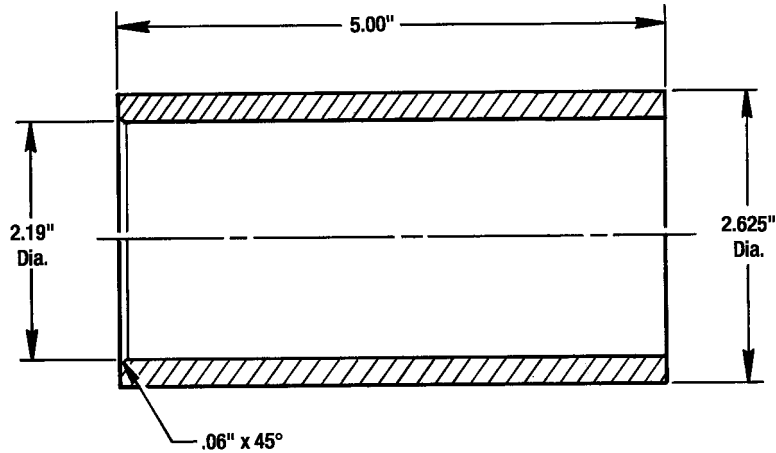

R 5/8" Dia. Output Shaft - Wear Sleeve (#236)
and Bearing (#26) (Part No. 601-1.5-008)

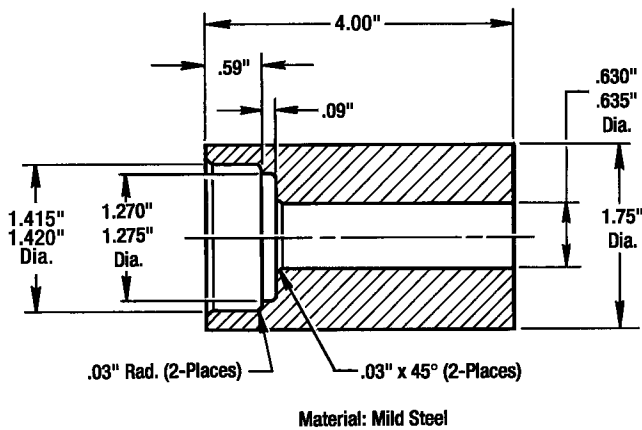

S 7/8" Dia. Output Shaft - Wear Sleeve (#236)
and Bearing (#26) (Part No. 601-1.5-002)

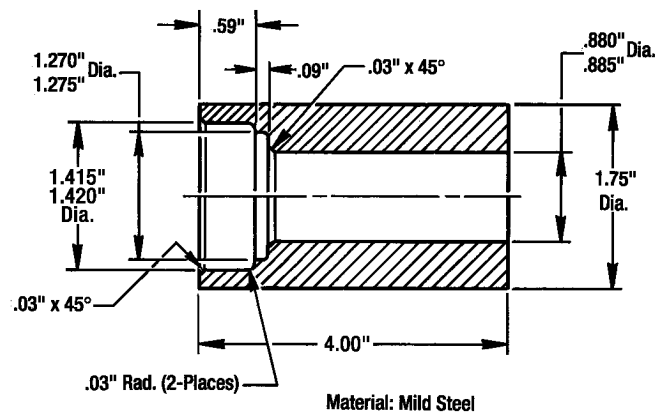

T 1-1/8" Dia. Output Shaft - Wear Sleeve (#236)
and Bearing (#26) (Part No. 601-1.5-015)

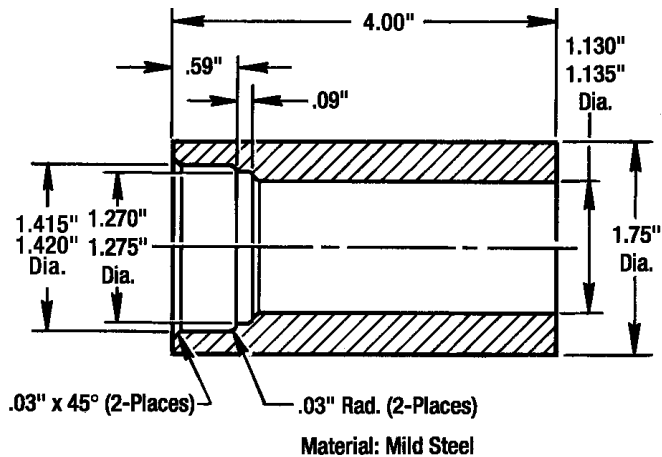

U 24 mm Dia. Output Shaft - Wear Sleeve (#236)
and Bearing (#26) (Part No. 601-1.5-022)

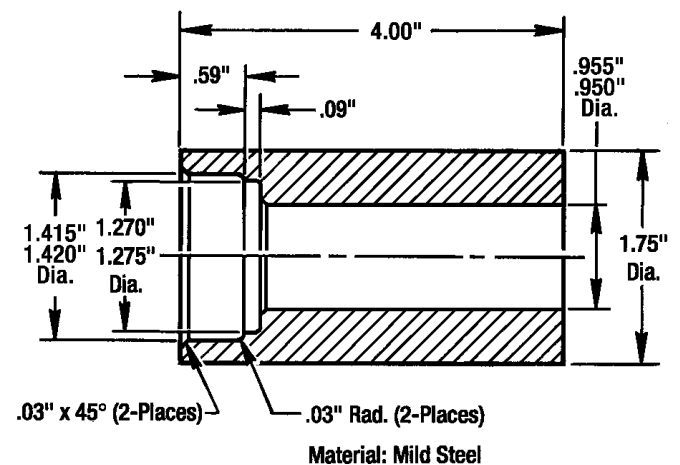

FORCE CONTROL INDUSTRIES, INC.

Worldwide Leader in Oil Shear Technology.

*Providing today's industries
with Oil Shear Clutch and
Brake Drives that delivers:
Flexibility • Efficiency
Endurance • Performance
Dependability*

“Built to Last - Guaranteed to Perform”



FORCE CONTROL INDUSTRIES, Inc.

MAIN OFFICE

P.O. Box 18366
Fairfield, Ohio 45018

3660 Dixie Highway
Fairfield, Ohio 45014

Tel: (513) 868-0900

Fax: (513) 868-2105

E-Mail: info@forcecontrol.com

DETROIT OFFICE

24419 Sorrentino Court
Clinton Twp., Mich. 48035

Tel: (810) 792-7100

Fax: (810) 792-7329

E-Mail: info@forcecontrol.com