



# Barge Spotting Made Easy



The *Posidyne Clutch Brake* is the ideal tension control device for spotting barges.

- Smooth tension control in both directions
- Tension easily adjusted for upriver or down-river conditions
- Internal holding brake
- Totally enclosed water proof housing
- No adjustment, maintenance or disc replacement
- Simple control system

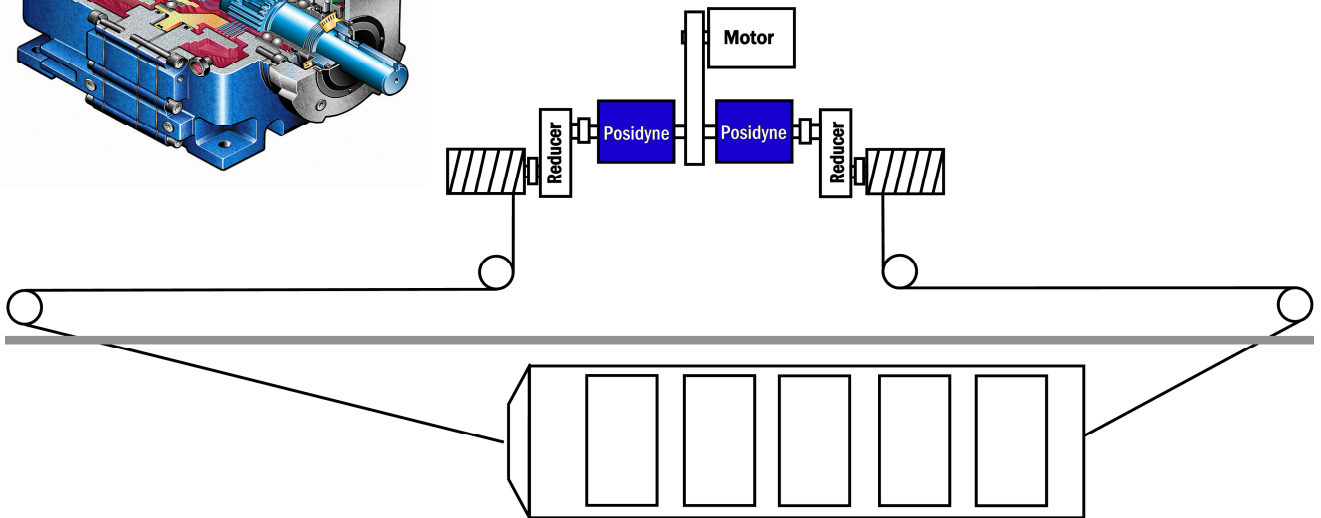
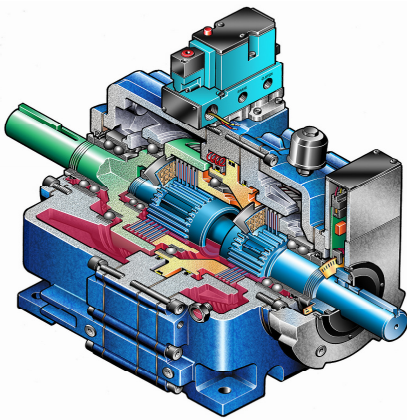

## Other Drive Arrangements

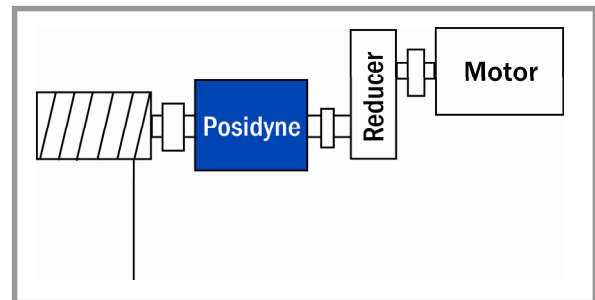
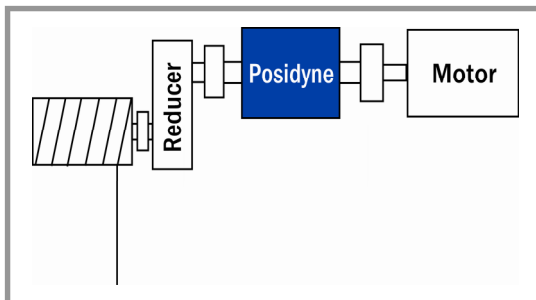



# Barge Spotting Made Easy

There are many systems today for setting barges in position along the dock for loading or unloading. The Posidyne clutch brake with Oil Shear Technology by Force Control Industries is unique.

**Oil Shear Technology** consists of transmission fluid strategically flowing between a set of plates and friction discs. This fluid will transmit torque, maintain separation between the plates and discs eliminating wear, and pulls the heat of engagement out of the stack. The torque is accurately controlled by controlling the squeeze pressure on the stack. Therefore, by accurately controlling the pneumatic or hydraulic actuation pressure, the tension or pulling torque is simply controlled with a pressure control regulator for the actuation pressure.

**How does it work?** One or two motors can be used to drive two clutch brakes each connected to a winch. In still water, setting the actuation pressure on both clutches will cause no movement, but will maintain tension on both cables. By increasing pressure on one clutch, the tension will increase, causing the barge to move in the direction of that winch while the pressure on the other clutch maintains tension as the winch tends to overrun the holding clutch.

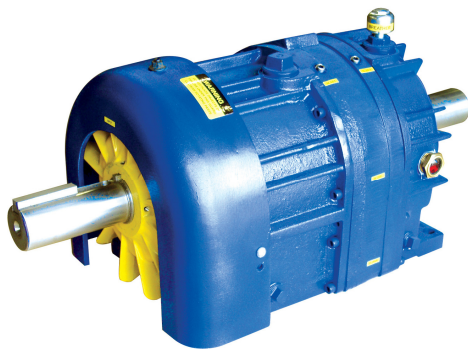

A brake is included in the Posidyne clutch brake unit that can be used when holding in position for longer periods of time.

**Advantages?** Smooth control. No harsh stopping and starting causing damage to cables and fittings. Use of standard motors that eliminate the need for special motors and controller for VFD units, which are susceptible to damage by lightning and saltwater port environment.

Long trouble free system useable in hazardous, or explosive environments such as chemical or fuel filling operations, coal or grain loading.

The *Posidyne Clutch Brake* is the ideal tension control device for spotting barges.

- Smooth tension control in both directions
- Tension easily adjusted for upriver or downriver conditions
- Internal holding brake
- Totally enclosed water proof housing
- No adjustment, maintenance or disc replacement
- Simple control system

**Call Today! 800-829-3244**

**Force Control Industries, Inc.**

Fairfield, Ohio USA

PHONE: 800-829-3244 FAX: 513-868-2105

Email: [info@forcecontrol.com](mailto:info@forcecontrol.com)