

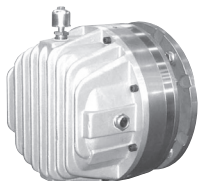

MB-250, MB-280 and MB-320 Motor Brake INSTALLATION MANUAL



DESCRIPTION



Posistop Motor Brakes are multiple surface, spring activated, pneumatic release braking devices that effectively dissipate the heat generated from electric motors requiring frequent starting and stopping,

This Manual covers the 3 largest sizes or models MB-250, MB-280 and MB-320. For information on other sizes and models not covered in this manual, contact the Force Control Factory or your Force Control Representative.

OPERATION

The *Posistop* Motor Brake Cross Section (*Figure 1*) shows the brake in the normally spring loaded braking position.

Compressed air, controlled by external valving, enters the piston housing and moves the piston to disengage the multiple braking disc stack, allowing the drive motor to rotate freely.

When the air pressure is released the piston (spring loaded) returns to the normal braking position.

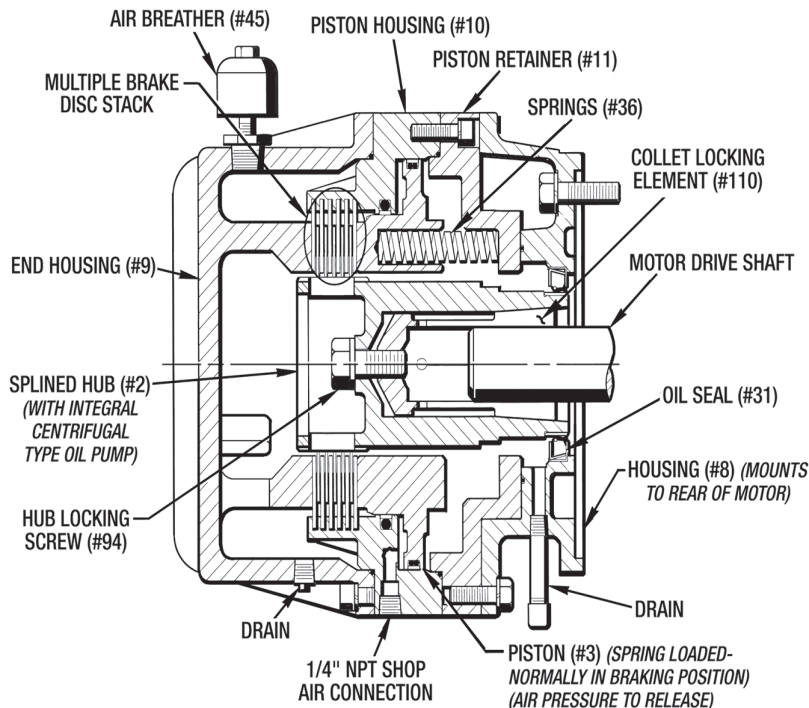

Figure 1 - Unit Description and Operation

INSTALLATION

IMPORTANT SAFETY PRECAUTIONS

The Brake Unit described in this manual must not be installed in any manner except as specified and must not be operated at speeds, torque loads or temperatures other than those specified. Failure to limit operation of the brake to the conditions specified could damage the unit and may cause malfunction or damage to interconnecting equipment.

WARNING - The following precautions must be taken if the installation of the *Posistop* Motor Brake is to be a retrofit for an existing application. Before attempting installation, open the motor disconnect, shut off the control electrical supply and lock them out to avoid any possibility of personal injury. Be sure any mechanisms holding inclined or vertical loads are locked mechanically with cribbing or other means.

The *Posistop* Motor Brake has been pre-assembled at the factory for ease of shipment. Partial disassembly will

be necessary to assemble the brake to the motor.

A. VERIFYING MOTOR SPECIFICATIONS

The Motor Manufacturer's Specifications must be verified first to ensure the Motor Brake Oil Seal Reliability. The Motor Shaft Runout, Mounting Face Runout and the Motor Shaft to Pilot Diameter Eccentricity need to be checked with a Dial Indicator as shown in Figure 2.

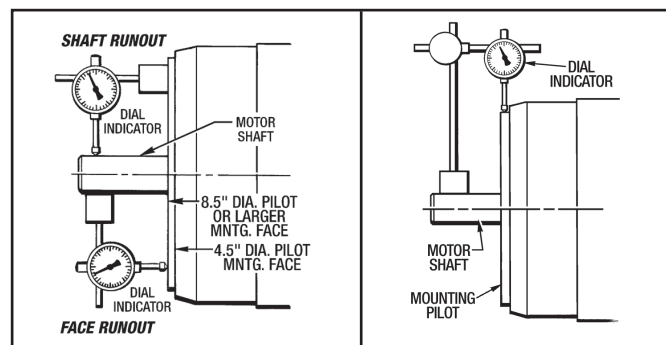

Figure 2 - Verifying Motor Specifications

MAXIMUM ALLOWABLE T.I.R. (Inches)
(As Per NEMA MG 1 Standard)

Pilot Dia. Dimensions	Tolerance on Pilot Dia.		Maximum Allowable Shaft Runout	Maximum Allowable Face Runout	Maximum Allowable Eccentricity
	Plus	Minus			
Less than 12"	.000"	.003"	.002"	.004"	.004"
12" or More	.000"	.005"	.003"	.007"	.007"

CAUTION - T.I.R. in excess of this maximum will result in a potential leak condition.

B. PARTIAL DISASSEMBLY

1. Remove the End Housing (#9) from the Piston Housing Assembly by removing the (8) Screws (#72) and (8) Lockwashers (#127). Back out screws evenly, housings are under spring pressure.

2. Pull the Brake Stack off of the lugs on the Piston Housing (#10).

IMPORTANT - Keep the Drive Plates and Friction Discs in the same order as removed.

3. Remove the (8) Screws (#151) and (8) Lockwashers (#129) that bolts the Housing (#8) to the Piston Housing Assembly.

NOTE - It is not necessary to disassemble the Piston Housing Assembly.

C. HOUSING (#8) TO DRIVE MOTOR

1. First check the motor shaft for any nicks or burrs. Cleanup and de-burr as necessary. Place a piece of masking tape over the motor shaft keyway to protect the Oil Seal (#31) during installation of the Housing (#8).

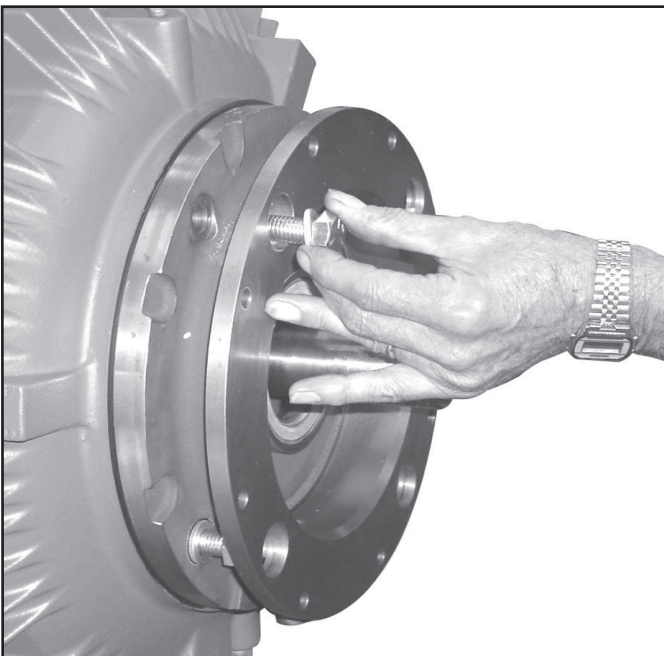

Figure 3 - Installing Housing (#8) to Drive Motor

2. Place the Housing (#8) onto the Motor Pilot Flange with the Drain Pipe (#77) located at the bottom.

CAUTION - Do not rest the weight of the Housing (#8) on the motor shaft. The sealing lip of the Oil Seal (#31) could be damaged causing leakage and premature failure of the motor brake.

3. Thread the (4) Hex Hd. Cap Screws (#150) and Lockwashers (#128) into the tapped holes on the motor flange face (See Figure 3). Torque 1/2"-13 hex hd. cap screws to 60 lb. ft. or 5/8"-11 hex hd. cap screws to **120 lb. ft.**

Check visually to make sure the sealing lip of the Oil Seal (#31) is undamaged.

Remove tape from keyway.

D. HUB ASSEMBLY TO MOTOR SHAFT

CAUTION - Do not use molybdenum disulfide "MOLYKOTE" or any other similar lubricant on the shaft. The collet hub locking element is keyless and depends on friction to transmit torque from the brake to the shaft.

1. The Collet (#110) is installed in Hub (#2) with a Hex Hd Cap Screw (#94) at the factory. To install the hub onto the shaft, remove Hex Hd. Cap Screw (#94) and Washer (#81) and coat the threaded end with Loctite Threadlocker #271 (or equal), and reinstall Screw and Sealwasher (#81), but do not tighten. The collet must be loose in its bore.

2. Apply a light coat of Vaseline or equivalent to the Wear Ring (#32). This will facilitate sliding the hub into the seal.

IMPORTANT - Again use special care not to damage the sealing lip of the oil seal when placing the hub assembly on the motor shaft.

3. Make sure the collet is loose in its bore, if not, back the Hex Hd Cap Screw (#94) out slightly and push it forward to push the collet toward the end of the hub, this will dislodge the collet from the tapered bore.

E. HUB ALIGNMENT

1. Tape a steel straightedge to the outer face of the housing as shown in Figure 4.

2. Tap the hub lightly to align the proper shoulder of the hub with the housing face (straightedge). This alignment should be within plus or minus 1/64" (See Figure 5).

3. After the Hub has been properly positioned, tightened the Hex Hd Cap Screw (#94) to specified torque. (See Figure 4).

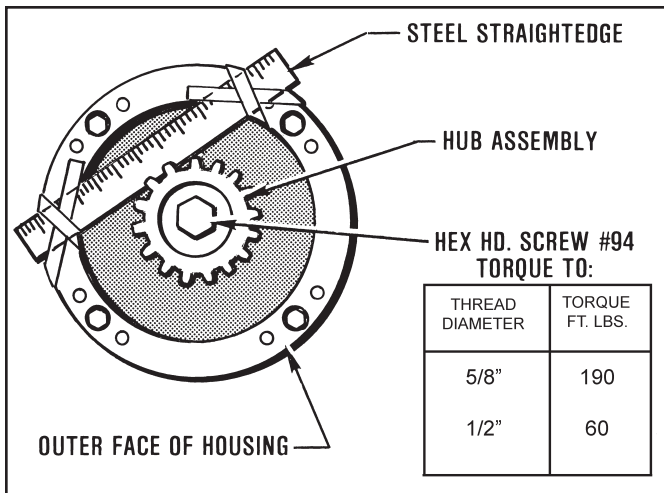

Figure 4 - Hub Alignment - Step 1

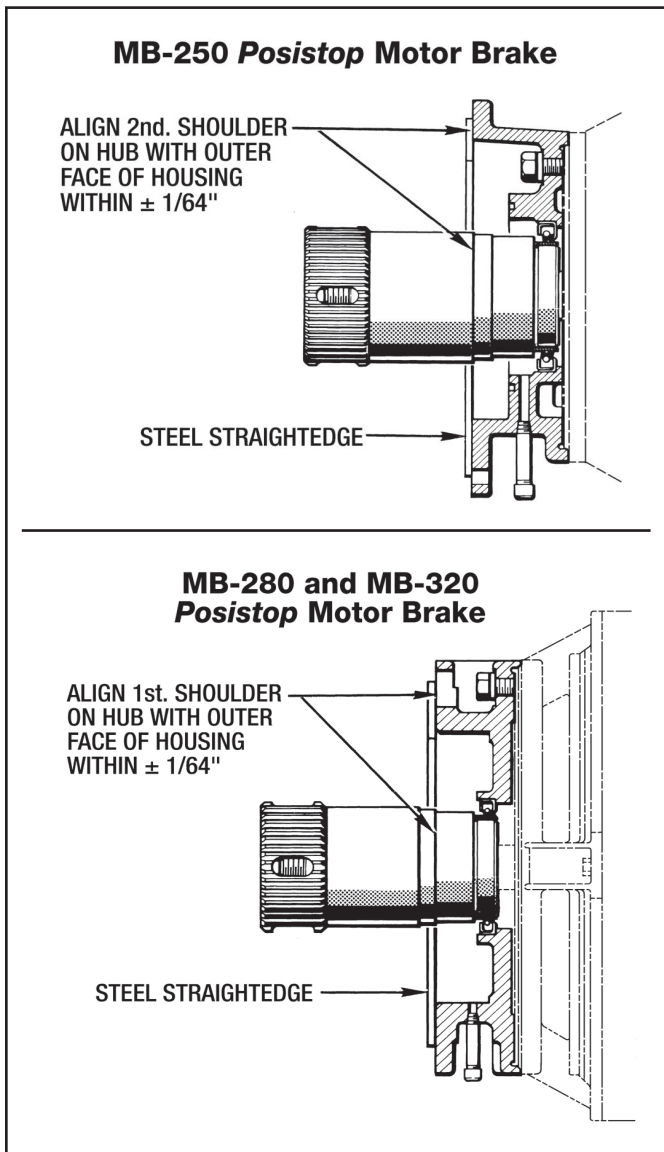

Figure 5 - Hub Alignment - Step 2

4. Recheck the alignment - if it is within tolerance, remove the straightedge.

F. PISTON HOUSING ASSEMBLY TO HOUSING (#8)

1. (MB-250) Lubricate the O-ring (#33) with Vaseline or equivalent and install into the O-ring groove in Housing (#8). (MB-280, MB-320) Lubricate the O-ring (#33) with Vaseline or equivalent and install it onto the Piston Assembly (See Figure 6).

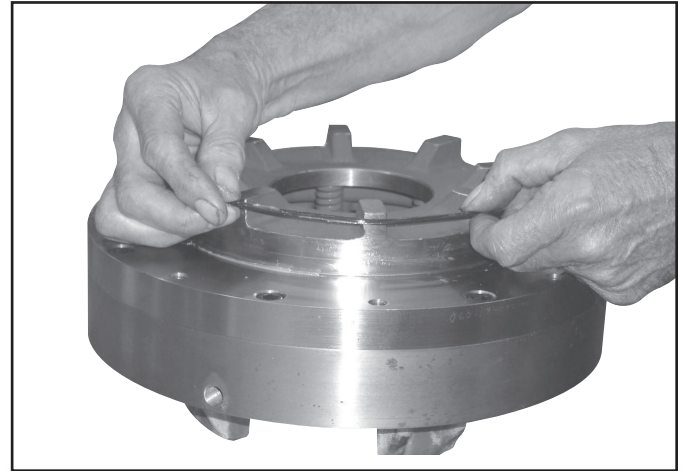

Figure 6 - Installing O-Ring (#33)

2. Carefully guide the Piston Housing Assembly into the mating diameter of the Housing (#8). See Figure 7 for the position of the brake lugs and the 1/4" NPT brake port

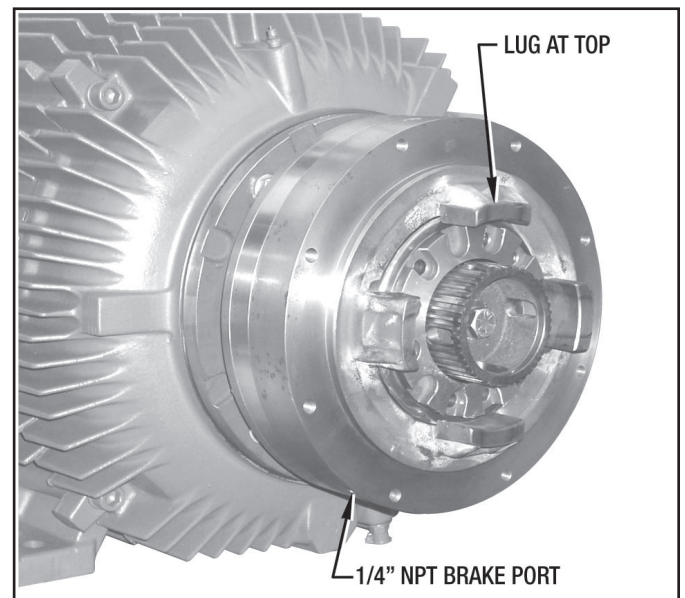

Figure 7 - Correct Position of Piston Housing Assembly

3. Using (8) Hex Hd. Cap Screws (#151) and Lockwashers (#129) bolt the Piston Housing Assembly to the Housing (#8).

G. INSTALLATION OF DRIVE PLATES AND FRICTION DISCS

USE THE ASSEMBLY SEQUENCE SHOWN BELOW FOR THE STATIC TORQUE (Lb. Ft.) REQUIRED.

MOTOR BRAKE TORQUE ASSEMBLY CONFIGURATIONS

A		B	
DRIVE PLATES		DRIVE PLATES	
FRICTION DISCS		FRICTION DISCS	
MODEL NUMBER	NOMINAL STATIC TORQUE (Lb. Ft.)	NUMBER OF SPRINGS	TORQUE ASSEMBLY CONFIG. (Above)
MB-250	75	2	A
	150	4	
	225	6	
	300	8	
MB-280	75	2	B
	150	4	
	225	6	
	300	8	
MB-320	120	3	B
	150	3	A
	200	4	
	300	6	
	450	8	

1. Apply shop air to the 1/4" N.P.T. connection at the bottom of the Piston Housing Assembly so the piston will retract fully. See **Table below for minimum release pressure.**

MINIMUM PRESSURE TO RELEASE

BRAKE SIZE	STATIC TORQUE (Lb. Ft.)	MINIMUM PRESSURE TO RELEASE (PSI)
MB-250 MB-280	75	18
	150	32
	225	46
	300	60
MB-320	120	23
	150	23
	200	30
	300	42
	450	62

2. While air pressure is being applied, install Drive Plates (#12) and Friction Discs (#13) as determined by the **Torque Assembly Configurations Chart** and as shown in *Figure 8*.

ASSEMBLY TIPS:

One side of the Steel Drive Plates has a slight radius on all edges due to the manufacturing process.

Install the radius side first, tilting the Drive Plate slightly to get it started.

The Friction Discs will also start onto the Splined Hub more easily if tilted slightly (*See Figure 8*).

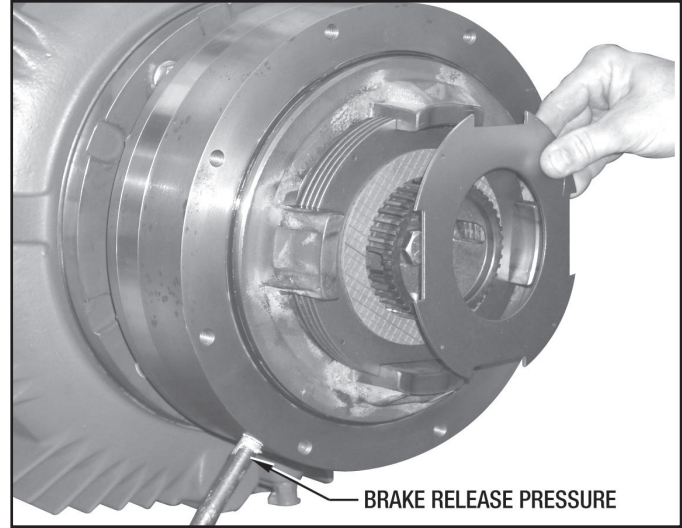

Figure 8 - Installing Brake Stack

H. END HOUSING TO BRAKE ASSEMBLY

1. Lubricate O-ring (#30) with a light coating of Vaseline or equivalent and place it on the Piston Assembly. (*See Figure 9*).
2. Place the End Housing (#9) onto the Piston Housing Assembly. (*See Figure 9*)

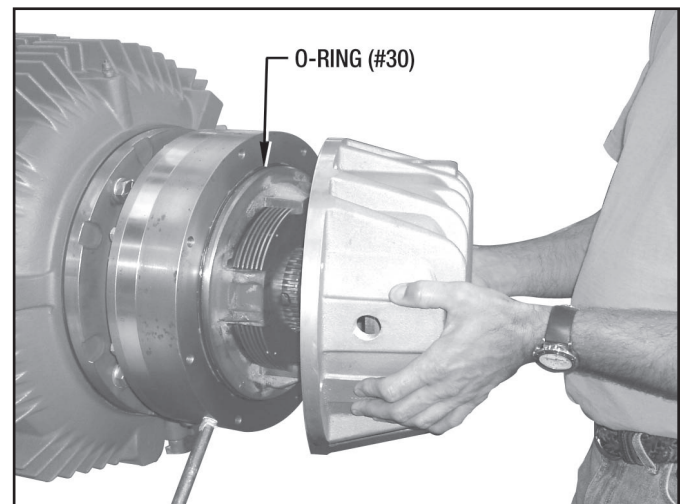

Figure 9 - Installing End Housing (#9)

NOTE

The Breather (#45) is to be located on the top as shown in *Figure 10*.

Attach the End Housing with (8) Soc. Hd. Cap Screws (#72) and Lockwashers (#128) to a torque reading of **37 lb. ft.** (See *Figure 10*).

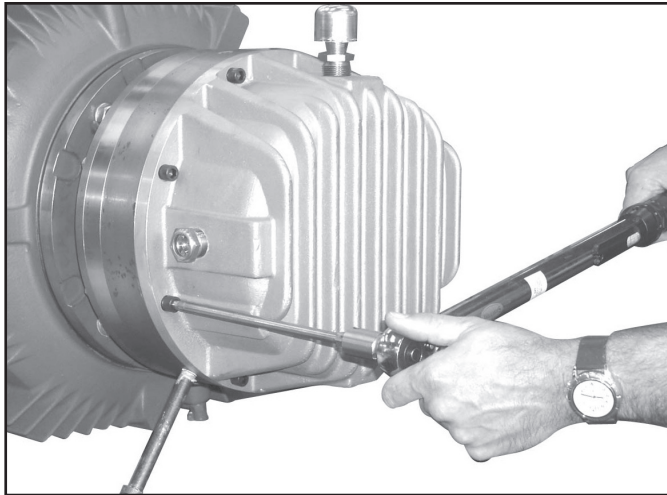

Figure 10 - Attaching End Housing

IT IS NOW SAFE TO RELEASE THE PISTON AIR PRESSURE.

3. Check the End Housing to see if Sight Gauge (#46), Air Breather (#45), Drain Plug (#74) and Pipe Plug (#73) are installed tightly.
4. Add automatic transmission oil (Mobil ATF-210) until oil level is in the center of the Sight Gauge (#46).
5. Install appropriate external pneumatic valving (See *Figure 11* for Control Valve Schematic and Logic).

The Solenoid Operated Air Valve used to control the operation of the Posistop Brake should be located as close as possible to the brake. Air lines should be no less than 3/8" diameter minimum. A mounting kit has

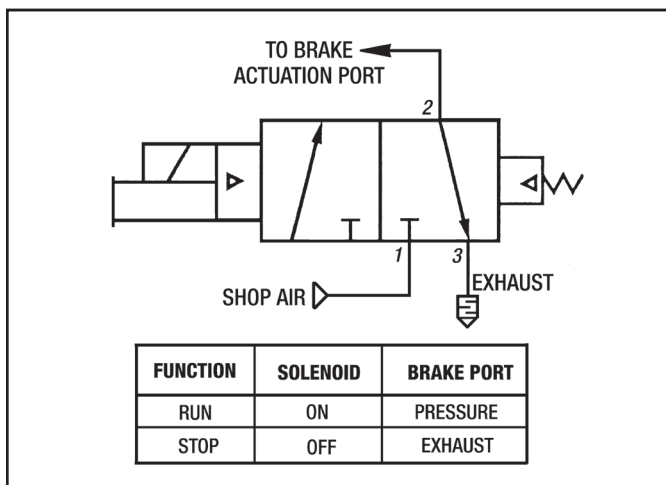

Figure 11 - Control Valve Schematic and Logic

been developed, which is shown in *Figure 8.1* in the complete Service Manual. This Service Manual can be downloaded from our web site:

www.forcecontrol.com

YOUR Posistop MOTOR BRAKE IS NOW READY TO OPERATE.

J. VERTICAL MOUNTING INSTRUCTIONS

VERTICAL MOUNTING (Brake Up)

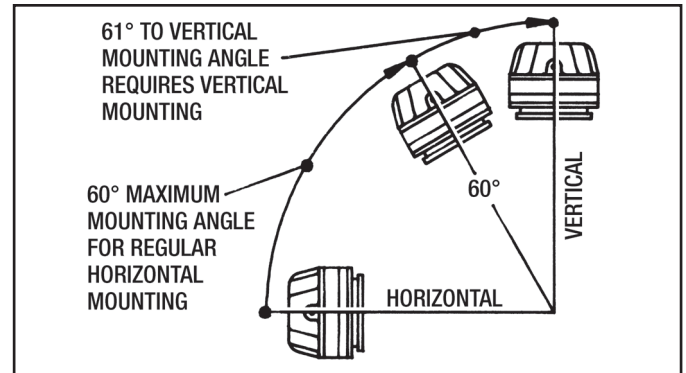

Figure 12 - Mounting Angle (Brake Up)

2. Remove one Pipe Plug (#73) from End Housing (#9) (See *Figure 13*).
3. Remove Air Breather (#45) and Reducing Bushing (#76) from End Housing. (See *Figure 13*)
4. Install Pipe Nipple (#263) in place of Pipe Plug (#73). In the installation of a 250 or 280 motor brake thread Bell Reducer (#262) onto nipple. Or for a 320 motor brake thread Coupling (#256) onto the nipple. Then reinstall Air Breather (#45). (See *Figure 13*)

NOTES

Reducer Bushing (#76) is not used for vertical mounting. Parts (#78), (#79), (#262) and (#263) are furnished in a Vertical Mounting Kit.

Use pipe sealant with Teflon (59241) on all pipe threads.

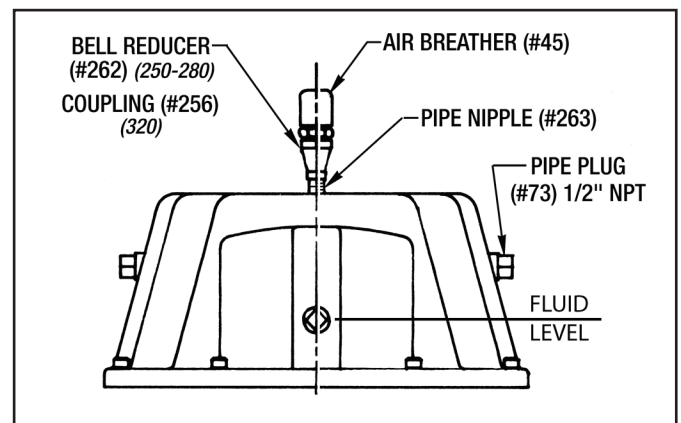

Figure 13 - Air Breather Installation

B. VERTICAL MOUNTING (Brake Down)

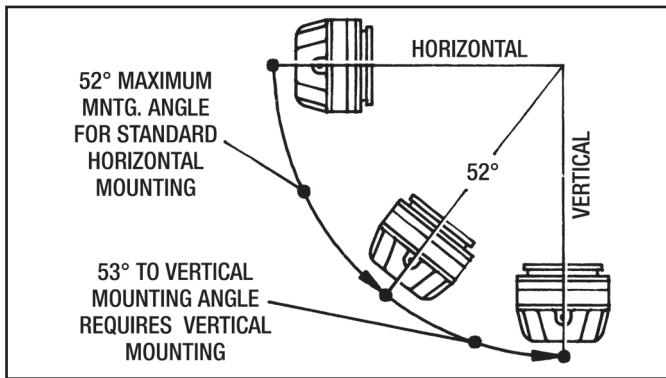

Figure 14 - Mounting Angle (Brake Down)

1. Remove Oil Sight Gauge (#46). (See Figure 15) Install the 1/2" N.P.T. x 2" long Nipple (#254) into hole. Screw Nipple (#253) into Elbow (#259) and screw Cap (#269) onto nipple. Screw this Assembly onto Nipple (#254). (See Figure 15)
2. Remove Nipple (#77) and Pipe Cap (#67) from Housing (#8). Make sure this hole will be on the top

side as the brake goes from vertical to horizontal. Rotate Housing (#8) to achieve this if necessary. (See Figure 15)

3. Install Nipple (#263) along with 45 degree Elbow (#258) and Breather (#266) into the hole in Housing (#8). (See Figure 15)
4. Remove Air Breather (#45) and Reducer Bushing (#76) from End Housing (#9). Install 1/2" N.P.T. Pipe Plug (#267) in the vacated breather hole (See Figure 15) **NOTE:** Reducer Bushing (#76), Air Breather (#45) and Sight Gauge (#46) are not used.

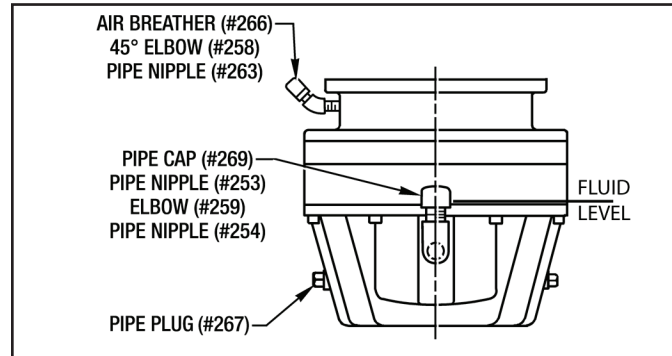

Figure 15 - Air Breather Installation (Brake Down)

LUBRICATION

A. CHECKING THE OIL LEVEL

Check the oil level when the drive is installed and weekly thereafter (until experience dictates otherwise). Always check the oil level with the unit stationary (not running).

NOTE - Oil Gauge (#46) and Pipe Plug (#75) may be reversed so that level is visible from other side

B. CHANGING THE OIL

Every three (3) months remove Drain Plug (#74) and (#64) at the bottom of the End Housing (#9) and Housing (#8). Drain all oil before refilling. More frequent oil change

may be required on high kinetic energy applications or in extremely dirty environments. Check the Oil Sight Gauge (#46) for dirt. Remove and clean if necessary. Replace the drain plugs. Refill unit with clean oil up to the center of the sight gauge. The capacity is as follows:

CAUTION - Do not over fill with oil. Excess oil will cause the unit to overheat

C. TYPE OF OIL

Use Automatic Transmission Fluid, Mobil ATF-210 (type F) only. Always use the type of oil called out on the Name Plate.

FACTORY REBUILD SERVICE & COMPLETE SERVICE MANUAL

A. FACTORY REBUILD SERVICE

A Factory Rebuild Service is offered by Force Control. Contact our service or sales department for additional information.

B. COMPLETE SERVICE MANUAL

A complete Service Manual can be downloaded and printed off of our web site. Go to: www.forcecontrol.com

All of our catalogs and manuals on the web site are in PDF format and will require Adobe Acrobat Reader 5.0 or later to open them. This Adobe Acrobat Reader can be downloaded from our web site if you do not have it installed on your computer.



FORCE CONTROL INDUSTRIES, INC.

3660 Dixie Highway
Fairfield, Ohio 45014

Phone: 513-868-0900
Fax: 513-868-2105

E-Mail: info@forcecontrol.com
Web Site: www.forcecontrol.com

Force Control Industries, Inc.