

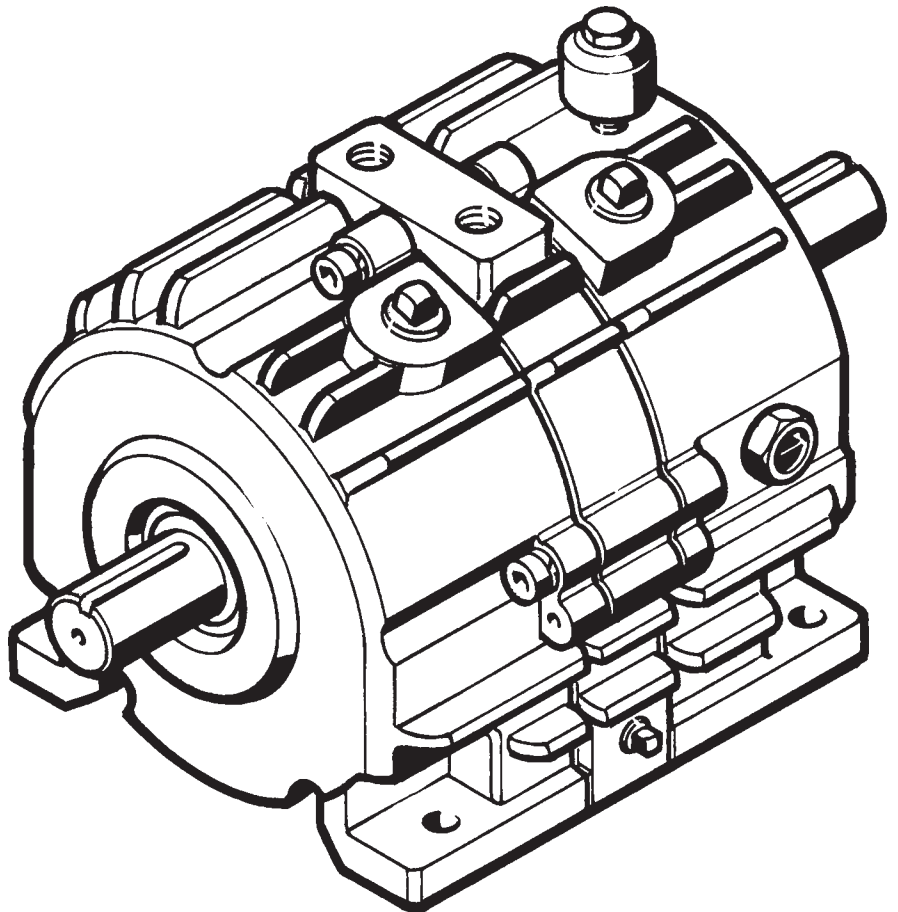

502-02-001-01

SERVICE MANUAL
AND
REPAIR PARTS
FOR
Size 02 *Posidyne*[®]
CLUTCH/BRAKE DRIVES



WARNING - Read this manual before any installation, maintenance and operation.



FORCE CONTROL INDUSTRIES, INC.

**MANUFACTURERS OF MECHANICAL AND
ELECTRICAL POWER TRANSMISSION EQUIPMENT**

Limited Warranty

Upon written approval of the application by Force Control Industries, Inc. the standard warranty period will be extended to 24 months from date of shipment.

Force Control Industries, Inc. ("Force Control") warrants its products to be free from defects in material and workmanship under normal and proper use for a period of one year from the date of shipment. Any products purchased from Force Control that upon inspection at Force Control's factory prove to be defective as a result of normal use during the one year period will be repaired or replaced (at Force Controls' option) without any charge for parts or labor. This limited warranty shall be void in regard to (1) any product or part thereof which has been altered or repaired by a buyer without Force Control's previous written consent or (2) any product or part thereof that has been subjected to unusual electrical, physical or mechanical stress, or upon which the original identification marks have been removed or altered. Transportation charges for shipping any product or part thereof that the buyer claims is covered by this limited warranty shall be paid by the buyer. If Force Control determines that any product or part thereof should be repaired or replaced under the terms of this limited warranty it will pay for shipping the repaired or replaced product or part thereof back to the buyer. EXCEPT FOR THE EXPRESS WARRANTY SET OUT ABOVE, FORCE CONTROL DOES NOT GRANT ANY WARRANTIES EITHER EXPRESSED OR IMPLIED, INCLUDING IMPLIED WARRANTIES OF MERCHANTABILITY OR FITNESS FOR USE. The warranty obligation set forth above is in lieu of all obligations or liabilities of Force Control for any damages. Force Control specifically shall not be liable for any costs incurred by the buyer in disconnecting or re-installing any product or part thereof repaired or replace under the limited warranty set out above. FORCE CONTROL EXPRESSLY EXCLUDES ALL LIABILITY FOR ANY INDIRECT OR CONSEQUENTIAL DAMAGES THE BUYER MAY SUSTAIN IN CONNECTION WITH THE DELIVERY, USE, OR PERFORMANCE OF FORCE CONTROL PRODUCTS. Under no circumstances shall any liability for which Force Control is held responsible exceed the selling price to the buyer of the Force Control products that are proven to be defective. This limited warranty may be modified only in writing signed by a duly authorized officer of the company. This limited warranty applies exclusively to Force Control products; warranties for motors and gear reducers and other component parts may be provided by their respective manufactures. Any legal action for breach of any Force Control warranty must be commenced within one year of the date on which the breach is or should have been discovered.

A Return Goods Authorization (RGA) number must be obtained from the factory and clearly marked on the outside of the package before any equipment will be accepted for warranty work. Force Control will pay the shipping costs of returning the owner parts that are covered by warranty.

Force Control believes that the information in this document is accurate. The document has been carefully reviewed for technical accuracy. In the event that technical or typographical errors exist, Force Control reserves the right to make changes to subsequent editions of this document without prior notice to holders of this edition. The reader should consult Force Control if errors are suspected. In no event shall Force Control be liable for any damages arising out of or related to this document or the information contained in it.



TABLE OF CONTENTS

Section 1 - DESCRIPTION and OPERATION

1-1 The Oil Shear Principle	1
1-2 Description	1
1-3 Operation	1

Section 2 - SPECIFICATIONS

2-1 Model Designations	2
2-2 Specifications	2

Section 3 - INSTALLATION

3-1 Receiving the Drive	2
3-2 Mounting the Drive	2
3-3 Compressed Air Connections	3

Section 4 - LUBRICATION

4-1 Checking the Oil Level	4
4-2 Changing the Oil	4
4-3 Type of Oil	4

Section 5 - OPERATIONAL CHECKS

5-1 General Set-Up Instructions	5
5-2 Checking Clutch/Brake Piston Seals	5
5-3 Checking Clutch/Brake Engagement	5
5-4 Drive Motors	5
5-5 Pneumatic Control	5

Section 6 - TROUBLESHOOTING

6-1 Trouble Shooting Chart	6
----------------------------------	---

Section 7 - DISASSEMBLY

7-1 General Disassembly Procedure	8
7-2 Removing C-Face Mounted Drive Motor and C-Face Flange	8
7-3 Removing Fan Shroud and Fan	8
7-4 Removing Manifold Mounted Control Valve	8
7-5 Separation and Removal of Major Subassemblies for Access to the Clutch/Brake Stacks	8
7-6 Removing Clutch and Brake Stacks	8
7-7 Input Housing Disassembly	9
7-8 Piston Housing Disassembly	9
7-9 Removing Output Shaft Sub-Assembly	10
7-10 Output Shaft Disassembly	10
7-11 Removing Heat Exchanger (#48)	11

Section 8 - CLEANING and INSPECTION

8-1 Cleaning and Inspection	11
8-2 Repair and Replacement	11

Section 9 - REASSEMBLY

9-1 General Reassembly Instructions	12
9-2 Installing Heat Exchanger	12
9-3 Special Assembly Tools	13
A. Oil Seal Assembly Tool	13
B. Wear Sleeve Assembly Tool	13
C. Male Shaft Adapter Puck	13
D. Bearing Assembly Tool	13
9-4 Output Shaft Reassembly	14
A. Installing Bearings	14
B. Installing Wear Sleeve (#195)	14
9-5 Installing Output Shaft Sub-Assembly	14
9-6 Piston Reassembly	15
9-7 Piston Housing Reassembly	15
9-8 Input Shaft Reassembly	16
A. Installing Bearing (#26)	16
B. Installing Wear Sleeve (#195)	16
9-9 Installing Input Shaft Sub-Assembly	17
9-10 Measuring and Controlling Stack Height Dimensions	17
A. Checking Old Stacks for Wear	17
B. Checking and Controlling New Stack Heights	18
9-11 Reassembly of Major Sub-Assemblies and Clutch/Brake Stacks	18
9-12 Fan and Fan Shroud Installation	19
9-13 Attaching C-Face Flange and Drive Motor	19
9-14 Installing Belt Driven Sheave or Pulley	19
9-15 Installing Manifold Mounted Control Valve	19
9-16 Final Reassembly	19

Section 10 - ILLUSTRATED PARTS LIST

10-1 General Information	20
10-2 Drive Motors	20
10-3 Factory Rebuild Service	20
10-4 Ordering Replacement Parts	20
10-5 Name Plate and Model Number Information	20
<i>Posidyne</i> Model Numbers	21

REPAIR PARTS (Subassemblies)

Figure 10.1 - Size 02 <i>Posidyne</i> Clutch/Brake Assembly	23
Figure 10.2 - Quill Input Shaft and Mounting Adapter Flanges	25
Figure 10.3 - Manifold Mounted Control Valves	27
Figure 10.4 - Dimensional Check Chart	28

Section 1

DESCRIPTION AND OPERATION

1-1 THE OIL SHEAR PRINCIPLE

Conventional clutches and brakes depend on the friction between solid surfaces operating in air to transmit torque. Friction does the job, but produces a great amount of heat and wear. The *Posidyne* Clutch/Brake units are oil shear drives, with the friction surfaces operating in a bath of oil. The oil molecules tend to cling to each other, and to the friction surfaces. As moving and stationary elements are brought together, a thin but positive film of oil is maintained between them. The oil film is controlled by a clamping pressure and by carefully designed grooves in the elements. Torque is transmitted from one element to the other through the viscous shear of the oil film. So long as there is relative motion between the elements, they are protected by the oil, thus greatly reducing wear. The oil bath also effectively transmits heat away from the friction elements.

1-2 DESCRIPTION

(See Figure 1.1)

In the *Posidyne* Clutch/Brakes, the friction surfaces consist of alternate carbon steel plates and advanced friction material on steel discs. The oil control grooves are molded into the friction material disc surfaces. The discs have internal teeth which mate with a spline on the output shaft for both clutch and brake applications. The steel plates are keyed to the input shaft in the clutch and to the housing for the brake when used. The splined sections of the *Posidyne* output shaft contain centrifugal impel-

lers to maintain a positive flow of oil between the discs and plates.

As noted in Section 2, Specifications, standard *Posidyne* units may be equipped with a clutch and a brake, or a clutch only. The Clutch is normally operated by compressed air, although hydraulic pressure can be used. The *Posidyne* brake may be pressure operated, or it may be spring loaded to operate automatically when the clutch is released, or a combination of both springs and pressure.

1-3 OPERATION

The *Posidyne* cross-section (Figure 1.1) shows the drive with the Brake engaged. A nominal braking force is provided by springs located in the Piston Housing. Heavier springs are used to provide a greater braking force, when needed. Air Assist (as shown), controlled by external valves, also provides a greater braking force. The drive is normally in the Brake Position. The Brake Drive Plates are pinned to the Output Housing and the Friction Discs are splined to the Output Shaft. The Output Shaft is not able to rotate in this Brake Position.

The Clutch is engaged when the air pressure is exhausted from the Brake Port and applied to the Clutch Port. The Piston moves to compress the Clutch Stack on the Input Shaft. The Clutch Drive Plates are pinned to the Input Shaft and the Friction Discs are splined to the Output Shaft. This allows both shafts to rotate at the same speed.

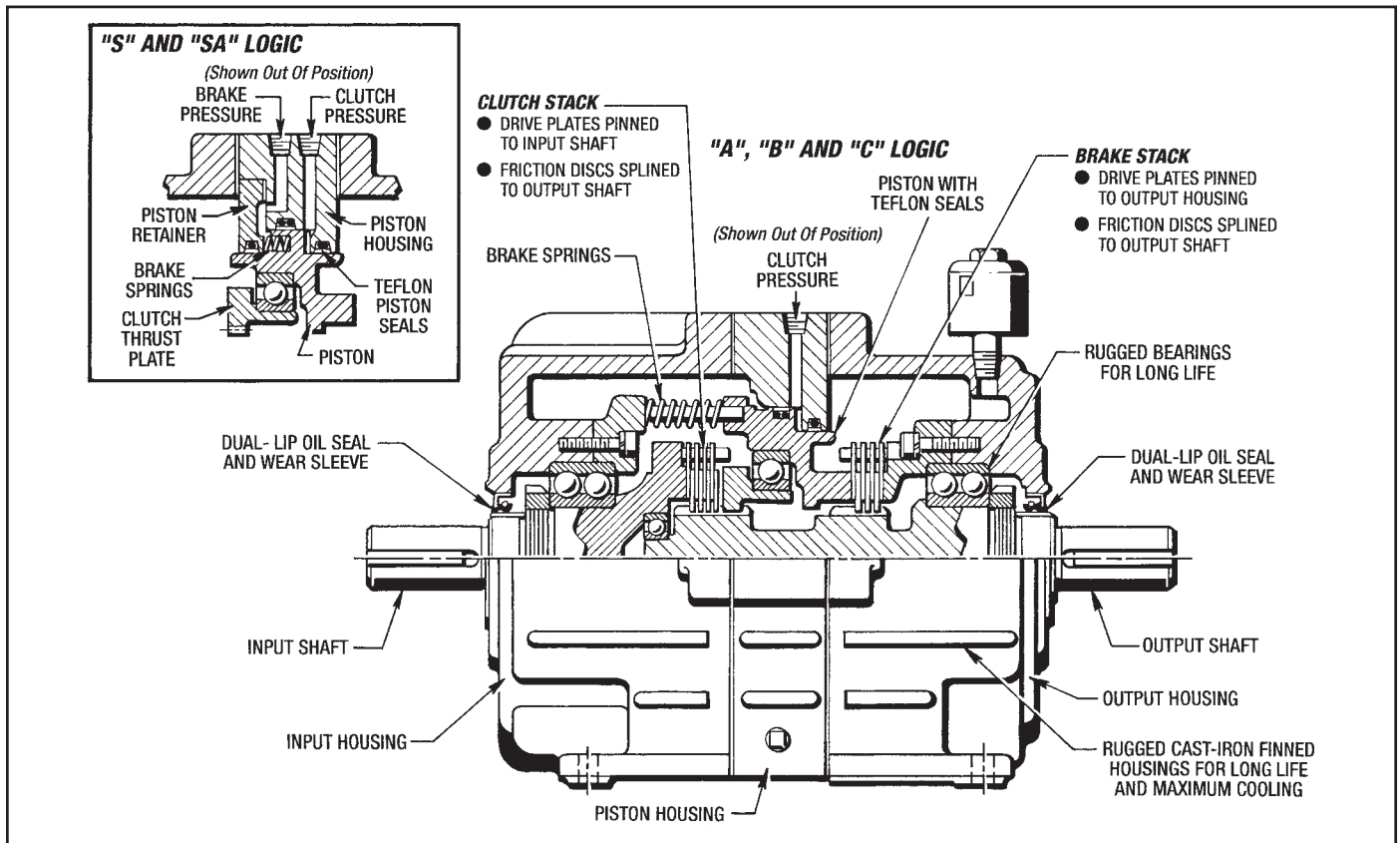

Figure 1.1 - Posidyne Clutch/Brake Drive

Section 2 SPECIFICATIONS (02 Posidyne CLUTCH/BRAKE)

2-1 MODEL DESIGNATIONS

The model designations specifies the size (02) and internal logic type. The types are:

- S** - Air set clutch, light spring set brake with air assist.
- SA** - Air set clutch, medium spring set brake with air assist.
- A** - Pressure actuated clutch, medium spring actuated brake (See NOTE following).
- B** - Pressure actuated clutch, heavy spring actuated brake (See NOTE following).
- C** - Pressure actuated clutch, no brake.

NOTE:

Type A and B units both have spring actuated brakes. The difference is that type B units have additional springs.

2-2 - OPERATING SPECIFICATIONS

Specifications for the 02 Posidyne Clutch/Brake Drives are listed in *Table 2.1*

Torque Ratings

The torque ratings listed are based on maximum actuation pressure as specified in the *Table 2.1*.

Table 2.1 OPERATING SPECIFICATIONS - Size 02 Posidyne Clutch/Brake Units

Size	Logic	Clutch Torque (<i>Lb. In.</i>)		Brake Torque (<i>Lb. In.</i>)				Basic & Fan Cool (<i>RPM</i>)	Water Cool (<i>RPM</i>)	Max. KE per Engmt. (<i>Ft. Lbs.</i>)	Average Thermal HP Cooling*			Air Vol. per Engmt. (<i>In.³</i>)	Oil Cap. (<i>Qts.</i>)	Inertia of Cyclic Parts (<i>Lb. Ft.²</i>)
		Static @ PSIG	Dynamic @ PSIG	Springs Only		With Maximum Air Assist					Basic	Fan	Water **			
				Static	Dyn.	Static	Dynamic									
02	S	445 @ 60	384 @ 60	40	34	472 @ 60	407 @ 60	1800	3600	4,650	Horizontal			1	Horiz. 2 ----- Vert. 3	.03
	SA	368 @ 80	316 @ 80	105	90	332 @ 40	286 @ 40				.80	2.00	4.00			
	A	387 @ 80	333 @ 80	110	95	---	---				-----					
	B	240 @ 80	206 @ 80	220	189	---	---				Vertical					
	C	254 @ 60	218 @ 60	---	---	---	---				.40	1.50	2.00			

NOTES:

* - Ratings based on 1800 RPM operating speed and 70° F ambient temperature. Consult factory with special application details.

** - Cooling water flow requirements in GPM equals .10 X calculated thermal horsepower load.

Section 3 INSTALLATION

3-1 RECEIVING THE DRIVE

Check the drive for shortage or damage immediately after arrival. Prompt reporting to the carrier's agent, with notations made on the freight bill, will expedite satisfactory adjustment by the carrier. When unloading or handling the drive, keep it upright. All Drives are filled with oil, ready to run, when shipped. However, before placing the unit in service or storage, check the oil level to make sure none has spilled out in transit. Add oil if necessary (Refer to Section 4 - Lubrication). If the drive is not to be installed and operated soon after arrival, store it in a clean, dry place having a slow, moderate change in ambient temperature.

3-2 MOUNTING THE DRIVE

Installation of the Drive should be made in much the same manner, and receive the same care for a precision gear reducer. Standard Drives are designed for horizontal operation only.

(Vertical, ceiling and side wall installed units are available.) Note the following precautions when mounting the drive:

1. The Drive should be mounted on a firm, level base or foundation, common with both the driving and driven components.
2. Use SAE Grade 5 Hex Hd. Cap Screws to bolt the drive securely into place. Before tightening down the bolts, check alignment with both the driving and driven machinery, then recheck after tightening.
3. If the input or output shaft is to be directly coupled, use only a flexible coupling (with horsepower service factor 3 to 1) to take care of maximum torque requirements. Make sure that the shafts to be coupled are concentric within 0.005 in. TIR. Check for horizontal, vertical and angular misalignment. Use shims as necessary to correct.

CAUTION:

Do not drive couplings or bushings on shaft.

4. If the Drive is to be connected through a belt, chain or gear drive, locate as close as possible to the housing to minimize overhung loads. Make sure that the sheaves, sprockets or gears are in line and that the shafts are parallel.
5. After the machinery has been in operation for a few hours, make sure that all mounting bolts are tight and recheck the alignment of all components.
6. After machinery has been in operation for 40 hours check the mounting bolts and tighten if necessary.

3-3 COMPRESSED AIR CONNECTIONS

Figures 3.1, 3.2 and 3.3 illustrate typical compressed air systems for the 02 *Posidyne* drives:

Note the following when planning and installing the air system:

1. Use direct acting solenoid air valves or pilot operated valves to give the response speed required. Locate the valves as close as possible to the air inlets on the drive. The valves may be installed directly on the drive if they are supported.
2. Be sure to use valves of at least 1.0 Cv
3. The optional accumulator should be used for quick response, particularly if the air line loss and the nature of the air supply is such that recovery is slow. Size the accumulator to be at least 10 times the air required per engagement (See Table 2.1)
4. The air pressure regulator should be sized and set to provide the required torque. (See Table 2.1)
5. Pressure is directly proportional to torque. Use only the pressure necessary. (The clutch is not a variable speed drive. Do not let it slip for extended periods.) This will give additional life to the Clutch/Brake.
6. After using the drive for a few weeks the acceleration time may increase. Increasing the air pressure will restore the acceleration.

NOTE - See Service Manual #502-CV-001 for complete electrical and pneumatic installation instructions for all pneumatic control valves.

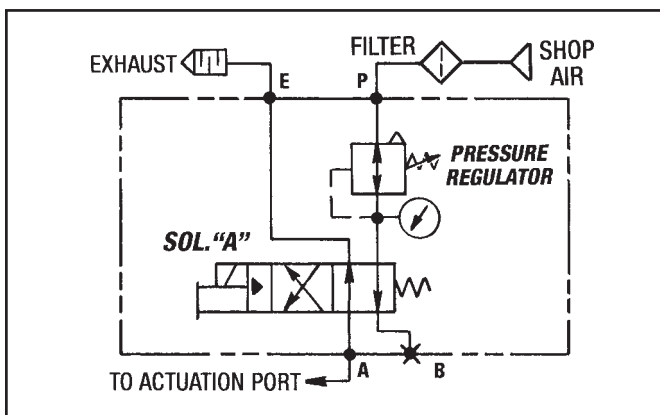

Figure 3.1 - 1PC-3/8 Control Valve with Sandwiched Regulator - Air operated clutch only, spring-set brake. (*Posidyne* A, B and C Logics)

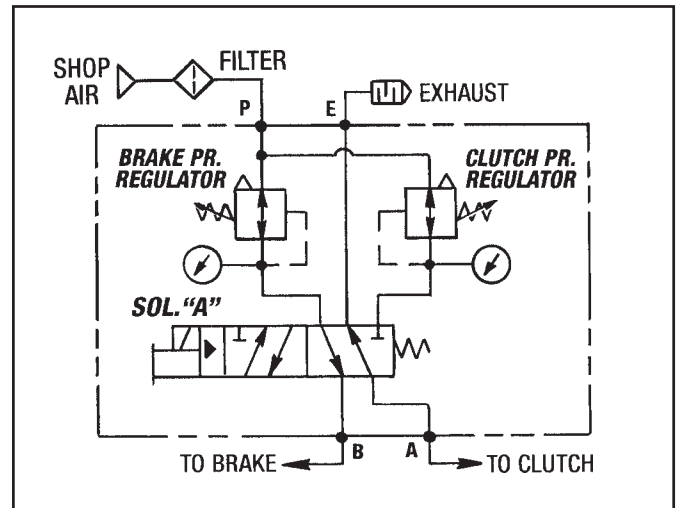

Figure 3.2 - 2PC-3/8 Control Valve with Sandwiched Regulators - Air operated clutch and spring-set brake with air assist. (*Posidyne* S and SA Logics)

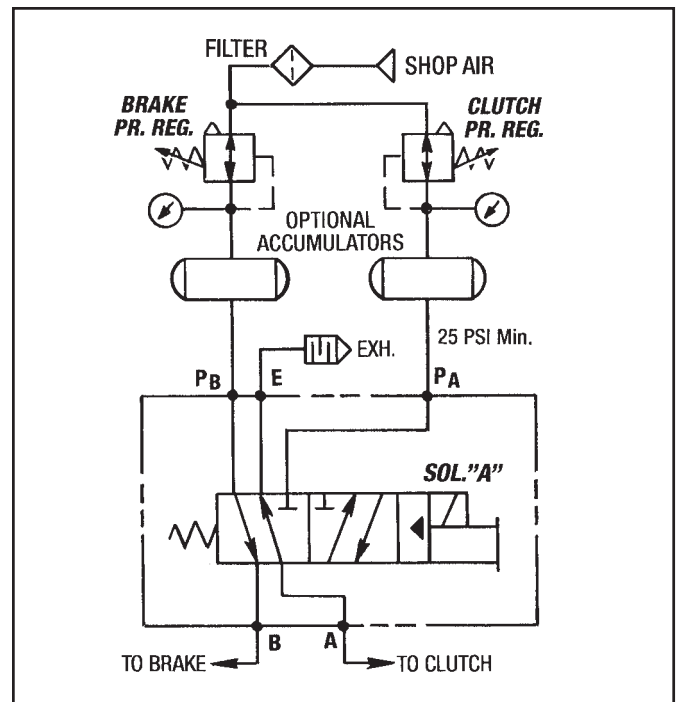

Figure 3.3 - 2PI-3/8 (2-Pressure Inlet) Control Valve without Regulators - Air operated clutch and spring-set brake with air assist. (*Posidyne* S and SA Logics)

Section 4 LUBRICATION

4-1 CHECKING THE OIL LEVEL

When the drive is installed and weekly thereafter, or until experience dictates otherwise, check the oil level. Always check the oil level with the drive at room temperature and while it is not running.

The drive has an Sight Gauge (#46) located in the drive. The oil level is to be at the center of this Sight Gauge with the drive motor turned off. (See *Figure 4.1* for location of the Sight Gauge (#46).)

4-2 CHANGING THE OIL

IMPORTANT - Open the disconnects to the drive motors before attempting to change the oil.

Every three months completely drain the oil from the drive using the drain plugs provided. If the oil sight gauge is dirty, it should be removed and cleaned. (See *Figure 4.1* for location of the drain plugs.)

The Oil Capacity is as follows:

**Horizontal and Wall Mount Installation - 2 Qts.
Vertical Installation - 3 Qts.**

Reinstall the drain plugs and refill the drive to the center of the Sight Gauge (#46) with fresh oil.

CAUTION - Do not overfill the Drive Unit. Excess oil will cause the unit to overheat.

4-3 TYPE OF OIL

Use only **Mobil Automatic Transmission Fluid ATF-210** (type "F") or **Mobil Multi-purpose Automatic Transmission Fluid** for most drives. Other fluids may be specified for special applications. **Always use the type of fluid specified on the Name Plate.**

CAUTION - Use of the wrong type of oil will cause erratic operation, premature wear, damage the unit and void the warranty.

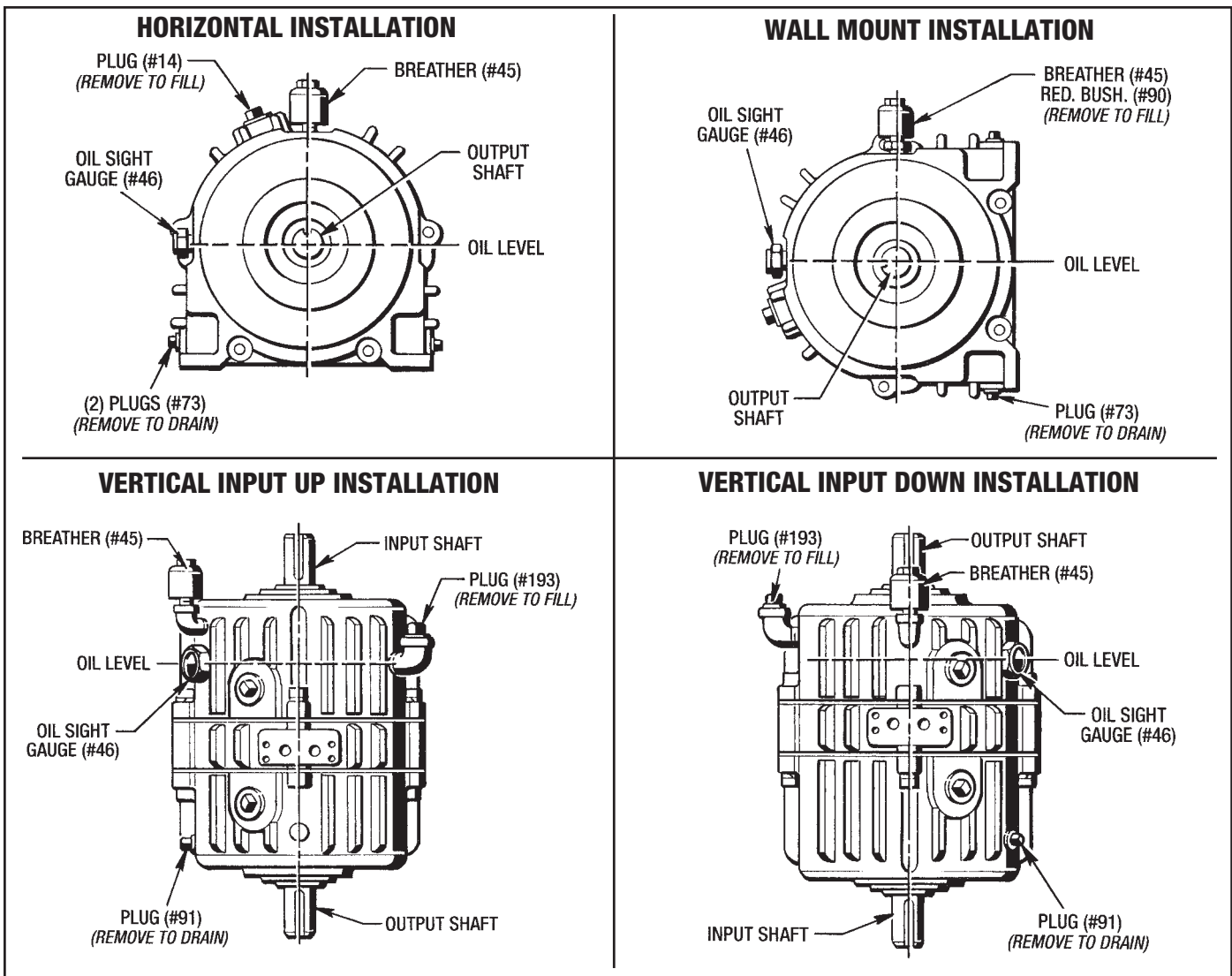

Figure 4.1 - Lubrication

Section 5

OPERATIONAL CHECKS

These Operational Checks are to be made when the Drive Unit is removed from service for repair. Provisions for manually controlled 60 to 80 PSI air pressure must be made for these Operational Checks.

5-1 GENERAL SET-UP INSTRUCTIONS

Assemble a Pneumatic Testing Set-Up similar to the one shown in *Figure 5.1*.

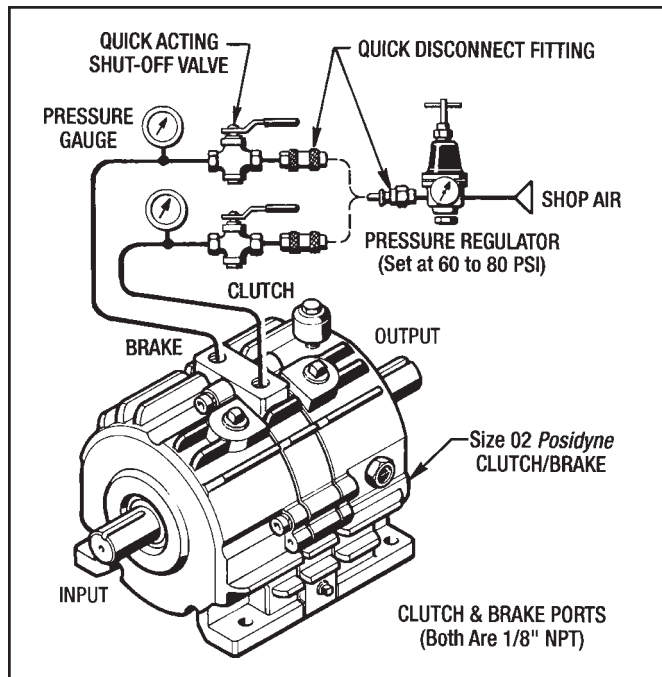

Figure 5.1 - Pneumatic Testing Set-Up for Operational Check

5-2 CHECKING CLUTCH AND BRAKE PISTON SEALS

(See *Figure 5.1*)

1. Connect the Pneumatic Testing Setup to the Clutch Port and apply shop air to it.
2. Crack the Shut-off Valve until the air pressure reads about 80 PSI on the Pressure Gauge and then quickly shut the air off.
3. Observe the Pressure Gauge to see if the air pressure stays the same or drops. If the pressure stays the same or drops slowly, the Piston Seals are okay. If the pressure drops rapidly (more than 5 PSI in 5 seconds), the Piston Seals are leaking and will need to be replaced.
4. Disconnect the shop air and exhaust the air pressure from the drive unit.

(S and SA Logic Only) "Air Assist" to Brake

5. Connect the Pneumatic Testing Setup to the Brake Port and apply shop air to it.
6. Repeat Steps 2, 3 and 4 above.

5-3 CHECKING CLUTCH AND BRAKE ENGAGEMENT OR INPUT SHAFT Vs. OUTPUT SHAFT ROTATION.

(WITH MALE INPUT SHAFTS)

1. When applying air pressure to the Clutch Port, simply rotate the Input Shaft by hand and observe the rotation of the Output Shaft. Likewise, when the air pressure is not applied to the clutch port or when air pressure is applied to the "Air Assist" brake port, the Output Shaft should be locked in the braking position and should not rotate.

(WITH C-FACE MOUNTED DRIVE MOTORS)

If the C-Face mounted Drive Motors are still attached, then the Input Shaft is not accessible to be manually rotated to check Clutch/Brake Engagement and Input Shaft vs. Output Shaft rotation.

1. Temporarily hook-up Drive Motor and "Bump" it to check the Clutch or Brake Operating Modes and Output Shaft rotation.

CAUTION

Do not attempt to run motors with the Inspection Plugs removed. They must first be replaced.

5-4 DRIVE MOTORS

Check wiring connections against the wiring diagram on the Name Plate. "Bump" the motor and check direction of rotation. Check all connections for tightness.

5-5 PNEUMATIC CONTROL

The Pneumatic Control Operational Checks are to be made with Pneumatic Control valves hooked up.

(See *Figures 3.1, 3.2 and 3.3* for appropriate Pneumatic Control Diagram.)

1. Shut off air supply, lock it out, and bleed off any trapped air in the system.
2. Insert Diagnostic Pressure Gauges in the air supply between the control valves and the drive. Turn air supply back on.
3. Activate Solenoid Control Valves for desired function.
 - A. Clutch Drive.
 - B. Brake "Air Assist".
4. Check air pressure with installed diagnostic pressure gauges for each function.
5. Check all electrical connections and the solenoid operation per manufacturer's specifications.

Section 6 TROUBLESHOOTING

6-1 TROUBLESHOOTING CHART

TROUBLE	POSSIBLE CAUSE	REMEDY
Both clutch and brake fail to engage properly.	<p>Electrical control circuit.</p> <p>Low air pressure.</p> <p>Air pressure regulator or piping.</p> <p>Worn friction surfaces.</p>	<p>Check control circuit.</p> <p>Increase air pressure.**</p> <p>Check for improper operation or leaks.</p> <p>Check parts for wear and replace if necessary. (See Section 6-2)</p>
Clutch fails to engage properly.	<p>Electrical control circuit.</p> <p>Valve not functioning properly.</p> <p>Internal air leakage.</p> <p>Low air pressure</p> <p>Worn friction surfaces.</p>	<p>Check control circuit.</p> <p>Check valve operation. Replace if necessary.</p> <p>Check and replace O-Rings and Liners if necessary.</p> <p>Increase air pressure.**</p> <p>Check parts for wear and replace if necessary. (See Section 6-2)</p>
Picks up load too quickly.	<p>Air pressure too high.</p> <p>Low oil level.</p>	<p>Reduce air pressure.</p> <p>Check oil level and add if necessary.</p>
Clutch fails to disengage properly.	<p>Electrical control circuit.</p> <p>Valve not functioning properly.</p> <p>Piston sticking-broken return springs.</p>	<p>Check control circuit.</p> <p>Check and replace valve if necessary.</p> <p>Disassemble to extent necessary and inspect for damaged parts.</p>
Noise and vibration	<p>Mounted on poor foundation.</p> <p>Misaligned couplings.</p> <p>Damaged bearings.</p>	<p>Improve installation. Tighten foot bolts.</p> <p>Recheck alignment.</p> <p>Disassemble to extent necessary and inspect for damaged bearings.</p>
Brake fails to engage properly.	<p>Electrical control circuit.</p> <p>Valve not functioning properly.</p> <p>Internal air leakage.</p> <p>Low air pressure</p> <p>Worn friction surfaces.</p>	<p>Check control circuit.</p> <p>Check valve operation. Replace if necessary.</p> <p>Check and replace O-Rings and Liners if necessary.</p> <p>Increase air pressure.**</p> <p>Check parts for wear and replace if necessary. (See Section 6-2)</p>

TROUBLE	POSSIBLE CAUSE	REMEDY
Brake fails to engage properly. (Continued)	Piston sticking. Weak or broken brake spring.	Disassemble to extent necessary and check for damaged parts. Replace spring.
Brake fails to disengage properly.	Electrical control circuit. Valve not functioning properly. Piston sticking.	Check control circuit. Check and replace valve if necessary. Disassemble to extent necessary and inspect for damaged parts.
Drive overheats. (Oil temp. above 225° F.)	Inertia or resistance changed. Improper oil level. Water turned off. Fan blocked.	Check with Force Control engineering. Check oil level. Add or drain as needed. Check shut-off valve. Clean shroud.
Oil leakage	Oil seal lips damaged. Gaskets Poor ventilation. Seal retainers loose.	Check to see if oil is leaking around shaft and replace if necessary. Tighten all external bolts. Remove breather and clean. Tighten retainer screws.
Oil leakage out breather.	Damaged seal around piston. Oil level too high.	Disassemble and repair. Drain excess oil.
Excessive shaft end play.	Bearings bad.	Disassemble and replace.
Clutch or brake does not repeat.	Air pressure changed. *Oil temperature changed. Resistance in machine changed.	Check air pressure and adjust. Check temperature. Lubricate bearings.

* - For installations requiring precise starting and stopping, operating temperatures are important. Operating temperatures between 116°F and 165°F are recommended. If the oil is allowed to drop to ambient temperatures overnight, the clutch input shaft should be run approximately 1/2 hour before operating the machinery.

** - Max. Air Pressure
S & C Models: 60 PSIG; A & B Models: 80 PSIG; SA Models: 80 PSIG Clutch & 40 PSIG Brake.

Zinc anode - On all water cooled drives, a brass plug containing a zinc anode is installed in the water line close to one of the water connection ports. **DO NOT REMOVE IT.** The zinc anode is installed to prevent electrolysis damage to the oil cooler. Water supply should enter the oil cooler at the port nearest the zinc anode. The zinc anode should be checked occasionally and replaced before it is completely eroded.

Section 7

DISASSEMBLY

7-1 GENERAL DISASSEMBLY PROCEDURE

1. Disconnect the Drive and move it to a suitable work area.

NOTES:

1. On Belt Driven or Direct Coupled Units, remove all necessary safety guards, belts, sheaves and couplings.
 2. For Water Cooled Units, disconnect water inlet and outlet piping. Drain water from the unit.
 3. Disconnect all necessary pneumatic piping.
2. Remove drain plugs at the bottom of the Drive Unit and drain out all of the oil into suitable container and either save for reuse or discard as conditions warrants.
 3. Also remove the Breather (#45) and Sight Gauge (#46) from the Output Housing (#9).

NOTES:

1. We recommend that you set the Drive Unit on the Output End with the Output Shaft in a vertical down position, for ease of disassembly. Supply suitable bracing and clamping to stabilize the Drive Unit for Disassembly.

2. An overhead crane and a soft sling is also recommended, if necessary, to remove heavy castings and parts.

The *Posidyne* Units are comprised of (3) basic subassemblies and can be disassembled as complete subassemblies for easy access to the Clutch/Brake Stacks. The exploded view drawings are as follows:

1. 02 Posidyne CLUTCH/BRAKE ASSEMBLY.
(*Figure 10.1*)
2. QUILL INPUT SHAFT AND C-FACE ADAPTER.
OUTPUT C-FACE ADAPTER AND D-FLANGE
(*Figure 10.2*)
3. MANIFOLD MOUNTED CONTROL VALVE
(*Figure 10.3*)

7-2 REMOVING C-FACE MOUNTED DRIVE MOTOR AND C-FACE FLANGE

(*See Figure 10.2*)

1. Attached appropriate sling to the lifting hook on the Drive Motor for support and removal.
2. Remove the (4) Motor Mounting Screws from the C-Face Adapter (#200).
3. Slide the motor shaft out of the Quill Input Shaft (#2).
4. Remove the (4) Screws (#201) and (4) Lock Washers (#202) and pull the C-Face Flange (#200) off the Input Housing (#8).

7-3 REMOVING FAN SHROUD AND FAN

(*See Figure 10.3*)

1. Remove (2) Screws (#66) from the bottom rear of the Fan Shroud.

2. Pull the Fan Shroud (#24) away from the Input Housing Subassembly.
3. Loosen (2) Set Screws (#70) and remove Fan (#25) from the Input Shaft (#2).
4. Remove both Keys (#180 and #37).

7-4 REMOVING MANIFOLD MOUNTED CONTROL VALVE

(*See Figure 10.3*)

1. Disconnect the Air Hoses and the Brad Harrison Cable.
2. Unscrew (2) Screws (#725) and lift the Control Valve (#700) off the Manifold (#701).
3. Check the (2) O-Rings (#808) and replace if necessary.
4. Remove the Manifold by taking out the (4) Screws (#727) and (4) Lock Washers (#737).
5. Remove Gasket (#807) and discard.

7-5 SEPARATION AND REMOVAL OF MAJOR SUBASSEMBLIES FOR ACCESS TO THE CLUTCH AND BRAKE STACKS

NOTES:

1. Jackscrew holes are provided to aid in the separation of the subassemblies from each other.
2. Do not attempt to reuse the (2) Gaskets (#53). They must be replaced with new ones when reassembled.
3. When removing the Clutch and Brake Stacks, always keep the Drive Plates (#13), Friction Discs (#12) and Shims (#917) in the same order as they were removed.

7-6 REMOVING CLUTCH AND BRAKE STACKS

(*See Figure 10.1*)

1. Remove (5) Soc. Hd. Cap Screws (#69) and (5) Lock Washers (#127) from the input end of the Input Housing Subassembly.
2. Using jackscrews, separate and lift the Input Housing Subassembly away from the Drive Unit.
3. Remove and discard Gasket (#53).
4. The Clutch Stack can now be removed from the Output Shaft Spline.
5. Using jackscrews, separate and lift the Piston Housing Subassembly away from the Output Housing Subassembly.
6. Remove and discard Gasket (#53).
7. The Brake Stack can now be removed from the Output Shaft Spline.

If repair or replacement of the Clutch or Brake Stacks are the only repair to be done, then proceed to **Section 8 - CLEANING AND INSPECTION**.

7-7 INPUT HOUSING DISASSEMBLY

(See Figure 10.1 and 10.2)

The following procedure applies to both the Male Input Shaft and the Quill Input Shaft.

1. If the Key (#180) is still in the Input Shaft (#2), then remove it at this time. Place tape over the Male Input Shaft Keyway.
2. Remove the (4) Screws (#76) and (4) Lock Washers (#127) from the Bearing Retainer (#16).
3. Use a mallet and tap the Input Shaft (#2) out of the Input Housing (#8).

CAUTION - Be very careful not to damage the lip of the Oil Seal (#31) when removing the Input Shaft (#2).

4. Inspect the Oil Seal (#31) and, if necessary, remove it from the Input Housing (#8) with an Arbor Press.
5. Heat up the Locknut (#34) with an acetylene torch and remove it from the Input Shaft (#2). **Only remove this Locknut (#34) if the Bearing (#26) has to be replaced.**

CAUTION - Wear suitable gloves when handling heated parts.

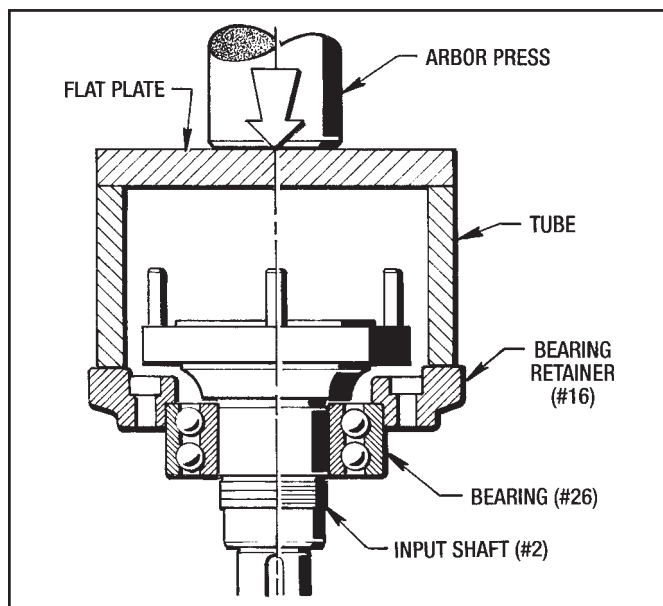

Figure 7.1 - Removing Bearing (#26)

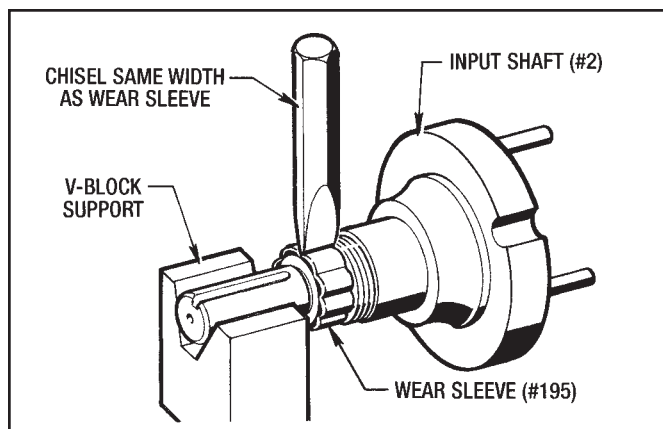

Figure 7.2 - Removing Wear Sleeve (#195)

6. Remove the Bearing Retainer (#16) and Bearing (#26) from the Input Shaft (#2) with an Arbor Press as shown in Figure 7.1.
7. To remove the Wear Sleeve (#195) make about 5 or 6 notches in it with a chisel the same width as the Wear Sleeve as shown in Figure 7.2. The Wear Sleeve (#195) can be removed by hand after this is done.

7-8 PISTON HOUSING DISASSEMBLY

(See Figure 10.1)

(A, B and C Logic)

(See Figure 7.3)

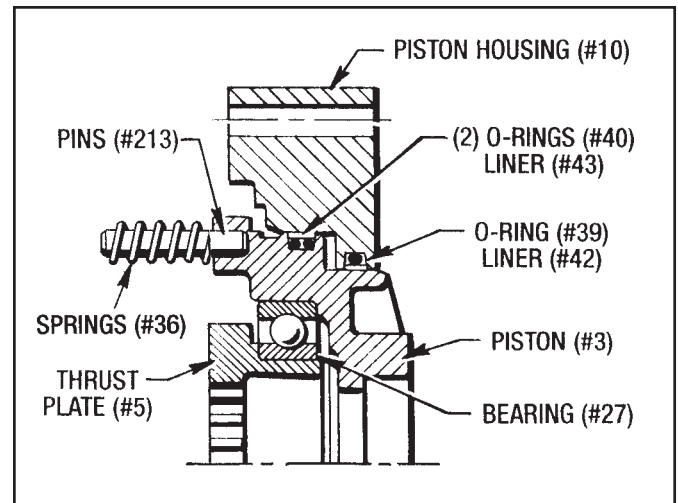

Figure 7.3 - Piston Housing (A, B and C Logic)

1. If the Springs (#36) are still on the Pins (#213), remove them at this time.

NOTE - There will be (4) springs for **A Logic** and **C Logic** and (8) springs for **B Logic**. Make a free-hand sketch of the spring placement. This will help at Reassembly.

2. Remove the Piston Subassembly which consists of: (a) Thrust Plate (#5), (b) Piston (#3), (c) Bearing (#27), (d) Teflon Liner (#43), (e) (2) O-Rings (#40) and (f) Pins (#213).

CAUTION - Be careful not to damage the Piston Liners (#42) and (#43) if they are not to be replaced.

3. Remove the Liner (#43) and (2) O-Rings (#40) from the Piston (#3).
4. Remove the Liner (#42) and O-Ring (#39) from the Piston Housing (#10).
5. Press the Bearing (#27) and Thrust Plate (#5) out of the Piston (#3) with an Arbor Press.

IMPORTANT - Only remove this Bearing (#27) and Thrust Plate (#5) if either one of them has to be replaced.

Do not set the Piston (#3) on the Pins (#213) while pressing the bearing and thrust plate out of the piston. Use an appropriate stand-off spacer under the piston.

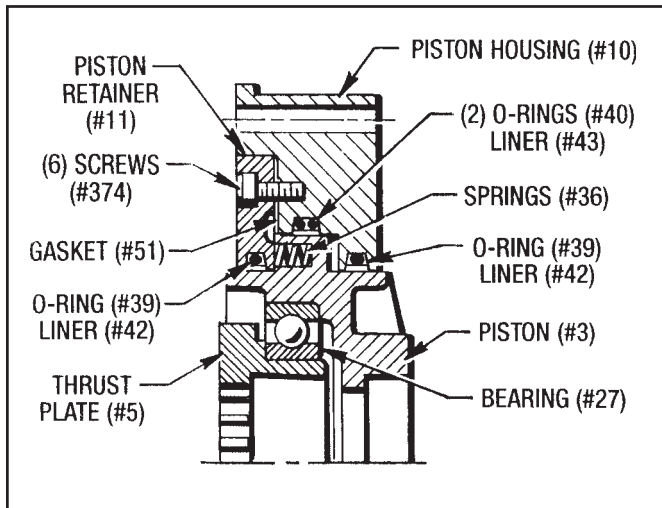

Figure 7.4 - Piston Housing and Retainer (S and SA Logic)

(S and SA Logic)

(See Figure 7.4)

1. Remove the (6) Screws (#374) and take the Piston Retainer (#11) out of the Piston Housing (#10).

CAUTION - This Piston Retainer (#11) is under spring pressure so back these (6) Screws (#374) out in an even manner to avoid the chance of any personal injury.

2. Remove Piston Liner (#42) and O-Ring (#39) from the Piston Retainer (#11).
3. Remove and discard Gasket (#51).
4. Take the Springs (#36) out of the spring pockets.

NOTE - There are (8) Springs for **S Logic** and (24) Springs for **SA Logic**. Make a free-hand sketch of spring placement. This will help at Reassembly.

5. Remove the Piston Subassembly which consists of: (a) Thrust Plate (#5), (b) Piston (#3) and (c) Bearing (#27).

CAUTION - Be careful not to damage the Piston Liner (#42) and Piston Liner (#43) in the Piston Housing (#10) if they are not to be replaced.

6. Remove the Piston Liner (#42), O-Ring (#39), Piston Liner (#43) and (2) O-Rings (#40) from the Piston Housing (#10).
7. Press the Bearing (#27) and Thrust Plate (#5) out of the Piston (#3) with an Arbor Press. If the Bearing (#27) stays in the Piston (#3), use a bar and a mallet to knock it out of the Piston (#3).

IMPORTANT - Only remove this Bearing (#27) and Thrust Plate (#5) if either one of them has to be replaced.

7-9 REMOVING OUTPUT SHAFT SUB-ASSEMBLY

(See Figures 7.5 and 10.1)

1. First, remove the Key (#181) from the Output Shaft (#1) and place tape over the keyway.

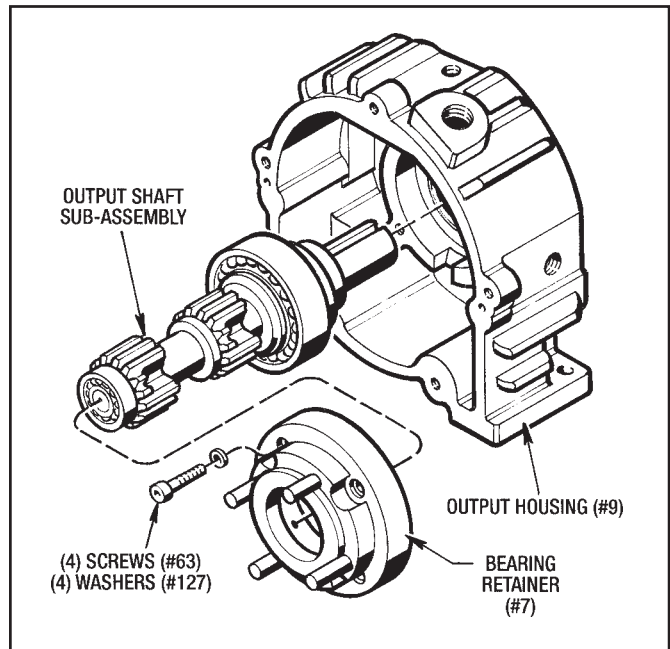

Figure 7.5 - Removing Output Shaft Sub-Assembly

2. Remove the (4) Screws (#63) and (4) Lock Washers (#127) and take the Bearing Retainer (#7) out of the Output Housing (#9).

CAUTION - If your unit has Water Cooling be careful not to damage the Heat Exchanger (#48) when removing the Bearing Retainer or the Output Shaft Sub-Assembly.

3. Tap the Output Shaft Sub-Assembly with a mallet and pull it out the back end of the Output Housing (#9).

CAUTION - Be careful not to damage the lip of the Oil Seal (#31) when removing this Output Shaft Sub-Assembly.

4. If the Oil Seal (#31) needs replaced, then press it out of the Output Housing (#9) with an Arbor Press.

7-10 OUTPUT SHAFT DISASSEMBLY

(See Figure 10.1)

1. Heat up the Locknut (#34) with an acetylene torch to melt the Loctite thread adhesive and take it off the Output Shaft (#1).

CAUTION - Always wear suitable gloves when handling heated parts.

2. Remove Bearing (#26) from the Output Shaft (#1) with a Bearing Puller.
3. If Bearing (#28) has to be replaced, then remove it from the Output Shaft (#1) with a Bearing Splitter.
4. Remove the Wear Sleeve (#195) with the following procedure shown in Figure 7.6.
 - a. Place the Output Shaft (#1) in suitable V-Block Supports.
 - b. Make about 5 or 6 notches in the Wear Sleeve (#195) with a chisel the same width as the wear sleeve.
 - c. Pull the Wear Sleeve (#195) off the Output Shaft (#1) by hand.

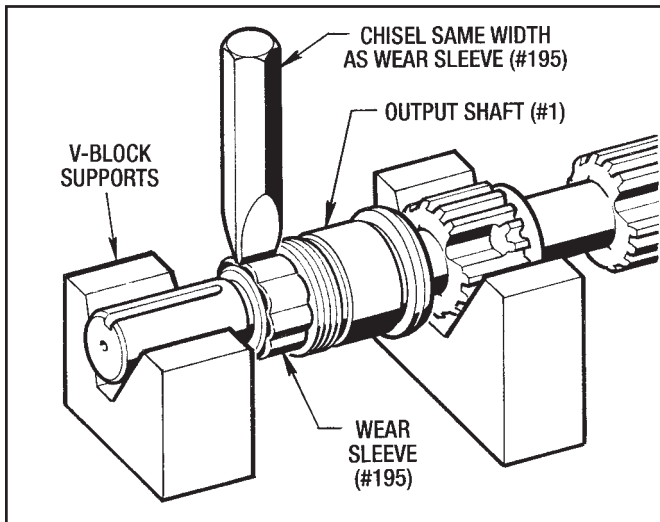

Figure 7.6 - Removing Wear Sleeve (#195)

7-11 REMOVING HEAT EXCHANGER (#48)

(See Figure 7.7 and 10.1)

Only remove this Heat Exchanger if it needs replaced.

1. Remove the Zinc Anode (#176), Tee (#242) and both Compression Fittings (#89).
2. Take a 3/8" Bolt and drive the tubing ends of the Heat Exchanger (#48) out of the Compression Ferrules.
3. Take the (2) Adapter Fittings (#153) out of the Output Housing (#9).

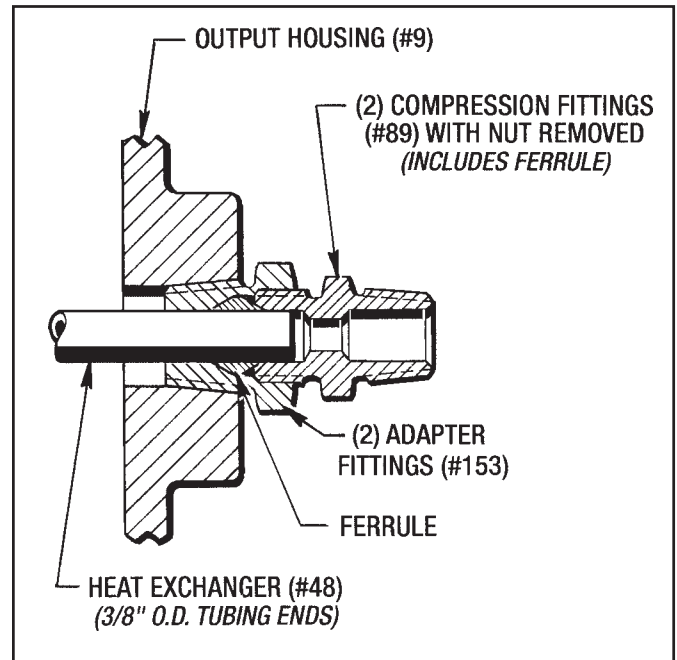

Figure 7.7 - Heat Exchanger Fittings

4. Pull the Heat Exchanger (#48) out of the Output Housing (#9).

Disassembly Procedure is now complete for your Model 02 Posidyne Clutch/Brake Unit.

Section 8 CLEANING and INSPECTION

8-1 CLEANING AND INSPECTION

Clean metal parts in a suitable solvent and dry in a stream of low pressure compressed air. The Drive Plates (#13) and Shims (#917) can be cleaned in a solvent, but DO NOT clean the Friction Discs (#12) in solvent. Use only a clean, dry and lint-free rag to clean these Friction Discs. (Solvent will damage the resilient paper-based friction material used on the Friction Discs). Keep the Drive Plates and Friction Discs in the same order as they were removed. After cleaning, inspect parts for cracks, distortion, scoring, nicks, burrs or other damage would affect serviceability. Pay particular attention to the following:

1. Check the Friction Disc wear surfaces for scoring, galling or evidence of uneven wear.
2. Check the Drive Plates for scoring or galling. Make sure they are flat. If a perceptible ridge is worn in any of the drive plates, replace all of the drive plates and friction discs as a complete set.
3. Carefully check the piston and bore surfaces for nicks, scratches, scoring or other damage which would affect operation or cause leakage.
4. Pay particular attention to the (2) Wear Sleeves (#195) and shafts in the area of rotary seals. Check for nicks, scratches which would cause leakage. Replace any damaged parts.
5. It is not necessary to remove the ball bearings to check their operation. Slowly rotate the free race of each bearing by hand checking to see if it turns freely without rough or flat spots.

8-2 REPAIR AND REPLACEMENT

A fine stone or crocus cloth may be used to remove minor surface defects from parts so long as the operating or sealing action of the part is not affected. The use of coarser abrasives or other machining methods should not be attempted. Otherwise, damaged parts should be replaced.

Replacement is recommended also for the following, as applicable:

1. Replace all O-Rings, Liners, Gaskets and Oil Seals removed during the course of disassembly.
2. Replace Clutch and/or Brake Discs and Drive Plates in complete sets only.

Section 9 REASSEMBLY

9-1 GENERAL REASSEMBLY INSTRUCTIONS

1. Lubricate O-Rings, Liners and the lips of all the Oil Seals with a light coat of "**Mobilith**" **SHC-PM Synthetic Grease**, or equivalent, immediately before Reassembly or Installation of any mating parts. This will be referred to as **White Grease** hereafter in the Reassembly Instructions.
2. The installation of Ball Bearings on to the input and output shafts can be eased by heating the bearings to 250° F. max. and just dropped on. They can also be pressed on to the shafts with an Arbor Press.

CAUTION

Wear suitable gloves when handling heated parts.

3. Use (**Green Loctite #RC-609**), or equivalent, on the I.D. and O.D. of Bearing (#27) when the Piston is reassembled.
4. Apply Gasket Sealant (**Permatex #3D**), or equivalent, to the O.D. of both Oil Seals (#31) when installing them.
5. Spray the Piston Retainer Gasket (#51) with (**K&W Copper Coat #1612S**), or equivalent, before installing it.
6. Do not use any Gasket Sealant on either Housing Gasket (#53).
7. Use Cap Screw Adhesive (**Red Loctite #271**), or equivalent, on all Cap Screws and Locknuts. Use sparingly and clean off any excess with (**Loctite #755**) Adhesive Cleaner. Screws that has Lock Washers does not require any Adhesive.

Basically the Reassembly Procedure is just a reverse order of the Disassembly Procedure described in Section 7.

9-2 INSTALLING HEAT EXCHANGER

(See Figures 9.1 and 10.1)

(Water Cooled Units Only)

1. Pull the tubing ends of the Heat Exchanger (#48) together and insert them into the Output Housing (#9).
2. Slide the (2) Adapter Fittings (#153) over the tubing ends and screw them into the Output Housing (#9). **Use Pipe Dope on the pipe threads.**
3. Visually center the Heat Exchanger coil in the Output Housing (#9) and mark the tubing flush with the ends of each Adapter Fitting (#153). Cut both tubing ends off on your marks with a hacksaw as shown in *Figure 9.1*.
4. Deburr the tubing ends and blow out any shavings.
5. Slide each Ferrule over both tubing ends.
6. Apply a little **Red Loctite #271** to both internal threads of each Adapter Fitting (#153).
7. Place a Warning Tag (#237) over each Compression Fitting (#89) and hand tighten them into each Adapter Fitting (#153). Then tighten them one full turn with a wrench to properly seal them.

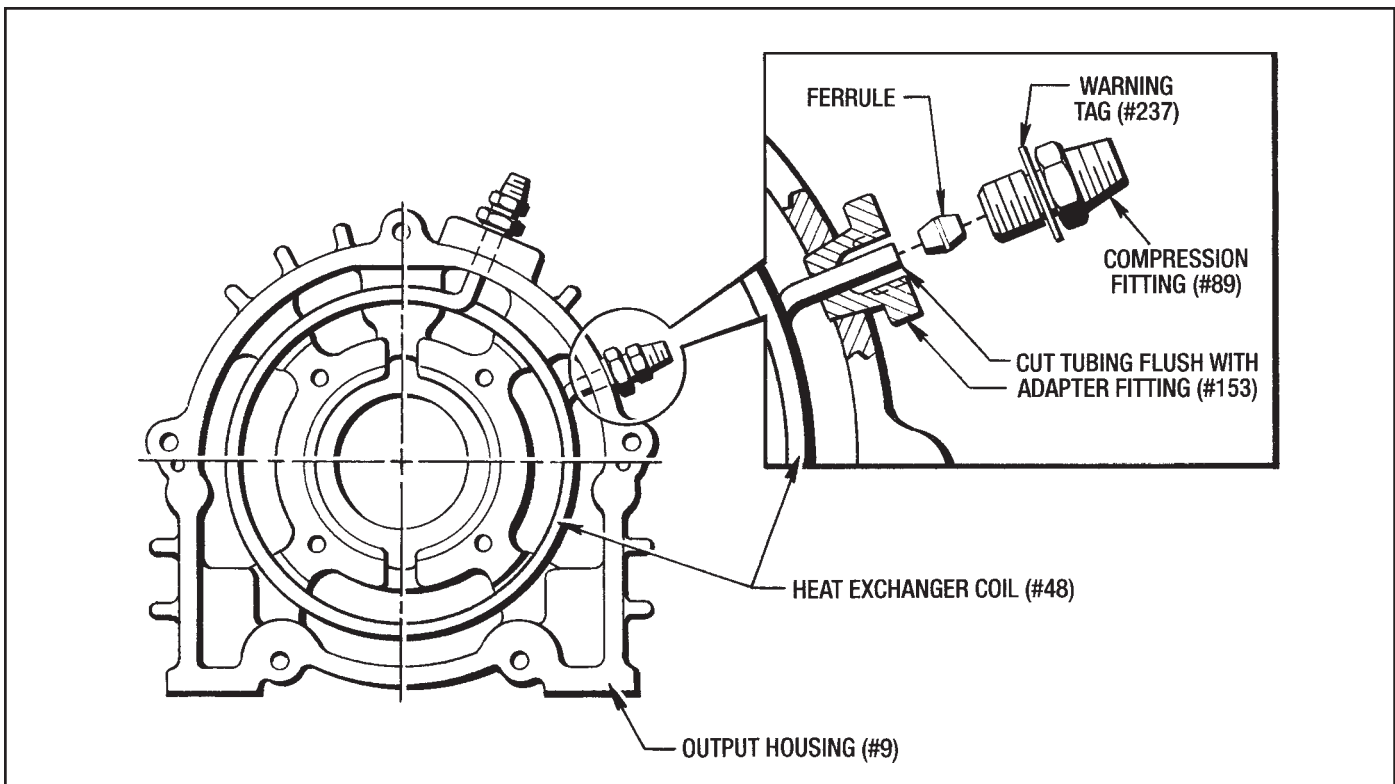

Figure 9.1 - Installing Heat Exchanger (#48)

9-3 SPECIAL ASSEMBLY TOOLS

Dimensions are given for each Assembly Tool so that you may choose to make your own tools, or they can be ordered from Force Control with the individual Part Numbers.

A. Oil Seal Assembly Tool

(Order with Part Number - #601-02-012)

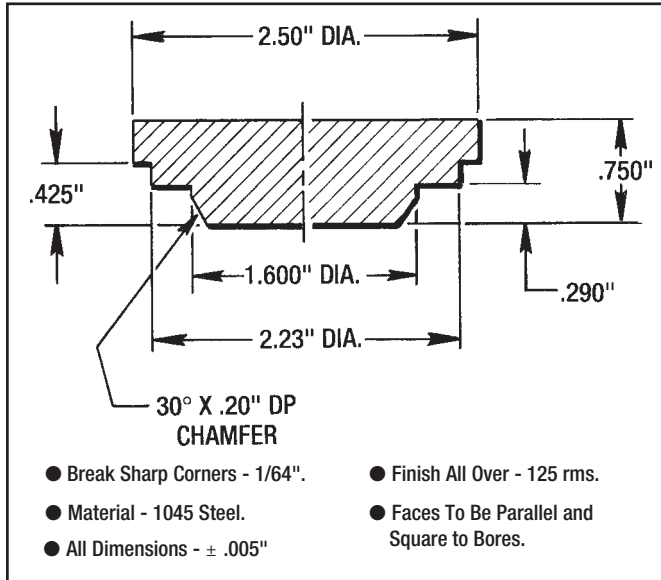

Figure 9.2 - Oil Seal Assembly Tool

B. Wear Sleeve Assembly Tool

(Order with Part Number - #601-02-013)

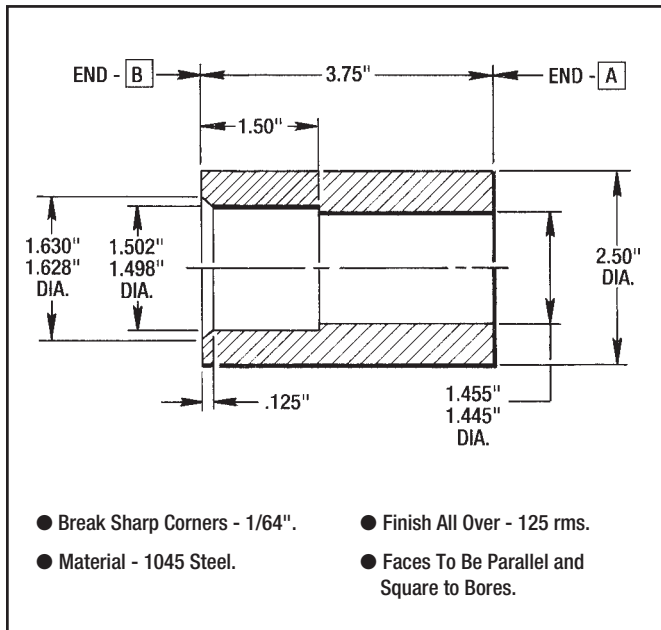

Figure 9.3 - Wear Sleeve Assembly Tool

C. Male Shaft Adapter Puck

(Order with Part Number - #601-02-014)

Specify Shaft Diameter Size when ordering this tool.

This Male Shaft Adapter Puck is used in conjunction with the Wear Sleeve Assembly Tool #601-02-013 shown in Figure 9.3.

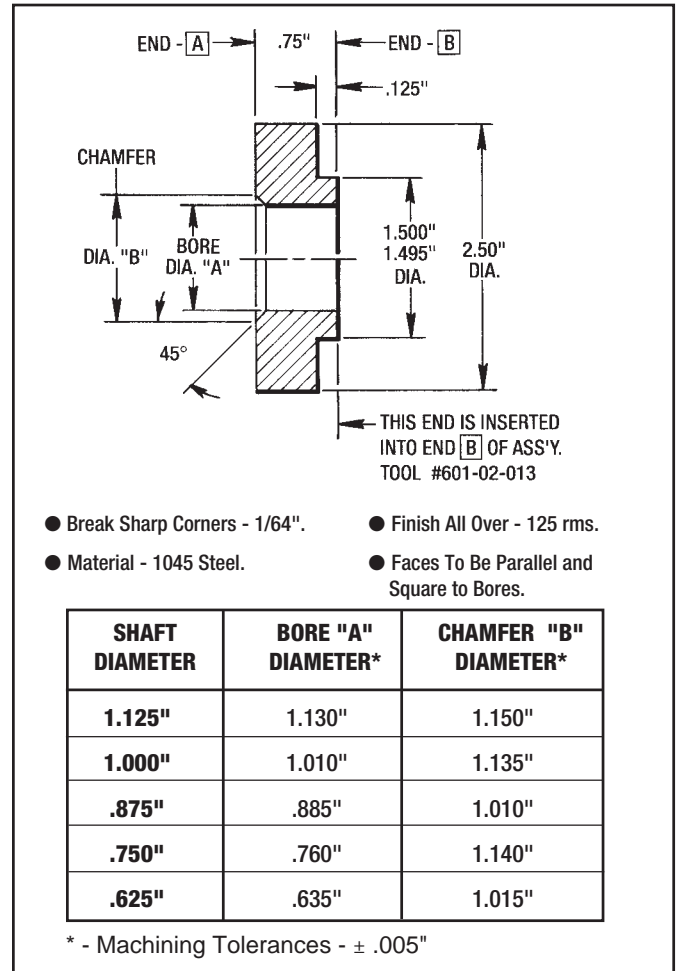

Figure 9.4 - Male Shaft Adapter Puck

D. Bearing Assembly Tool

(Order with Part Number - #601-02-010)

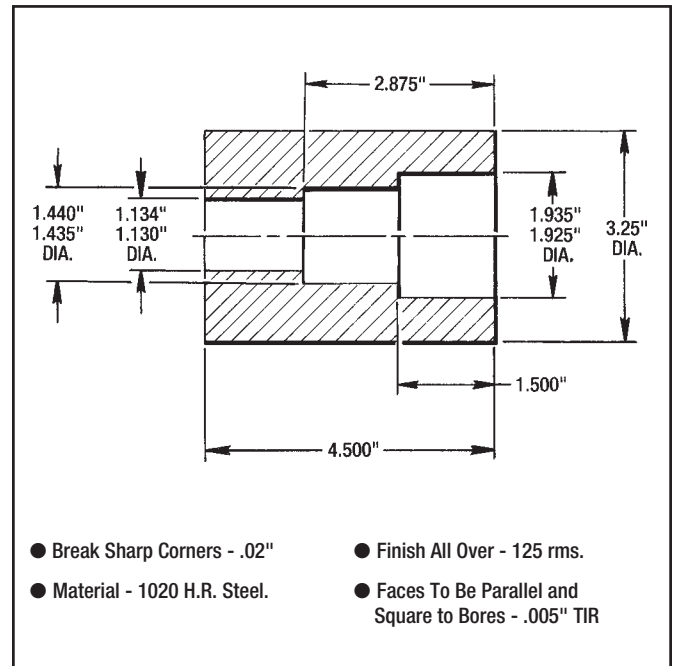

Figure 9.5 - Bearing Assembly Tool

9-4 OUTPUT SHAFT REASSEMBLY

(See Figure 10.1)

A. Installing Bearings

(See Figure 9.6)

1. First install the small Bearing (#28) on to the Output Shaft (#1) with a flat plate and arbor press as shown in Figure 9.6.
2. Then install the larger Bearing (#26) on to the other end of the Output Shaft with the Bearing Assembly Tool #601-02-010 and an arbor press as shown in Figure 9.6.

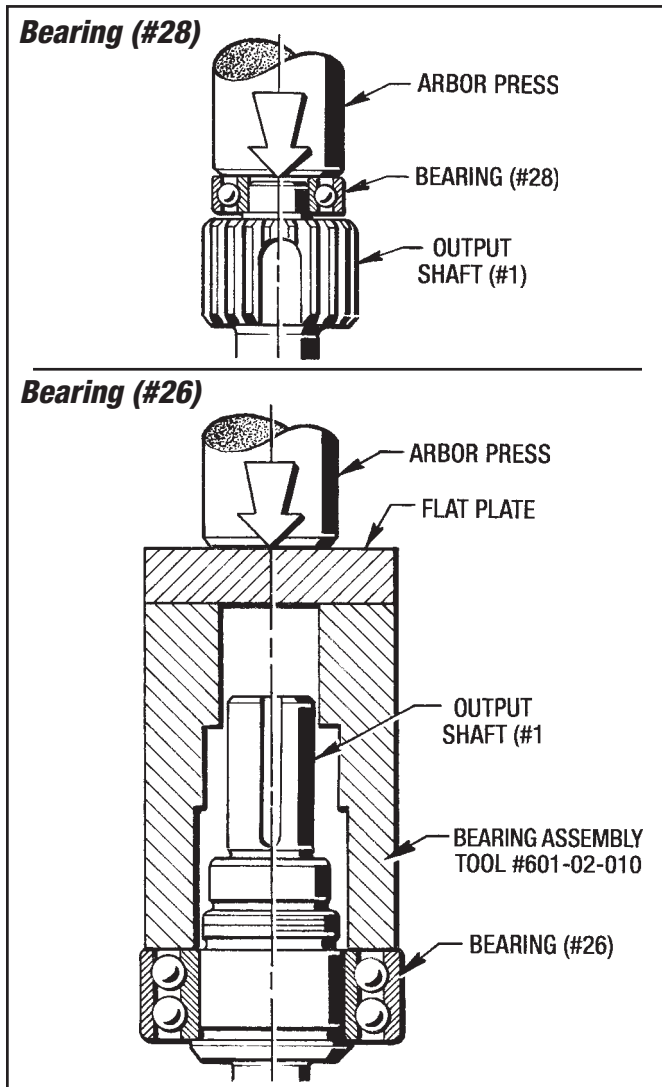

Figure 9.6 - Installing Bearings on the Output Shaft (#1)

3. Apply a little **Red Loctite #271** to the output shaft threads and install the Locknut (#34).

B. Installing Wear Sleeve (#195)

(See Figure 9.7)

Step 1 - Apply a little **Red Loctite #271** to the output shaft. Place the Wear Sleeve (#195) then the Male Shaft Adapter Puck #601-02-014 with **End "A"** pointed down on to the Output Shaft.

Then seat the Assembly Tool #601-02-013 on the Adapter Puck.

Press down with an arbor press as far as the Wear Sleeve (#195) will go.

Step 2 - Remove the Male Shaft Adapter Puck #601-02-014 and replace the Assembly Tool #601-02-013 with **End "B"** pointed down.

Finish pressing the Wear Sleeve (#195) until it is completely seated on the Output Shaft (#1). Clean off any excess Loctite.

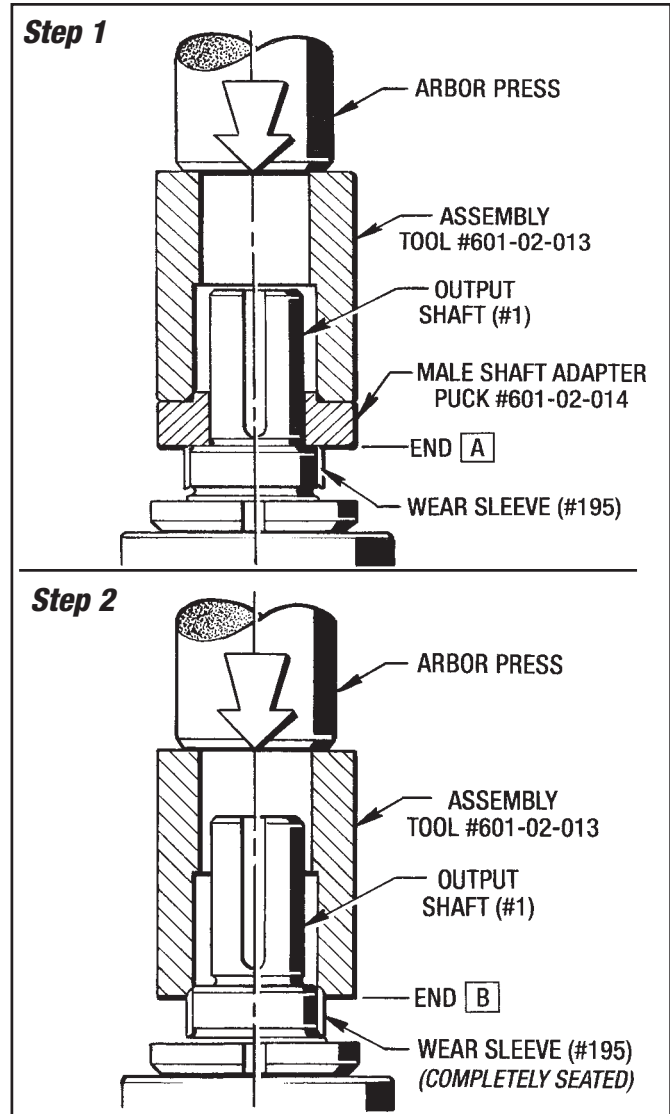

Figure 9.7 - Installing Wear Sleeve (#195)

9-5 INSTALLING OUTPUT SHAFT SUBASSEMBLY

(See Figures 9.8, 9.9 and 10.1)

1. Apply some Permatex #30 Gasket Sealant to the bore and press the Oil Seal (#31) in to the Output Housing (#9) with the Assembly Tool #601-02-012 as shown in Figure 9.8.

NOTE - If you do not use this Assembly Tool, then the Oil Seal (#31) must be pressed into the Output Housing (#9) $1/8$ " from the face of the housing.

2. Lubricate the oil seal lip with **White Grease** and Insert the Output Shaft Sub-assembly into the Output Housing (#9) as shown in Figure 9.9.

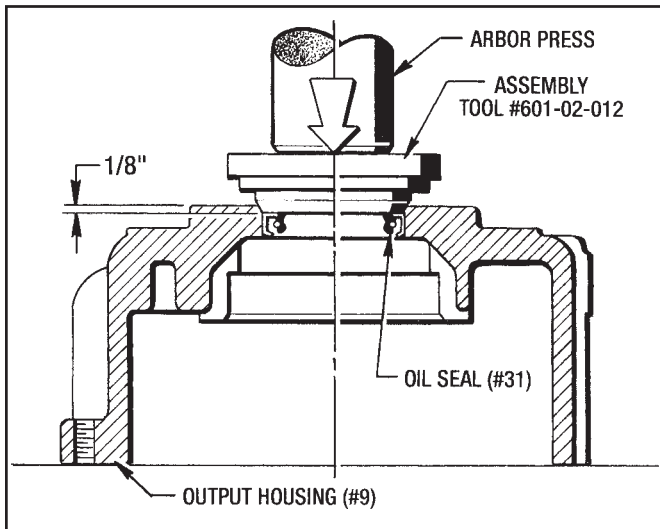

Figure 9.8 - Installing Oil Seal (#31) Into Output Housing (#9)

CAUTION -Be very careful not to damage the lip of the Oil seal (#31) when installing the Output Shaft (#1) into the Output Housing (#9).

3. Make sure the (4) Dowel Pins (#122) are installed **tightly** into the Bearing Retainer (#7). If they are not, apply some **Green Loctite #RC-609** to the (4) holes and drive (4) new Pins (#122) into the Bearing Retainer (#7). Clean off any excess Loctite.
4. Slide the Bearing Retainer (#7) over the Output Shaft (#1) and attach it to the Output Housing (#9) with (4) Screws (#63) and (4) Lock Washers (#127). **Torque to 14 Ft. Lbs.**

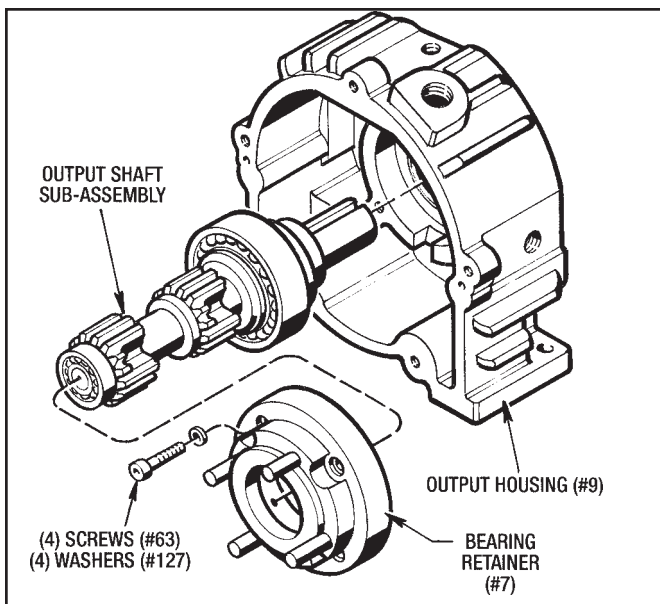

Figure 9.9 - Installing Output Shaft Sub-Assembly

9-6 PISTON REASSEMBLY

(See Figure 10.1)

1. Apply some **Green Loctite #RC-609**, or equivalent, to the O.D. of Bearing (#27) and install it into the Piston (#3) with an Arbor Press until it is completely seated into the Piston (#3). Clean off any excess adhesive.

CAUTION - Do not press on the inner race of the Bearing (#27) when installing it into the Piston (#3). Only press on the outer race.

2. Then apply the **Green Loctite** to the inner race of the bearing and press the Thrust Plate (#5) into the Bearing (#27) until it is completely seated. Clean off any excess adhesive.

("A", "B" and "C" Logics Only)

If the Spring Pins (#213) were removed at Disassembly they will have to be installed into the Piston (#3) at this time.

3. Apply **Red Loctite #271** to the appropriate number of holes in the Piston (#3) and install an appropriate number of Pins (#213) into the holes. There are (4) Pins for "A" and "C" Logic and for "B" Logic there are (8) Pins. (See Figure 9.10) Clean off any excess adhesive.

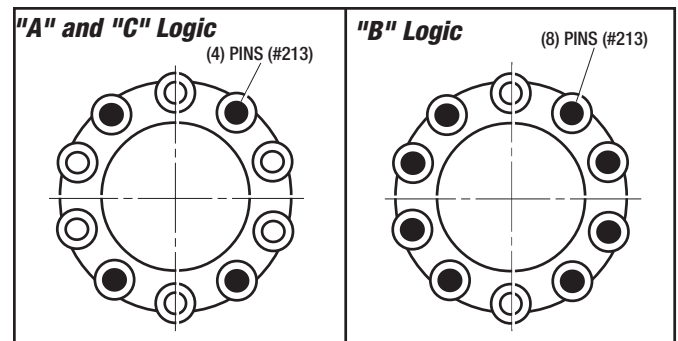

Figure 9.10 - Installing Pins (#213) into Piston (#3)

9-7 PISTON HOUSING REASSEMBLY

(See Figures 9.11 and 10.1)

("A", "B" and "C" Logic)

1. Lubricate the (2) O-Rings (#40) and Piston Liner (#43) with **White Grease** and install them on the Piston (#3).
2. Lubricate the O-Ring (#39) and Piston Liner (#42) with **White Grease** and install them into the Piston Housing (#10).
3. Carefully insert the Piston (#3) into the Piston Housing (#10).

CAUTION - Be very careful not to damage the Piston Liners when installing the Piston (#3) into the Piston Housing (#10).

("S" and "SA" Logic)

1. Lubricate all the O-Rings and Piston Liners with **White Grease**.
2. Install (1) O-Ring (#39) and (1) Piston Liner (#42) into the Piston Housing (#10). Then install (2) O-Rings (#40) and (1) Piston Liner (#43) into the Piston Housing (#10).
3. Install an O-Ring (#39) and a Piston Liner (#42) into the Piston Retainer (#11).
4. Carefully insert the Piston (#3) into the Piston Housing (#10).

CAUTION - Be very careful not to damage the Piston Liners when installing the Piston (#3) into the Piston Housing (#10).

5. Lay the Piston and Piston Housing Sub-Assembly down flat and place the correct number of Springs (#36) into the spring pockets in the Piston (#3).

NOTE - There are (8) pockets and (8) Springs (#36) for the "S" Logic. There are (24) pockets and (24) Springs (#36) for the "SA" Logic Units

6. Spray **K & W Copper Coat**, or equivalent, to both sides of the Gasket (#51) and place it in the Piston Housing (#10).
7. Attach the Piston Retainer (#11) to the Piston Housing (#10) with (6) Screws (#374). **Torque to 7 Ft. Lbs.**

NOTE - Tighten these (6) Screws (#374) down in an even manner to correctly compress the Springs (#36).

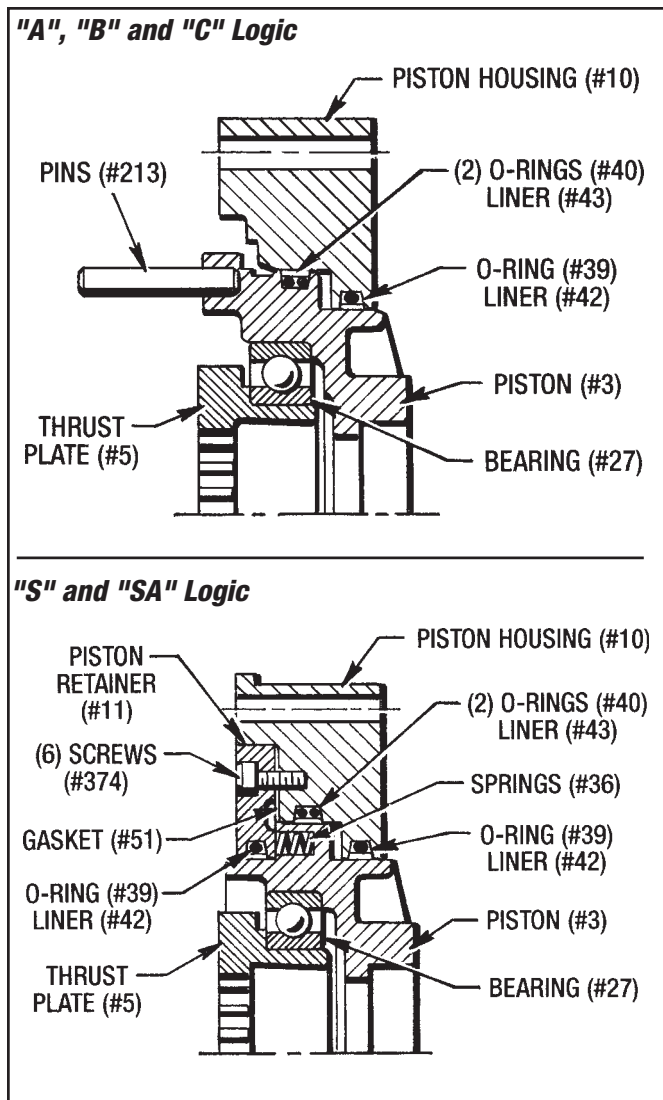

Figure 9.11 - Piston Housing Reassembly

9-8 INPUT SHAFT REASSEMBLY

(See Figure 10.1 and 10.2)

A. Installing Bearing (#26)

(Male and Quill Input Shaft)

1. Place the Bearing Retainer (#16) over the Input Shaft (#2).
2. Press the Bearing (#26) on to the Input Shaft (#2) with the Bearing Assembly Tool #601-02-010 and an Arbor Press until it bottoms out on the shoulder. (See Figure 9.12)

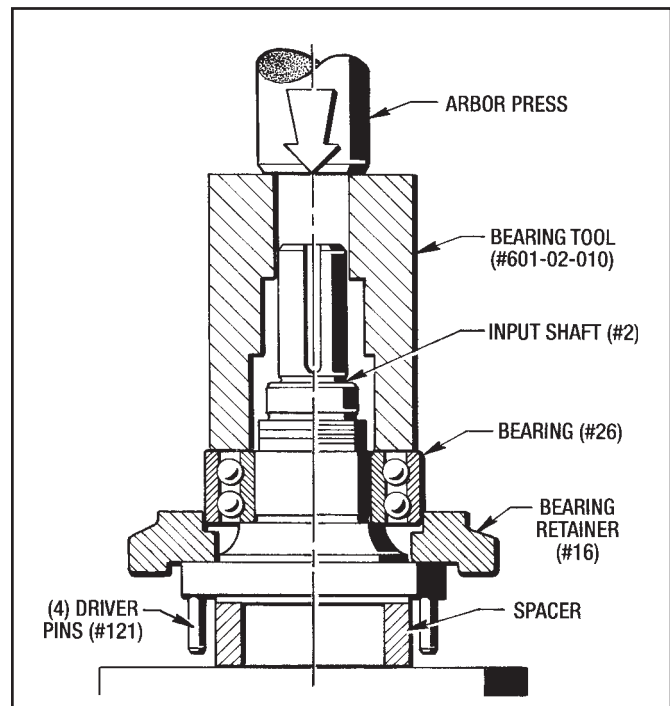

Figure 9.12 - Installing Bearing (#26) on Input Shaft (#2)

CAUTION - If the (4) Driver Pins (#121) are still installed in the Input Shaft (#2), put a spacer under the Input Shaft so you don't press on these (4) pins.

3. Apply some Red Loctite #271 to the threads and install the Locknut (#34) on to the Input Shaft (#2). Clean off any excess adhesive.

B. Installing Wear Sleeve (#195)

(See Figure 10.1 and 10.2)

(Male Input Shaft)

The Installation Procedure is exactly the same as described in Section B of 9-4 Installing Wear Sleeve (#195) on the Output Shaft. (See Figure 9.7)

(Quill Input Shaft)

Only the Wear Sleeve Assembly Tool #601-02-013 is needed to install the Wear Sleeve (#195) on the Quill Input Shaft (#2). The Adapter Puck #601-02-014 is not used.

Place the Quill Input Shaft (#2) into an Arbor Press. If the (4) Driver Pins (#121) are installed in the Input Shaft, place a spacer under the Input Shaft so you don't press on these (4) Pins.

Step 1 - Apply some Red Loctite #271 to the Quill Input Shaft surface.

Place the Wear Sleeve (#195) then the Assembly Tool #601-02-013 with End "A" pointed down over the Quill Input Shaft (#2) as shown in Figure 9.13.

Press the Wear Sleeve (#195) on as far as it will go.

Step 2 - Turn the Assembly Tool #601-02-013 over and with End "B" finish pressing the Wear Sleeve (#195) until it is completely seated on the Input shaft as shown in Figure 9.13. Clean off any excess Loctite.

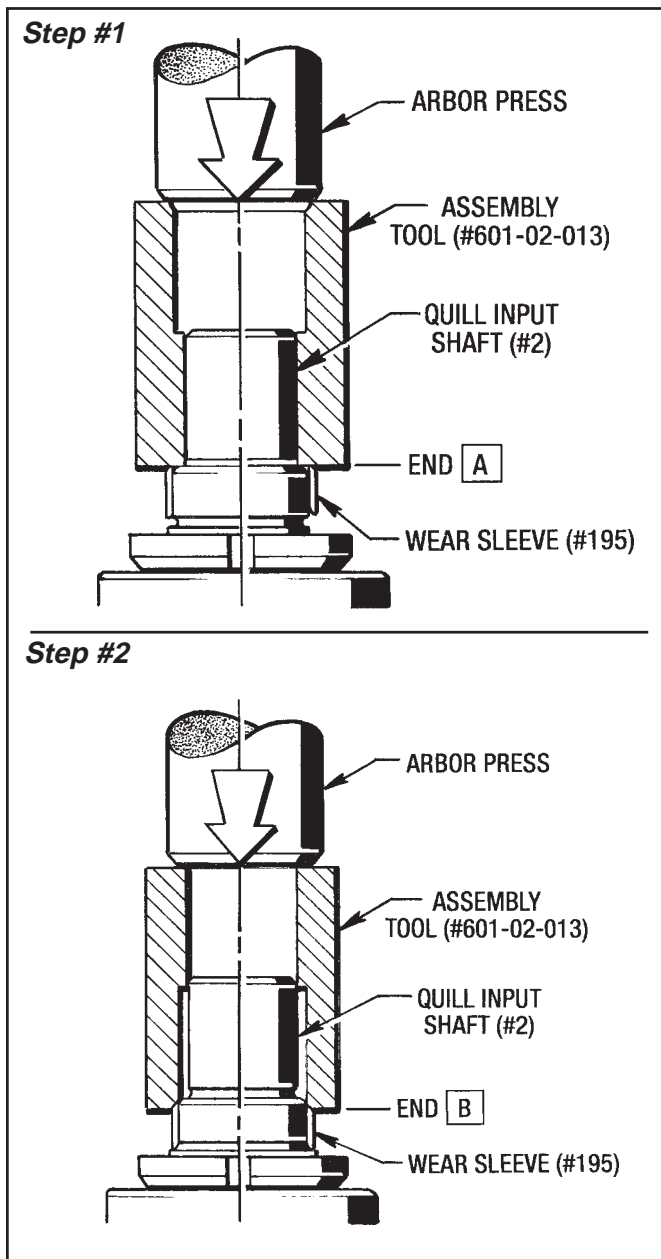

Figure 9.13 - Installing Wear Sleeve (#195) on Quill Input Shaft
(Male and Quill Input Shaft)

If the (4) Driver Pins (#121) are not installed in the Input Shaft (#2), it should be done at this time. Apply some **Green Loctite #RC-609** to each Pin (#121) and drive them in. Clean off any excess Loctite.

IMPORTANT - Make sure that all (4) of the Pins (#121) fit tight and snug in the Input Shaft (#2) If they don't, you will have to replace the whole Input Shaft (#2).

9-9 INSTALLING INPUT SHAFT SUB-ASSEMBLY

(See Figures 10.1 and 10.2)

1. Apply some Permatex #3D Sealant to the bore and press the Oil seal (#31) into the Input Housing (#8) with the Assembly

Tool #601-02-012. This procedure is the same as shown in Figure 9.8 for the output housing. Clean off any excess Sealant.

2. Lubricate the lip of Oil Seal (#31) with White Grease insert the Input Shaft Sub-Assembly into the Input Housing.

CAUTION - Be very careful not to damage the oil seal lip when inserting this Input Shaft Sub-Assembly into the Input Housing.

3. Attach the Bearing Retainer (#16) with (4) Screws (#76) and (4) Lockwashers (#127). **Torque to 14 Ft. Lbs.**

9-10 MEASURING AND CONTROLLING STACK HEIGHT DIMENSIONS

(See Figure 9.14)

To assure correct piston travel and stack engagement, the following steps must be taken when replacing the Clutch and Brake Stacks.

This procedure is also used to determine whether or not your old stack is worn enough to be replaced with new stacks.

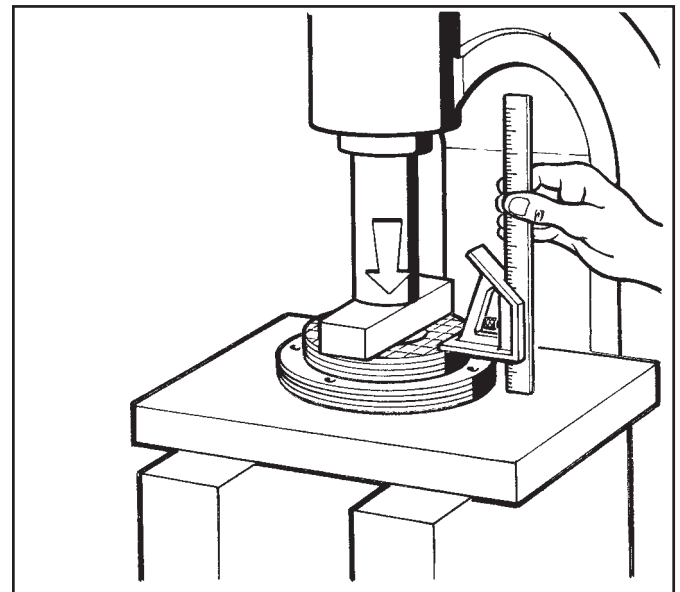

Figure 9.14 - Measuring Stack Heights

A. Checking Old Stacks for Wear

Always measure each individual stack separately.

Measuring the Clutch Stack

1. Place the Clutch Stack in an arbor press as shown in Figure 9.14.
2. Clamp firmly and measure the Clutch Stack Height.

If the Clutch Stack measures **.507"** or less for A, B and C Logic units the Clutch Stack needs replaced.

If the Clutch Stack measures **.523"** or less for S and SA Logic units the Clutch Stack needs replaced.

Measuring the Brake Stack

1. Place the Brake Stack in an arbor press as shown in Figure 9.14.

2. Clamp firmly and measure the Brake Stack Height.

If the Brake Stack measures **.417"** or less it needs to be replaced.

WORN STACK CONDITION

CLUTCH	A, B and C Logics	.507"
	S and SA Logics	.523"
BRAKE	A, B, S and SA Logics	.417"

B. Checking and Controlling New Stack Heights

(See Figure 9.14)

Measuring a New Clutch Stack

1. Place the New Clutch Stack in an arbor press as shown in Figure 9.14.

2. Clamp firmly and measure the New Clutch Stack Height.

If the New Clutch Stack measures **.576"** or less, add (1) **.020"** thick Shim (#917) to the Clutch Stack.

Measuring a New Brake Stack

1. Place the New Brake Stack in an arbor press as shown in Figure 9.14.

2. Clamp firmly and measure the New Brake Stack Height.

If the Brake Stack measures **.476"** or less, add (1) **.020"** thick Shim (#917) to the Brake Stack.

NEW STACK HEIGHTS

STACK	UNCORRECTED HEIGHT		CORRECTED HEIGHT	
	MIN.	MAX.	MIN.	MAX.
CLUTCH	.548"	.596"	.568"	.596"
BRAKE	.456"	.496"	.476"	.496"

IMPORTANT - Never exceed the Maximum Corrected Height for either stack. To do so would take up the necessary "Running Clearance".

NOTE - If a Shim (#917) is required, always place it at the opposite end of the Piston (#3).

9-11 REASSEMBLY OF MAJOR SUB-ASSEMBLIES AND CLUTCH / BRAKE STACKS (See Figure 10.1)

1. Place the Output Housing (#9) in a vertical position so that the key end of the Output Shaft (#1) is pointed down and the (4) Pins (#122) are pointed up. Make sure the Output Housing is on a flat and stable surface.

2. Install the **Brake Stack** onto the Output Shaft Spline, starting with a Drive Plate (#13) and then a Friction Disc (#12), ending with a Drive Plate (#13). There will be (4) Drive Plates (#13) and (3) Friction Discs (#12). (See Figure 9.15)

A Shim (#917) may be required for correct Stack Height. If so, it should be installed first on the (4) Pins (#122). (See Section 9-10)

Align the holes in the Drive Plates (#13) with the (4) Pins (#122) and align the internal teeth in the Friction Discs (#12) with the teeth on the Output Shaft Spline.

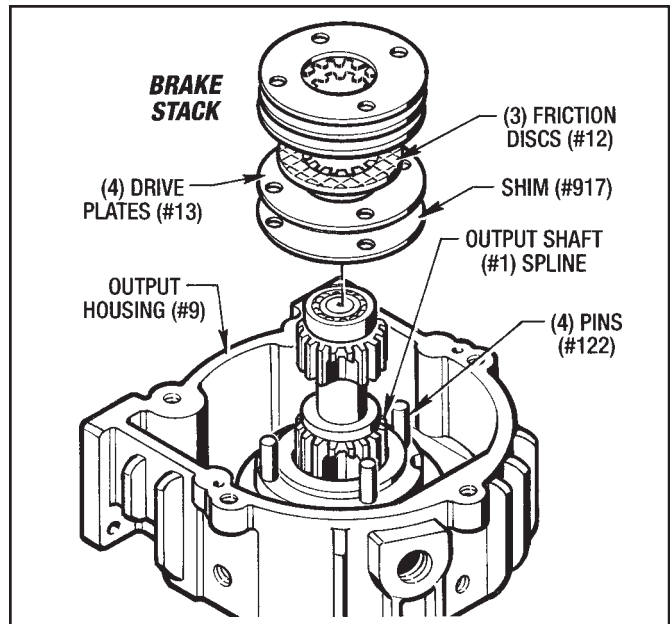

Figure 9.15 - Installing Brake Stack

3. Align one Gasket (#53) onto the Output Housing (#9) using the dowel pin holes for proper alignment. **Do not use any Gasket Sealant on this Gasket (#53).**

4. Lower the Piston Housing Sub-Assembly onto the Output Housing Sub-Assembly, aligning the internal spline teeth in the Thrust Plate (#5) with the spline teeth on the Output Shaft (#1).

With a mallet tap the Piston Housing until the (2) Dowel Pins (#68) engage the Output Housing. Check the Gasket (#53) to see if it is still properly aligned.

5. Install the **Clutch Stack** onto the Output Shaft Spline, starting with a Friction Disc (#12) then a Drive Plate (#13) and then another Friction Disc (#12). There will be (4) Drive Plates (#13) and (4) Friction Discs (#12). If required for correct Stack Height, place a shim (#917) last on the stack. (See Figure 9.16 and Section 9-10.)

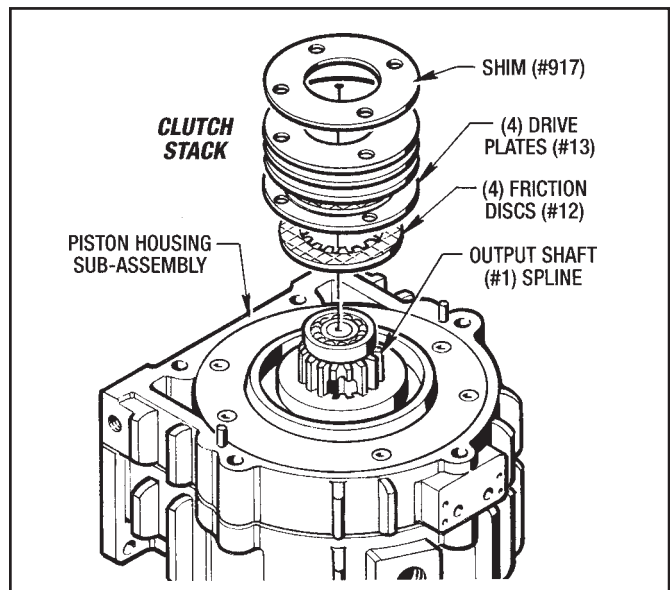

Figure 9.16 - Installing Clutch Stack

Align the holes in the Drive Plates (#13) with each other and align the internal teeth in the Friction Discs (#12) with the teeth on the Output Shaft Spline.

6. Position the Gasket (#53) on to the Piston Housing (#10) using the Dowel Pins (#68) for proper alignment. **Do not use any Gasket Sealant on this Gasket (#53).**
7. Lower the Input Housing Sub-Assembly onto the Piston Housing, aligning the (4) Driver Pins (#121) on the Input Shaft (#2) with the holes in the Drive Plates (#13) and the Shim (#917). Also make sure that the Pilot Bearing (#28) on the Output Shaft (#1) is properly seated in the Input Shaft (#2).
Tap the Input Housing (#8) with a mallet until the Dowel Pins (#68) engage the Input Housing. Check the Gasket (#53) to see if it is still properly aligned.
8. Use (5) Screws (#69) and (5) Lock Washers (#127) to attach the Input Housing, Piston Housing and Output Housing together. **Torque to 14 Ft. Lbs.**
9. If your Drive Unit had a Male Input Shaft and is not equipped with Fan Cooling, then replace the Key (#180) into the Input Shaft.

This completes the Reassembly Procedure for the Major Sub-assemblies. Before proceeding any further, an **OPERATIONAL CHECK** of the Clutch and Brake Movement should be made as described in **Section 5 - OPERATIONAL CHECKS.**

9-12 FAN AND FAN SHROUD INSTALLATION

(See Figure 10.1)

1. Install Key (#37) on the Input Shaft (#2).
2. Place Fan (#25) on the Input Shaft and tighten Set Screw (#70).
3. Place the Fan Shroud (#24) into place and attach with (2) Screws (#66) from the front of the Shroud.
4. Install Key (#180) into the Input Shaft.

9-13 ATTACHING C-FACE FLANGE AND DRIVE MOTOR (See Figure 10.2)

1. Attach the C-Face Flange (#200) to the Input Housing (#8) with (6) Screws (#201) and (6) Lockwashers (#202).
2. Attach an appropriate soft sling or lifting hook to the Drive Motor, and, with care, slide the motor shaft into the Quill Input Shaft, making sure the key in the motor shaft aligns with the keyway in the Input Shaft.

CAUTION - Be very careful not to bump the Input Shaft. This could damage the Bearings and the lip of the Oil Seals.

2. Attach the Drive Motor with (4) Mounting Screws and (4) Lock Washers. **NOTE:** These screws and washers are customer furnished.

9-14 INSTALLING BELT DRIVEN SHEAVE OR PULLEY (Male Input Shaft Only)

1. Install Guard Back Plate if necessary.
2. Assemble the Taper Lock Bushing and the Drive Sheaves or Pulley with the (2) Set Screws placed in the (2) Locking Holes.

3. Place assembled Drive Sheave or Pulley onto the Male Input Shaft as close as possible to the Drive Unit to minimize overhang shaft deflection. Tighten (2) Set Screws to lock it on the Input Shaft. (See Figure 9.17)

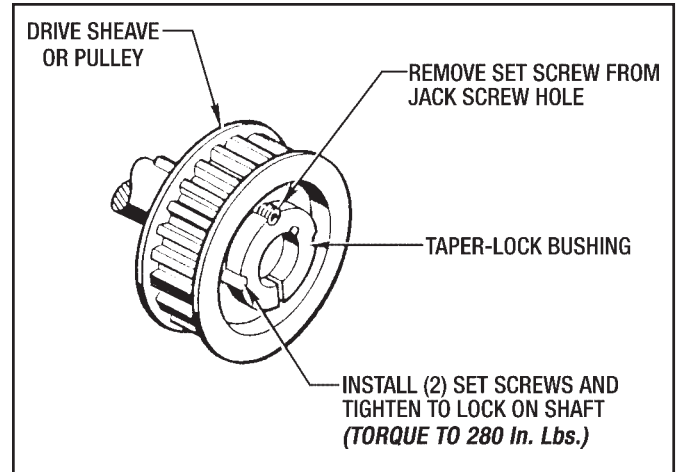

Figure 9.17 - Installing Drive Pulley

9-15 INSTALLING MANIFOLD MOUNTED CONTROL VALVE (See Figure 10.3)

1. Put the Gasket (#807) on the Piston Housing (#10). Use (Permatex #30) Gasket Sealant. **Make sure that no sealant gets into the pressure ports.**
2. Attach Manifold (#701) with (4) Screws (#727) and (4) Lock Washers (#737).
3. Attach the Control Valve (#700) to the Manifold (#701) with (2) Screws (#725). Align the pressure port in the control valve with the Locating Tube (#810) sticking up out of the Manifold (#701). **Also make sure that the (2) Seal Rings (#808) are in place under the Control Valve.**

9-16 FINAL REASSEMBLY

1. Replace all Pipe Plugs and Fittings removed for Inspection or Disassembly.
2. Fill the *Posidyne* Clutch/Brake Drive Unit with Mobil Automatic Transmission Fluid type ATF-210 type "F" or Mobil Multi-purpose Automatic Transmission Fluid, as indicated in **Section 4 - LUBRICATION.**

NOTE:

Other fluids may be specified for special applications. Always use the fluid specified on the Name Plate. **If there is any question concerning what fluid to use, contact Force Control Industries, Inc.**

3. Replace all external motor drive parts, safety guards, sheaves, pulleys, belts and couplings on belt drive units.
4. Before placing the Drive Unit back into service, completely check out the Operation as described in **Section 5 OPERATIONAL CHECKS.**

REASSEMBLY IS NOW COMPLETE AND THE DRIVE UNIT IS READY FOR SERVICE.

Section 10

ILLUSTRATED PARTS LIST

10-1 GENERAL INFORMATION

This section illustrates, lists and describes all available repair parts for the Force Control Size 02 *Posidyne* Clutch/Brake. Parts are identified on the exploded views with Part Reference Numbers. These Numbers correspond to the Part Reference Number given in the Parts List. The Part Name and Quantity Used is also given in the Parts List. This Part Reference Number, Part Name and Quantity should be used when ordering parts.

10-2 DRIVE MOTORS

The motors used with these Drive Units are standard and may be repaired or replaced by any qualified motor rebuild facility or supplier.

10-3 FACTORY REBUILD SERVICE

Reconditioning service is offered by Force Control Industries at the factory. Unless major parts (such as housing, shafts, piston, etc.) are damaged, the cost of complete factory rebuild will be 60% the cost of a new unit. Before returning a unit for this service, however, be sure to first contact the Force Control Industries Service Sales Department for authorization and shipping instructions. Force Control Industries cannot be responsible for units returned to the factory without prior notice and authorization.

Care must be given to the packing of return drives. Always protect mounting feet by attaching to a skid. Shipment-damaged drives always delay repairs. It is usually impossible to recover damage costs from the carrier. When possible describe the problem experienced on your shipping papers.

Return to: **Force Control Industries, Inc.**
3660 Dixie Highway
Fairfield (Hamilton), Ohio 45014
Telephone: 513-868-0900
Fax : 513-868-2105

10-4 ORDERING REPLACEMENT PARTS

When ordering replacement parts, please specify all of the following information:

1. **Drive Model Number** (on the nameplate)
2. **Drive Serial Number** (on the nameplate)
3. **Part Reference Number** (from the parts list or exploded view drawing.)
4. **Part Name** (from the parts list)
5. **Quantity** (from the parts list)
6. **Complete Shipping Information**

Failure to include information for items 1 thru 6 will only delay your parts order. Unless another method is specified for item 6, parts less than 150 pounds will be shipped United Parcel Service, parts over 150 pounds will be shipped Motor Freight. Air freight and other transportation services are available but only if specified on your order.

10-5 NAME PLATE AND MODEL NUMBERS

The Name Plate shown is located on the Piston Housing. See next page for Model Number Information.

Force Control Industries, Inc.	
Fairfield, Ohio	
<i>For Service / Parts Call</i>	
513-868-0900	
Posidyne® Clutch/Brake	
Model No.	<input style="width: 100%;" type="text"/>
Serial No.	<input style="width: 100%;" type="text"/>
Use Mobil® ATF 210	

Posidyne Model Numbers

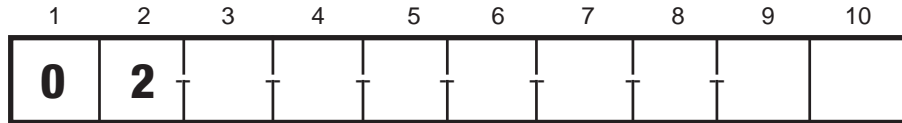

SIZE (1, 2)

0 2 = 02

INPUT (3)

- 1** = Basic
- 2** = 4-1/2" AK, 5/8" U, C-Face
- 3** = 4-1/2" AK, 7/8" U, C-Face
- 4** = 8-1/2" AK, 1-1/8" U, C-Face.
- 7** = Piggyback or Ceiling Mount.

FUNCTION (4)

- S** = Std.
- A** = A-Air Set Clutch, Medium Spring Set Brake.
- B** = B-Air Set Clutch, Heavy Spring Set Brake.
- C** = C-Air Set Clutch, No Brake.
- D** = SA-Air Set Clutch, Medium Spring Set Brake with Air Assist.

EXAMPLE:
02-1-D-1-H-1-Q-00
 Size 02 Posidyne Clutch/Brake with Basic Std. Male Input Shaft, SA Logic, Basic Output, Horizontal Mounting, Standard Cooling, Standard Stack Combination and Model Revision 00.

REVISION (9,10)
 (By Force Control)

STACK COMBINATION (8)

Q = Green Discs, 210 Fluid, Std. Plates.

COOLING (7)

- 1** = Std.
- 2** = Water.
- 5** = Fan.

MOUNTING POSITION (6)

- H** = Horizontal.
 - D** = VID - Vertical Input Down.
 - U** = VIU - Vertical Input Up.
 - L** = WML - Wall Mount Left.*
 - R** = WMR - Wall Mount Right.*
- * - Viewing Input Shaft

OUTPUT (5)

- 1** = Basic.
- 2** = 4-1/2" AK, 5/8" U, C-Face
- 3** = 4-1/2" AK, 7/8" U, C-Face
- 4** = 8-1/2" AK, 1-1/8" U, C-Face.

Repair Parts List - Figure 10.1
Size 02 Posidyne Clutch/Brake Assembly

REF. No.	PART NAME	QTY.	REF. No.	PART NAME	QTY.
1	Output Shaft	1	*43	Teflon Liner	
2	Input Shaft	1		O. D. Sealing (A, B and C Logic)	1
3	Piston	1		I.D. Sealing (S and SA Logic)	1
**5	Thrust Plate	1	**45	Breather	1
7	Bearing Retainer	1	**46	Sight Gauge	1
8	Input Housing	1	48	Heat Exchanger (With Water Cooling)	1
9	Output Housing	1	*51	Gasket	1
10	Piston Housing	1	*53	Gasket	2
11	Piston Retainer	1	63	Soc. Hd. Cap Screw, 5/16"-18 x 1-1/4" Lg.	4
*12	Friction Disc		66	Rd. Hd. Mach. Screw, 3/8"-16 x 1-1/2" Lg.	2
	A, B, S and SA Logic	7	68	Dowel Pin	2
	C Logic	4	69	Soc. Hd. Cap Screw, 5/16"-18 x 3-1/4" Lg.	5
*13	Drive Plate		70	Soc. Set Screw, #10-24 x 3/8" Lg.	2
	A, B, S and SA Logic	8	72	Pipe Plug, 1/2" NPT	1
	C Logic	4	73	Sq. Hd. Mag. Pipe Plug, 1/4" NPT	2
14	Pipe Plug, 1/2" NPT		74	Pipe Plug, 1/8" NPT (A, B and C Logic)	1
	Without Water Cooling	2	76	Soc. Hd. Cap Screw, 5/16"-18 x 1" Lg.	4
	With Water Cooling	1	89	Compression Fitting (With Water Cooling)	2
16	Bearing Retainer	1	121	Dowel Pin	4
24	Fan Shroud	1	122	Dowel Pin (Not on C Logic)	4
25	Fan	1	127	Lock Washer, 5/16"	13
*26	Ball Bearing	2	152	Self Tap. Screw, 5/16"-18 x 1/2" Lg.	4
*27	Ball Bearing	1	176	Anode (With Water Cooling)	1
*28	Ball Bearing	1	180	Key	1
*31	Oil Seal	2	181	Key	1
**34	Locknut	2	185	Access Cover	2
*36	Compression Spring		*195	Wear Sleeve	2
	A and C Logic	4	213	Pin	
	B and S Logic	8		A and C Logic	4
	SA Logic	24		B Logic	8
37	Key	1	218	Roll Pin	1
*39	O-Ring		237	Anti-Rotation Tag (With Water Cooling)	2
	A, B and C Logic	1	242	Pipe Tee (With Water Cooling)	1
	S and SA Logic	2	374	Low Hd. Soc. Screw, 1/4"-20 x 5/8" Lg.	6
*40	O-Ring	2	*917	Stack Shim	AR
*42	Teflon Liner				
	A, B and C Logic	1			
	S and SA Logic	2			

* Indicates parts in Minor Overhaul Kit.

** Indicates parts in Major Overhaul Kit. (This Major Overhaul Kit also includes all parts listed in the Minor Overhaul Kit.)

AR - As Required

Repair Parts List - Figure 10.2
Model 02 Posidyne Clutch/Brake
QUILL INPUT SHAFT AND MOUNTING ADAPTER FLANGES

REF. No.	PART NAME	QTY.	REF. No.	PART NAME	QTY.
2	Quill Input Shaft	1	180	Key	1
8	Input Housing, C-Face	1	200	Input C-Face Adapter	1
9	Output Housing, 4-1/2" Dia. AK	1	201	Soc. Hd. Cap Screw, 3/8"-16 x 1-1/4" Lg.	6
16	Bearing Retainer	1	202	Lock Washer, 3/8"	6
*26	Ball Bearing	1	203	Output Adapter Flange	1
*31	Oil Seal	1	204	Soc. Hd. Cap Screw, 3/8"-16 x 1-1/4" Lg.	4
**34	Locknut	1	205	Lock Washer, 3/8"	4
76	Soc. Hd. Cap Screw, 5/16"-18 x 1" Lg.	4	225	Lock Washer, 3/8"	2
121	Dowel Pin	4	226	Hex Hd. Screw, 3/8"-16 x 1-1/2" Lg.	2
127	Lock Washer	4			

* Indicates parts in Minor Overhaul Kit.

** Indicates parts in Major Overhaul Kit. (This Major Overhaul Kit also includes all parts listed in the Minor Overhaul Kit.)

QUILL INPUT SHAFT AND C-FACE ADAPTER FLANGE

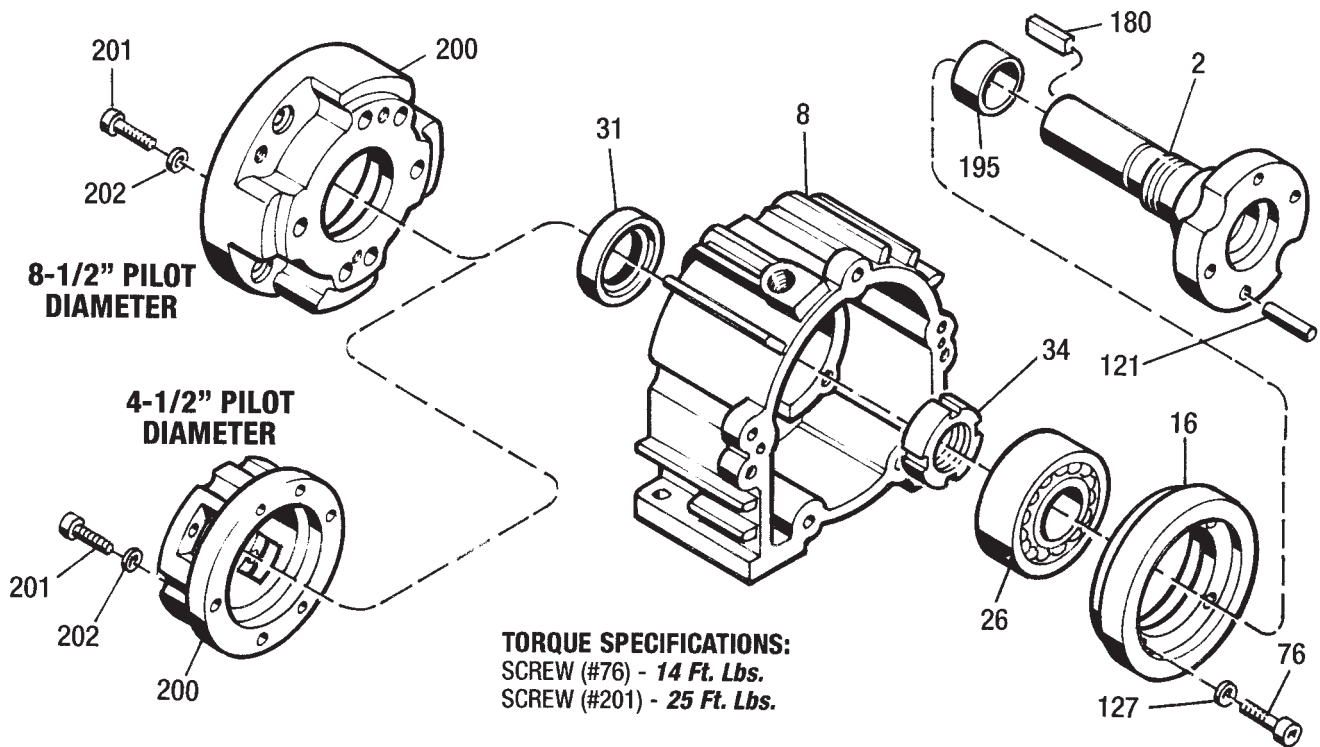

OUTPUT C-FACE ADAPTER AND D-FLANGE ADAPTER

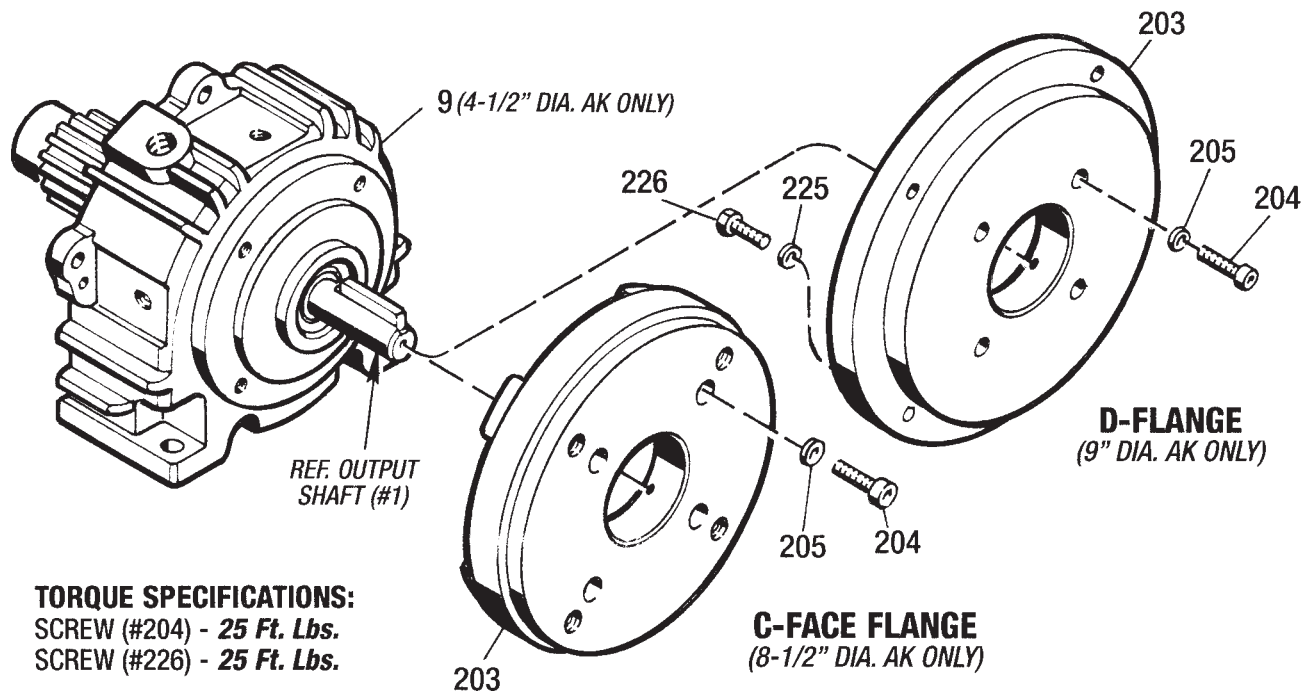

Figure 10.2 - Quill Input Shaft and Mounting Adapter Flanges

Repair Parts List - Figure 10.3
Model 02 Posidyne Clutch/Brake
MANIFOLD MOUNTED CONTROL VALVES

REF. No.	PART NAME	QTY.	REF. No.	PART NAME	QTY.
700	Manifold Mounted Control Valve	1	779	Muffler	1
701	Valve Manifold	1	*807	Manifold Gasket	1
725	Soc. Hd. Cap Screw	2	*808	O-Ring	2
727	Soc. Hd. Cap Screw	4	810	Locating Tube	1
737	Lock Washer	4	811	Threaded Insert	2
767	Pressure Gauge				
	1PC-3/8 Control Valve	1			
	2PC-3/8 Control Valve	2			

* - Indicates parts in Minor Overhaul Kit.

MANIFOLD MOUNTED CONTROL VALVES

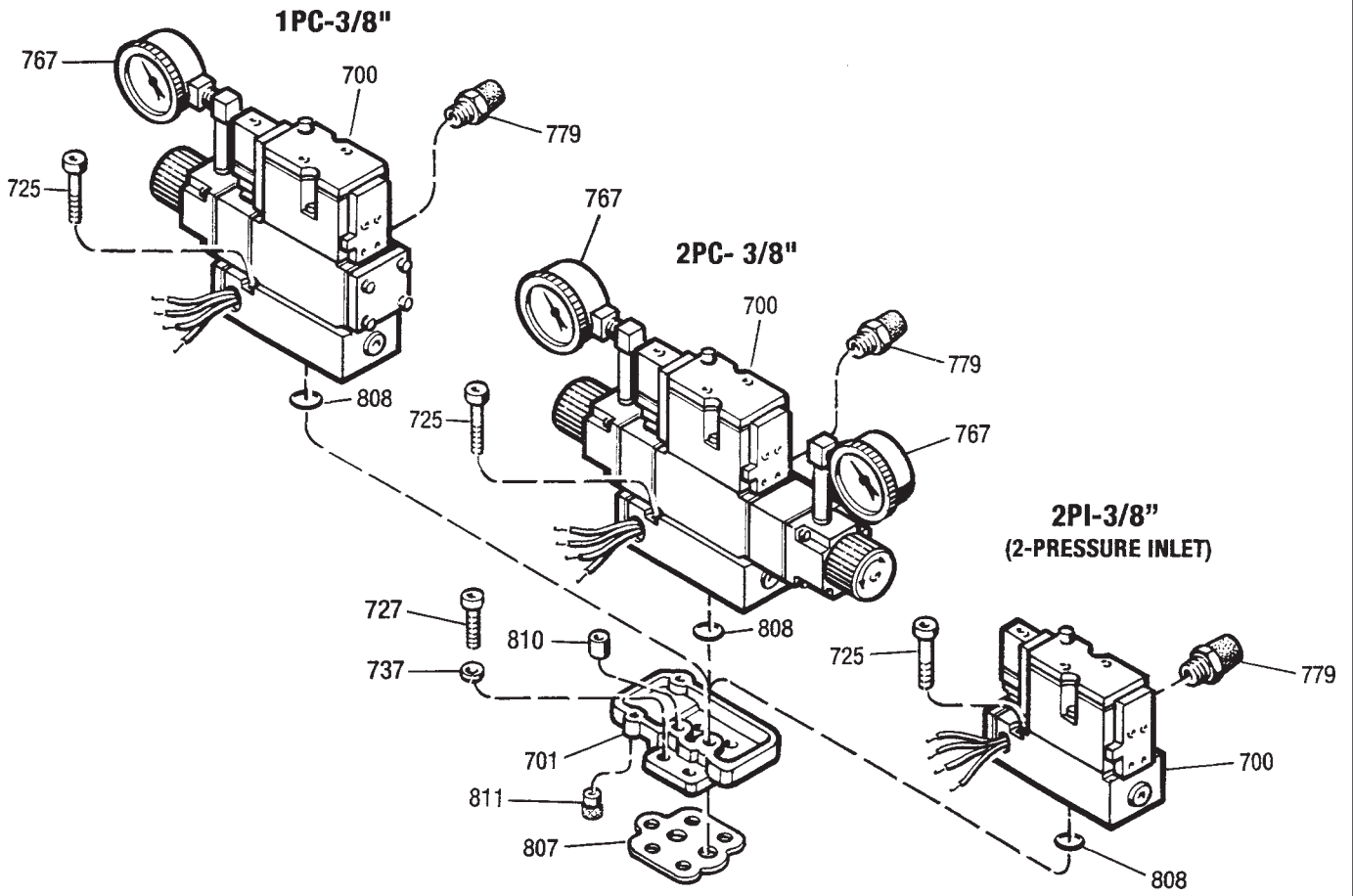

Figure 10.3 - Manifold Mounted Control Valves

FORCE CONTROL INDUSTRIES, Inc.

*Providing today's industries
with Oil Shear Clutch and
Brake Drives that deliver . . .*

- Flexibility • Efficiency*
- Endurance • Performance*
- and • Dependability.*

" Built to Last - Guaranteed to Perform "



FORCE CONTROL INDUSTRIES , INC.

MAIN OFFICE

P. O. Box 18366
Fairfield, Ohio 45018

3660 Dixie Highway
Fairfield, Ohio 45014

Tel: (513)868-0900

Fax: (513)868-2105

E-Mail: info@forcecontrol.com

Web Site: www.forcecontrol.com