

Section 12 PosiDrive Servo Systems

A Revolutionary Approach To Complex Servo Systems.



Servos made simple...

So simple that laptop computers are not required to make an adjustment to your motion profile. You no longer need to learn the complex, proprietary servo programming language.

An Industrial grade Touch Screen Interface (TSI) is preprogrammed and included with every *PosiDrive* servo system. Setup, motion control, and troubleshooting is greatly simplified. The TSI will record fault history, monitor motor performance, and display temperatures. It also lets you make any change to your motion profile. Even motor tuning is painless. Change your index speed, and adjust your accel/decels, all at the touch of a screen.

With the Force Control *PosiDrive* Servo System Solutions, you get a system that is complete, without hidden cost.

Don't be misled by others that will sell only individual components, and leave you to put together the pieces and struggle to get the system up and running.

With the *PosiDrive* Servo Systems, you get a package that is **plug and play**, ready to run out of the box, and is friendly to all users, not just servo factory-direct field service techs. With the optional 8.4" color TFT (Thin Film Transistor) Touch Screen Interface, you can run Multi-Axis Applications with just one display.

Take advantage of our application-engineering department. For decades, Force Control has been a leader in providing solutions for difficult indexing applications. Our engineers will meticulously review your specific application and properly select components that will perform up to your expectations. Our Goal is to provide you with a trouble free system with years of up-time performance. Our packages are pre-engineered and leave our plant ready to install with minimum start-up time. Also available from Force Control is our *PosiDrive* support team. We have experienced Programming Engineers and Controls Engineers that can be dispatched to your location for additional support.

PosiDrive Servo System Features and Benefits

Multi-Axis TSI TFT (Thin Film Transistor)

- ◆ Servos made simple.
- ◆ User friendly.
- ◆ Can run Multi-Axis Applications (Max. of 8) with one display.
- ◆ Painful proprietary software running on a PC/notebook is not necessary.
- ◆ Monitor key functions, fault history.
- ◆ Local control of servo motor.
- ◆ Motor tuning.
- ◆ Modify motion profile.
- ◆ Password protected.
- ◆ 8.4" Color Display
- ◆ Ethernet Ready
- ◆ Reliable Linux Operating System



Single-Axis TSI (Touch Screen Interface)

- ◆ Servos made simple.
- ◆ User friendly.
- ◆ Standard single axis applications preprogrammed.
- ◆ Painful proprietary software running on a PC/notebook is not necessary.
- ◆ Monitor key functions, fault history.
- ◆ Local control of servo motor.
- ◆ Motor tuning.
- ◆ Modify motion profile.
- ◆ Password protected.
- ◆ 6" Mono-color Display



PosiDrive Servo Motors

- ◆ Rugged industrial motors.
- ◆ Fractional through 20 HP (15kW).
- ◆ Brushless design.
- ◆ Efficient, low inertia.
- ◆ Neodymium iron boron magnets used for superior performance and low cogging.
- ◆ High frequency response.
- ◆ Motor feedback is resolver based for added ruggedness.
- ◆ Encapsulated windings for superior heat dissipation.
- ◆ Heavy duty cable connectors, rotatable, and water tight.



PosiDrive Amplifier

- ◆ 208-480 Volt AC three phase power.
- ◆ Integrated power supply.
- ◆ 3 to 70 amps, 200% peak.
- ◆ All digital design.
- ◆ Rugged metal design, ESD.
- ◆ Protection on short circuit, under/over voltage, over current, over temperature
- ◆ Built-in line filter.
- ◆ UL and CE.



PosiDrive Application

APPLICATION: Auto Catcher & Stacker (PosiDrive)

INDUSTRY: Asphalt Roofing Shingle Plants

PRODUCT: PosiDrive Servo System with UniMount Gearbox

WHERE THEY ARE USED: Shingles are manufactured by spreading colored granular material on one side of a wide web of paper or fiberglass saturated with hot asphalt. After the asphalt has cooled, the web is slit into three or four strips. Each strip is then notched and cut to length forming a finished shingle. Shingles are fed into a speed up conveyor to establish spacing between the ends of each shingle. Shingle Catchers, (also called Auto Catchers or Shingle Stackers), are used to catch and stack finished shingles into bundle size groups prepared for wrapping.

HOW THEY WORK: Shingle Catchers have two parallel shafts with blades located at 90 degrees along each shaft called “Star Wheels”. The inside blades of the star wheels are positioned to form a shelf for the finished shingles fed by a high-speed conveyor. When a pre-determined number of singles, usually ranging from three to seven, are caught on the inside horizontal blades, the star wheels are indexed 90 degrees allowing the group of shingles to drop into a collection chamber below. Precise, rapid indexing between the continuously fed shingles is required to prevent jams. The Star Wheels require precise accuracy to ensure the blade position is maintained. This is easily achieved using the UniMount Gearbox and the PosiDrive Servo System. After a full bundle is caught, the collection chamber is opened and the full bundle is dropped onto a conveyor, which takes the shingles to be wrapped.

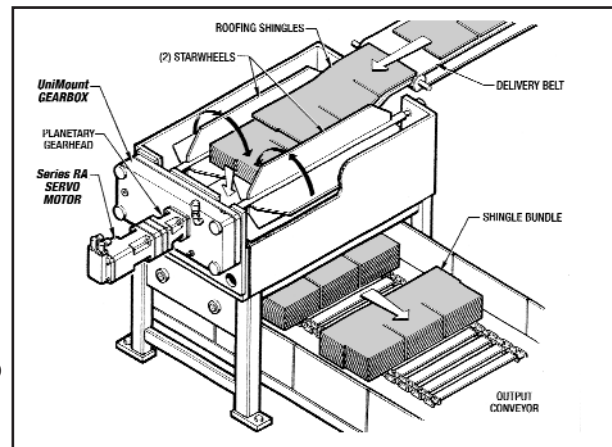

12

PROBLEMS SOLVED: The PosiDrive Servo System provides more consistent performance to minimize shingle jams and maximize machine output. There are very few mechanical components so there is little maintenance required.

IMPORTANT FEATURES:

- ◆ PosiDrive Servo Motor with low inertia and high torque provides maximum performance for this demanding application.
- ◆ PosiDrive Servo Control is prepackaged and pre-programmed for the customer. The control panel may have two or more PosiDrive Servo Amplifiers for multiple diverters, catchers, flippers, or stackers for a customized solution to the plant. Final system startup variables are input through the TSI (Touch Screen Interface). There is no complex programming language to learn.
- ◆ The TSI can be mounted in its own small enclosure near the catcher with the main amplifier control panel being remote on multi-axis systems. This saves space in the critical area near the catcher while providing operators the flexibility of having the TSI nearby for system operation and monitoring. The TSI can communicate with multiple (8) PosiDrive Servo Drives on multi-axis systems.