

WORLDWIDE LEADER IN OIL SHEAR TECHNOLOGY

POSITORQ

DYNAMOMETER LOAD BRAKES

FEATURING OIL SHEAR TECHNOLOGY

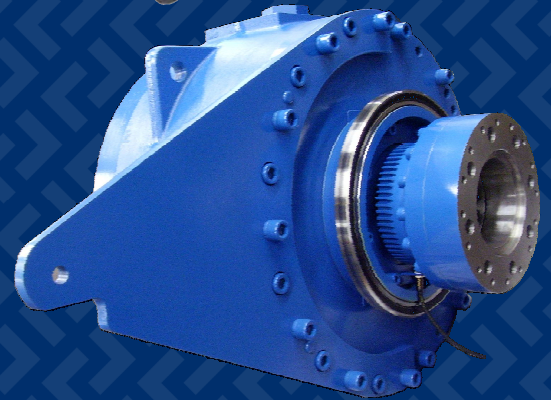
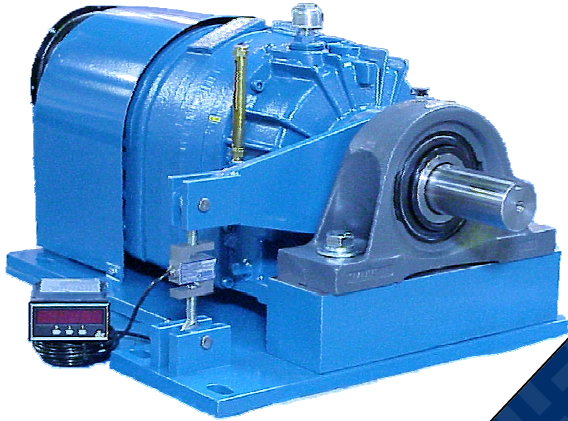

LOW SPEED-HIGH TORQUE LOAD TESTING
DYNOS FOR LARGE AND SMALL MACHINES

MADE IN THE USA



FORCECONTROL.COM

OIL SHEAR TECHNOLOGY

The Positorq load brakes with Oil Shear Technology are of a hydroviscous design. The film of transmission fluid transmits torque between the drive plates and friction discs. Specially formulated transmission fluid is used for cooling and provides a hydroviscous fluid film between the friction surfaces during the dynamic, or slipping phase of engagement.

The transmission fluid in shear transmits torque between the two components. This provides a smooth torque (down to 0 RPM) that is controlled by the pressure on the friction stack through a proportional regulator or servo valve. Actuation can be pneumatic or hydraulic.

An external Forced Lube Cooling Unit circulates the fluid through the brake friction stack and back to the FLCU to be cooled, filtered, and returned to the brake. This allows for continuous operation at full torque and hp.

Oil-to-water or oil-to-air heat exchangers provide the proper cooling needed.

This system provides smooth controllable torque quiet enough for noise testing, and nearly unlimited life

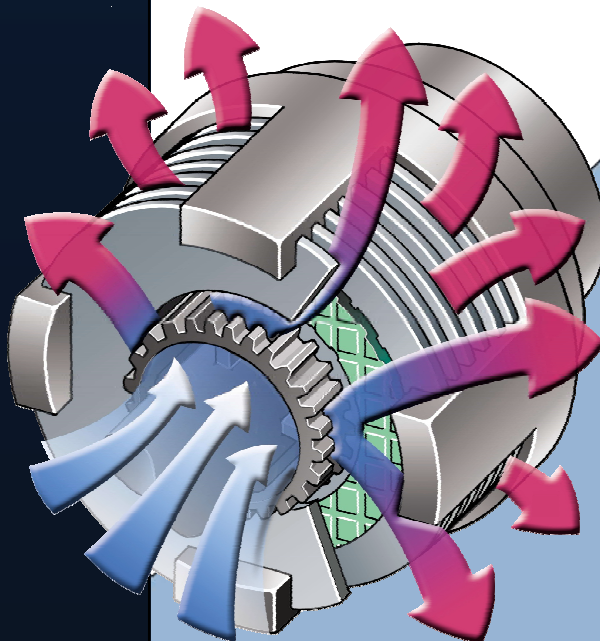

WHERE TO USE POSITORQ DYNAMOMETER LOAD BRAKES

APPLICATIONS

- Transmissions
- Final Drives
- Axle Components
- Gear Reducers
- Drive Shafts
- Steering Gear
- Linear and Rotary Actuators
- Belt and Chain Drives



FOR TESTING OF

- Tractors & Agricultural
- Dozers and graders
- Trucks
- Helicopter transmissions
- Snow mobiles, ATV's
- Underground Auger Machines
- Cement Finishing Machines
- Rail Track Repair Equipment
- Underground Mining Equipment
- Road Construction Machines
- Lawn & Garden Machines
- Military Equipment
- High Capacity Torque Wrenches

OIL SHEAR BENEFITS

- Quick Response—The new high speed piston design for exceptional response with near zero hysteresis.
- Proportional Linear Torque Control—Torque proportional to actuation pressure.
- Unlimited continuous High Torque at Low Speed
- High Static Torque—High spike torque up to 3 times continuous torque.
- Smooth full load torque with no stick slip, chatter, or cogging down to zero RPM.
- Quiet—Great for noise testing transmissions or other gear drive, chain, or belt drives.
- Compact design allows direct mounting including direct axle mount for many low speed applications.
- Air or Hydraulic Actuation
- Extremely Long Service Life—Due to Oil Shear Technology maintenance is nearly non-existent.
- Systems available from 10 to 300,000 Lb. Ft. of torque and up to 3000 hp.

POSITORQ Dynamometer Load Brakes

**TB-11 Tandem Stack
Positorq Dyno Load Brake**

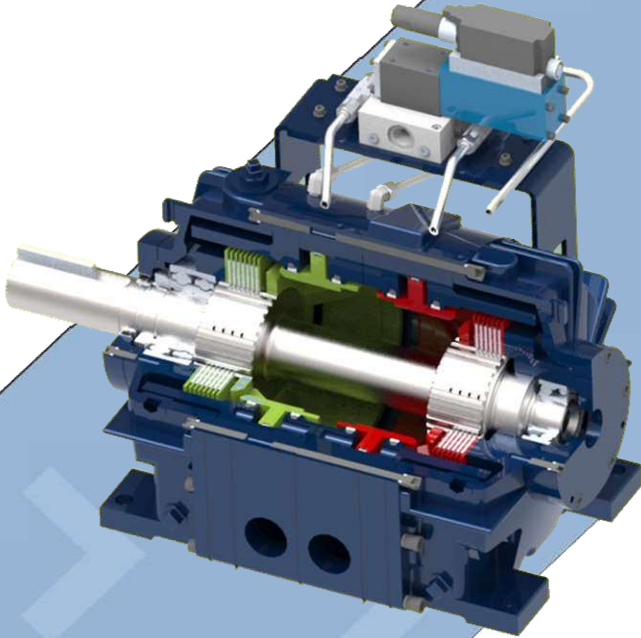

**Forced Lube Cooling and
Actuation Unit**

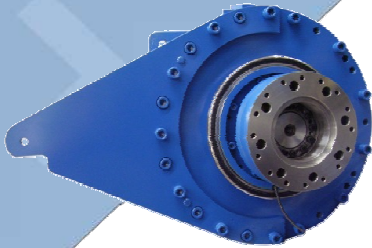
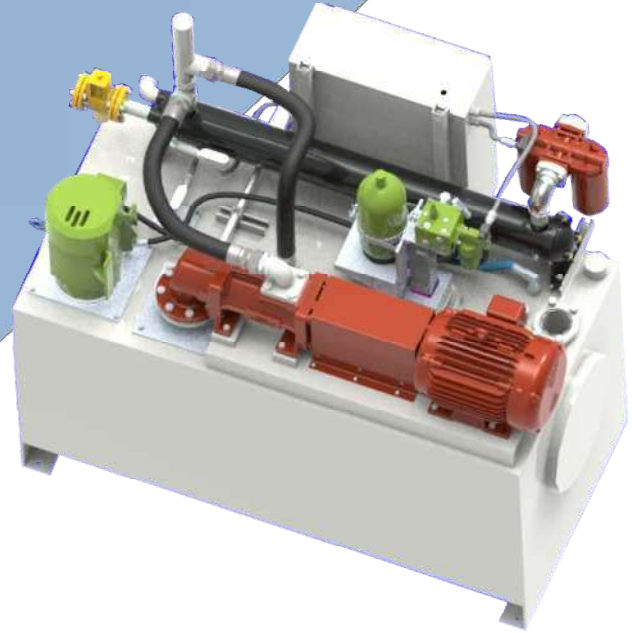

TB-85 Positorq Load Brake direct flange mounted to the axle hub with a single torque arm.

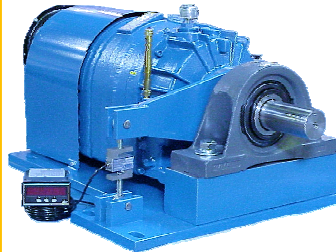

TB-20 Positorq Load Brake package with brake mounted in bearings, torque arm and load cell, all mounted on a rigid base.



TB-83 Positorq Load Brake complete with torque arm, load cell, all mounted on a fluid reservoir with heat exchangers, and actuation system



TB-20 Positorq Load Brake used to test a hydraulically operated large engine starter motor. Testing was designed for 24 hr continuous testing.

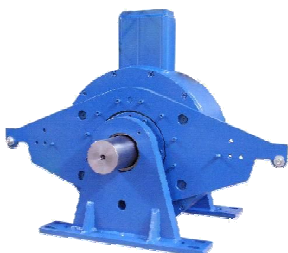

TB-83 Positorq Dynamometer Load Brake with dual torque arms for better torque data.

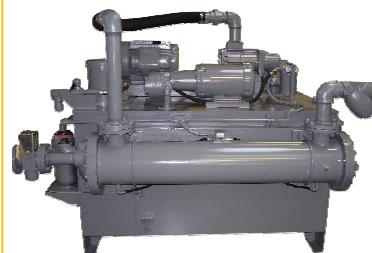

Typical Forced Lube Cooling Unit with Oil-to-water heat exchangers cooling fluid and actuation pumps, filters, mounted on a free standing reservoir.

POSITORQ OIL SHEAR DYNAMOMETERS



WORLD WIDE LEADER IN OIL SHEAR TECHNOLOGY

MORE AT FORCECONTROL.COM

Force Control Industries, Inc.
3660 Dixie Hwy. Fairfield, OHIO 45014 USA
Phone: 513-868-0900 Fax: 513-868-2105
info@forcecontrol.com Web: www.forcecontrol.com
Cat.# Dyno 1219 200