

APPLICATION BULLETIN



APPLICATION: Plastic Cutting Shear

INDUSTRY: Plastic Sheeting Industry

PRODUCT: Oil Shear X4-5P5 *Posidyne* Clutch/Brake

PLASTIC CUTTING SHEAR

RETROFIT

WITH DRY FRICTION CLUTCH/BRAKE

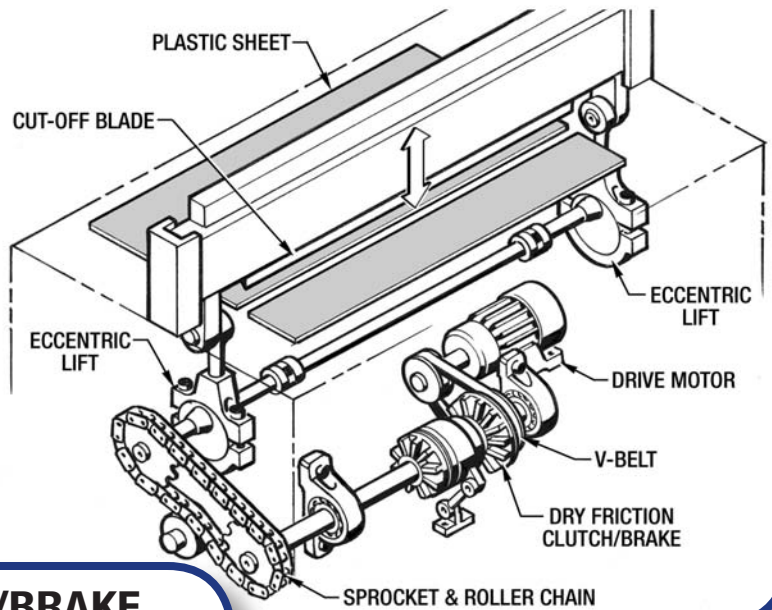

Posidyne X4-5P5 CLUTCH/BRAKE

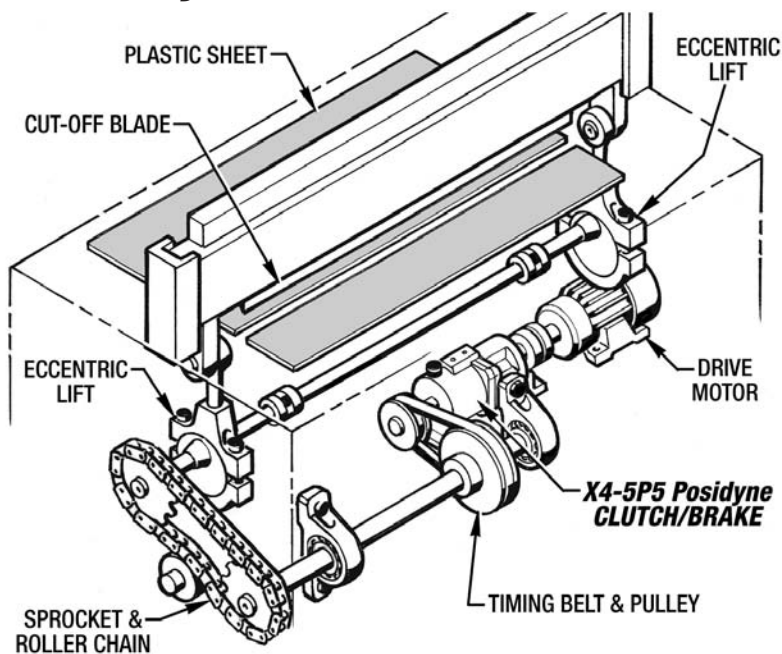

PLASTIC CUTTING SHEAR

WHERE THEY ARE USED:

Used to retrofit the original equipment dry friction clutch/brake on plastic sheet cutting shears.

HOW THEY WORK:

Plastic is extruded into sheets of varying sizes and thicknesses. These sheets are cut to particular lengths depending on customer needs. A single revolution of the cam and driveshaft assembly pulls down the cutting blade while the motor runs continuously.

PROBLEMS SOLVED:

The dry friction clutch/brake would break down under high cycle cutting and would have to be rebuilt about every two to three weeks, resulting in a total cost of over **\$57,000** for repair parts only. The jackshaft, bearing blocks and roller chain would all have to be removed from the Cutting Shear to change the dry friction unit. This fact, combined with the frequent repairs would cause considerable down time and lost production time. Significant additional savings are realized through the reduction of this repair time and any lost production time.

IMPORTANT FEATURES:

- **Oil Shear** technology offers accurate and repeatable positioning.
- Totally enclosed, sealed design eliminates problems associated with dust and dirt.
- Adjustable acceleration and deceleration rate allows maximum start and stop without damaging mechanical components.
- Higher cycle rate provides more shearing options.
- Foot mounting means simple installation and removal of the *Posidyne* Clutch/Brake.



FORCE CONTROL INDUSTRIES, INC.

3660 Dixie Highway Fairfield, Ohio 45014
Phone: 513-868-0900 Fax: 513-868-2105
E-Mail: info@forcecontrol.com Web: www.forcecontrol.com